

Haverford Township - Board of Commissioners

Meeting: Monday, February 05, 2024

Time: 7:00 p.m.

Location: Commissioners Meeting Room -1014 Darby Rd., Havertown PA, 19083

Work Session Meeting

Presentations:

2023 pension performance presentation by Sarah Hart, PFM Asset Management, Mike Glackin, CIBZ InR Advisors and Jim Kennedy, Thomas J. Anderson Associates

Parks and Recreation – Parks, Recreation and Open Space (Pros) Plan – Herbert, Rowland & Grubic, Inc.

Police Department – Update

Commissioner Committee Updates

Next Week:

- Ordinance No. P1-2024: Recycling – Community Events (2nd Reading)

Ordinance No. P2-2024: Traffic (2nd Reading)

- Ordinance No. P3-2024: Skatium – Café Lease Renewal (1st Reading)

Ordinance No. P4-2024: Traffic (1st Reading)

- Resolution No. 2360-2024: Subdivision/Land Development – 14 Claremont Blvd.

- Resolution No. 2362-2024: ARPA – Police Department – 2024 4 x 4 Electric ATV

- Resolution No. 2363-2024: Library-Request for Funding under the Commonwealth of Pennsylvania, Department of Community and Economic Development, COVID-19 ARPA Capital Projects Fund Multi-Purpose Community Facilities Program

Resolution No. 2364-2024: Skatium Locker Rooms - Request for Funding under the Commonwealth of Pennsylvania, Department of Community and Economic Development, COVID-19 ARPA Capital Projects Fund Multi-Purpose Community Facilities Program

- Resolution No. 2365-2024: ARPA – Public Works Department – Heavy Duty Equipment

- Resolution No. 2366-2024: Announcement of Public Hearing- Zoning – Amending Chapter 47 entitled Amusement Devices and Chapter 182 Entitled Zoning

- Resolution No. 2367-2024: Preliminary/Final Plan – 2224-2228 Haverford Road

Approval of Chief of Police contract extension
Approval of Parks, Recreation & Open Space Plan

Purchases:

Police Department :

2 2024 Electric Chevrolet Trail Blazers,
3 2024 Chevrolet Tahoe Police Vehicles and
1 2024 4 x 4 Electric ATV

Public Works :

General Operating and Capital Projects Purchases
2024 F350 Regular Cab with 9ft. Western Pro Plus Plow
2024 F350 Super Cab with 9ft. Western Pro Plus Plow
2024 Altec 75ft. Tree Bucket Truck on International Cab & Chassis
2024 HV607 International Cab & Chassis for Recycling Truck
2024 20 YD Recycling Body for Cab & Chassis
1 Pole Barn for Public Works Yard, with Concrete Pad

ARPA Purchases:

One (1) 2024 F650 Cab and Chassis with multi lift hook system with attachments including a Stainless Steel Body with Salt Spreader and 9 ft. Western Pro Plus Plow
One (1) Two Ton Falcon Asphalt Recycle Body
One (1) 2024 Caterpillar 938 Front End Loader
One (1) 2024 Broom Bear Sweeper on International Cab and Chassis
One (1) 2024 Brush Bandit 18 Inch Tipper with Winch Three (3) SaltDogg Pro1500 Electric Poly Three (3) Hopper Spreaders with Auger

Contracts:

The Skatium - Amend contract award to Elliott-Lewis Corp, Philadelphia, PA for the chiller replacement project and Amend contract award to AJM Electric, Chester Township, PA for electrical work related to the chiller replacement project

Appointments:

Finance Department Special Counsel appoint Jennifer W. Brown, Esq of Eastburn & Gray, PC, Blue Bell, PA to serve as Township Act 511 Special Counsel.

Bryn Mawr Playfield Association

Civil Service Alternate

The Grange

6th Ward Only – Senior Citizen Appointment

Vacancy Committee

Vacant Property Review Committee

Proclamation – Ed Magargee Delaware County Chapter of the Pennsylvania Society of Professional Engineers 2024 Lifetime Achievement Award

Black History Month

Haverford Township - Board of Commissioners

Meeting: Monday, February 12, 2024

Time: 7:00 p.m.

Location: Commissioners Meeting Room -1014 Darby Rd., Havertown PA, 19083

Regular Meeting Agenda

1. Opening of Meeting

Roll Call

Pledge of Allegiance

Announcement: The Board met in Executive Session prior to the Work Session last week to discuss Legal and Real Estate matters

2. Proclamations

Delaware County Chapter of the Pennsylvania Society of Professional Engineers 2024 Lifetime Achievement Award - Ed Magargee

Recognizing and Celebrating Black History Month

3. Citizens Forum – 20 Minutes – Registered Speakers – 20 Minutes – Agenda Items

4. Bureau of Fire Update

5. Township Auditor Update

6. Township Manager Update

7. Approval of Minutes

Motion: to approve the Reorganization Meeting Minutes of January 2, 2024 and the Regular Meeting Minutes of January 8, 2024.

8. Approval of Warrants

General Fund Disbursements in the amount of \$2,022,441.19

Sewer Fund Disbursements in the amount of \$214,974.93

Community Development Block Grant Fund Disbursements in the amount of \$44,344.81

Capital Projects Fund Disbursements in the amount of \$683,742.25

American Rescue Plan Fund in the amount of \$83,265.05

General & Sewer Fund Payroll for January 18, 2024 in the amount of \$921,992.76

General & Sewer Fund Payroll for February 1, 2024 in the amount of \$786,748.37

Credit Card Statement Ending January 27, 2024 in the amount of \$12,833.49

9. Appointment of Special Counsel

Motion to appoint Jennifer W. Brown, Esq. of Eastburn & Gray, PC, Blue Bell, PA to serve as Township Act 511 Special Counsel for any matters related to the enforcement and administration of business privilege, mercantile and local services tax at a rate of \$250 per hour; on an as needed basis.

10. Ordinance No. P1-2024

Amending Chapter 95 – Recycling (2nd Reading)

Motion: to adopt the second reading of Ordinance No. P1-2024 amending and supplementing the General Laws of the Township of Haverford Chapter 95, Article III Recycling, Sections 95-23 and 95-25 by adding a definition of Community Event and requiring organizers to provide separate containers for and to collect recyclable materials.

11. Ordinance No. P2-2024

Traffic (2nd Reading)

Motion: to adopt the second reading of Ordinance No. P2-2024 establishing/rescinding traffic restrictions on the following highways:

Parking Time Limited:

Establish: On the west side of Allston Road from Brookline Boulevard to, but not including 1204 Allston Road, 15-minute parking from 8:00 a.m. to 4:00 p.m., Monday through Friday

Rescind: Parking of All Vehicles Prohibited at All Times:

East side of Allston Road from Brookline Boulevard to Sagamore

West side of Allston Road from Brookline Boulevard to a point 35 feet south thereof

Rescind: Special Purpose Parking Zones:

On the West side of Allston Road, approximately 75 feet south of its intersection with Brookline Boulevard

12. Ordinance No. P3-2024

Skatium – Café Lease Renewal (1st Reading)

Motion: to adopt the first reading of Ordinance P3-2024 authorizing a renewal lease agreement with Shef & Sons, LLC dba Hav-A-Burger, Essington, PA for a portion of certain property located at 1018 Darby Road (the Skatium), Havertown, PA subject to review by the Township Solicitor and further subject to the approval of the Township Manager of the final document.

13. Ordinance No. P4-2024
Traffic (1st Reading)

Motion: to adopt the first reading of Ordinance No. P4-2024 authorizing traffic restrictions on the following highways:

Establish: Special Purpose Parking Zones: In front of 2447 Wynnefield Drive

Establish: Parking of All Vehicles Prohibited at All Times: No Parking Here to Corner - the unit block of Colfax Road, north side, from the corner of Darby Road to a point 60 feet west.

Rescind: Permit Parking Only on Mifflin Avenue

14. Resolution No. 2360-2024
Subdivision/Land Development – 14 Claremont Blvd.

Motion: to adopt Resolution No. 2360-2024 approving the recommendations and findings of the Planning Commission are hereby adopted and the Preliminary / Final / Land Development Plan for Caramanico Homes, LLC, 14 Claremont Blvd., Haverford Township, Delaware County, dated November 30, 2023, is approved subject to compliance with the recommendations described hereinabove.

15. Resolution No. 2362-2024
Use of ARPA Funds - Police Department

Motion: to adopt Resolution No. 2362-2024 approving the use of funds from the Township's American Rescue Plan Fund allocation for the purchase of one (1) 2024 Landmaster AMP crew 4 x 4 electric ATV for a total of \$22,800.01.

16. Resolution No. 2363-2024
Grant Application - Library Construction

Motion: to adopt Resolution No. 2363-2024 approving that the Board of Commissioners of the Township of Haverford of Delaware County hereby acknowledges its support for an application to the Commonwealth of Pennsylvania, Department of Community and Economic Development, COVID-19 ARPA Capital Projects Fund Multi-Purpose Community Facilities Program in the amount of \$268,750 to assist with the construction and technology outfitting of the Maker's Space/Innovation Zone to be located within the newly renovated Haverford Township Free Library and that the Applicant does hereby designate David R. Burman, Township Manager and Aimee M Cuthbertson, Assistant Township Manager as the officials to execute all documents and agreements between the Township of Haverford and the Department of Community and Economic Development to facilitate and assist in obtaining the requested grant.

17. Resolution No. 2364-2024
Grant Application - Skatium Locker Rooms

Motion: to adopt Resolution No. 2364-2024 approving that the Board of Commissioners of the Township of Haverford of Delaware County hereby acknowledges its support for an application to the Commonwealth of Pennsylvania, Department of Community and Economic Development, COVID-019 ARPA Capital Projects Fund Multi-Purpose Community Facilities Program in the amount of \$500,000 to assist with the space planning, construction and renovation of the locker rooms and related space at the Haverford Township Skatium; and, designating David R. Burman, Township Manager and Aimee M Cuthbertson, Assistant Township Manager as the officials to execute all documents and agreements between the Township of Haverford and the Department of Community and Economic Development to facilitate and assist in obtaining the requested grant.

18. Resolution No. 2365-2024
Use of ARPA Funds – Public Works Heavy Equipment

Motion: to adopt Resolution No. 2365-2024 that the Board of Commissioners of the Township of Haverford desires to make improvements and financial investments in several Township projects and initiatives in accordance with the allowable spending structure as described by the U.S. Department of Treasury's Final Rule, as follows:

One (1) 2024 F600 Chassis 4x4 SD Regular Cab 145" WB DRW XL (F6L) in an amount not to exceed \$63,335.00 under CoStars Contract #025-E22-381 Fred Beans Ford of Mechanicsburg 6320 Carlisle Pike Mechanicsburg, Pennsylvania 17050

For Chassis listed above:

One (1) Multi-Lift XR5S-3050 Hook Lift 12,000 Capacity

One (1) 10' Stainless Steel Dump Body

One (1) 20 Gallon Stainless Steel Valve/Tank Combo

One (1) Stainless Steel Salt Spreader with Poly Spinner

in an amount not to exceed \$89,500.00 under CoStars Contract #025-E22-432 Stephenson Equipment, INC. 4210 Chambers Hill Rd. Harrisburg, PA 17111

One (1) 11' Steel Flat Bed with Side Pockets Mounted in an amount not to exceed \$18,500.00 under CoStars Contract #025-E22-432 Stephenson Equipment, INC. 4210 Chambers Hill Rd. Harrisburg, PA 17111

One (1) Western 9' Pro Plus Snow Plow in an amount not to exceed \$8,000.00 under CoStars Contract# 025-E22-432 Stephenson Equipment, INC. 4210 Chambers Hill Rd. Harrisburg, PA 17111

One (1) 2-Ton Falcon Asphalt Recycler & Hot Box Hook Lift in an amount not to exceed \$40,911.20 under CoStars Contract# 025-E22-432 Stephenson Equipment, INC. 4210 Chambers Hill Rd. Harrisburg, PA 17111

One (1) 2024 Caterpillar 938 Front End Loader in an amount not to exceed \$281,165.00 under CoStars Contract #4400011420 Folly Cat INC. 855 Centennial Ave. Piscataway, NJ 08855

One (1) 2024 Broom Bear Sweeper on International Cab and Chassis in an amount not to exceed \$407,000.00 under CoStars Contract #025-E22-471 GranTurk Equipment Co., INC. 1

One (1) 2024 Brush Bandit 18 Inch Chipper with Winch in an amount not to exceed \$98,715.00 under CoStars Contract #4400028339 SEI Stephenson Equipment, INC. 4210 Chambers Hill Rd. Harrisburg, PA 17111

Three (3) SaltDogg Pro1500 Electric Poly Hopper Spreaders with Auger in an amount not to exceed \$14,000.00 under CoStars Contract #4400028339 SEI Stephenson Equipment, INC. 4210 Chambers Hill Rd. Harrisburg, PA 17111

19. Resolution No. 2366-2024
Announcement of Public Hearing- Zoning – Amending Chapter 47 entitled Amusement Devices

Motion: to adopt Resolution No. 2366-2024 amending Chapter 47 entitled Amusement Devices Holding a Public Hearing on March 4, 2024 at 6:30 p.m. in the Commissioners Meeting Room, 1014 Darby Road, Havertown, PA.

20. Resolution No. 2367-2024
Preliminary/Final Plan – 2224-2228 Haverford Road

Motion: to consider Resolution No. 2367-2024.

21. Approval:

Motion: to approve Chief of Police contract extension retroactively from 1/4/2024 to 1/4/2026.

Motion: to approve the Park, Recreation & Open Space Plan

22. Purchases:

Police Department

Motion: to authorize the purchase of three (3) 2024 Chevrolet Tahoe Police Vehicles and two (2) 2024 Electric Chevrolet Blazer Police Vehicles 1MF26, under CoStars Contract #013-E22-264, from Whitmoyer Auto Group, 1001 East Main Street, Mount Joy, PA, in the amount of \$278,800.

Motion: to authorize the purchase of one (1) 2024 Landmaster AMP Crew 4 x 4 from Wide World West Chester, PA in the amount of \$22,800.01

Public Works Department from the General Operating and Capital Project Budgets

Motion to authorize the purchase of:

2024 Ford F350 Regular Cab with 9ft Western Pro Plus Plow in the amount of \$66,110.00 under CoStars Contract #025-E22-387 from Hondru Ford, Manheim, PA

2024 Ford F350 Super Cab with 9ft Western Pro Plus Plow in the amount of \$70,060.00 under CoStars Contract #025-E22-387 from Hondru Ford, Manheim, PA

2024 Altec 75ft Tree Bucket Truck with International Cab & Chassis in the amount of \$299,000.00 under CoStars Contract #4400019945 from Altec, Inc, Plains, PA

2024 International Cab & Chassis HV607 for Recycling Truck in the amount of \$128,164.40 under CoStars Contract #025-E22-471 from GranTurk Equipment Co. Inc, Bridgeport, PA

2024 Recycling Body (20-yard) for Cab & Chassis noted above in the amount of \$108,373.00 under CoStars Contract #025-E23-577 from Ascendence Trucks, Swedesboro, NJ

Pole Barn (1) with Concrete Pad in the amount of \$50,000.00 CoStars Contract #008-E23-1096 from Shirk Pole Buildings LLC, East Earl, PA

Public Works Department from ARPA Funds

Motion to authorize the purchase of:

One (1) 2024 F600 Chassis 4x4 SD Regular Cab 145" WB DRW XL (F6L) in an amount not to exceed \$63,335.00 under CoStars Contract #025-E22-381 from Fred Beans Ford of Mechanicsburg 6320 Carlisle Pike Mechanicsburg, Pennsylvania 17050

For Chassis listed above:

One (1) Multi-Lift XR5S-3050 Hook Lift 12,000 Capacity

One (1) 10' Stainless Steel Dump Body

One (1) 20 Gallon Stainless Steel Valve/Tank Combo

One (1) Stainless Steel Salt Spreader with Poly Spinner

in an amount not to exceed \$89,500.00 under CoStars Contract #025-E22-432 from Stephenson Equipment, INC. 4210 Chambers Hill Rd. Harrisburg, PA 17111

One (1) 11' Steel Flat Bed with Side Pockets Mounted in an amount not to exceed \$18,500.00 under CoStars Contract #025-E22-432 from Stephenson Equipment, INC. 4210 Chambers Hill Rd. Harrisburg, PA 17111

One (1) Western 9' Pro Plus Snow Plow in an amount not to exceed \$8,000.00 under CoStars Contract# 025-E22-432 from Stephenson Equipment, INC. 4210 Chambers Hill Rd. Harrisburg, PA 17111

One (1) 2-Ton Falcon Asphalt Recycler & Hot Box Hook Lift in an amount not to exceed \$40,911.20 under CoStars Contract# 025-E22-432 Stephenson Equipment, INC. 4210 Chambers Hill Rd. Harrisburg, PA 17111

One (1) 2024 Caterpillar 938 Front End Loader in an amount not to exceed \$281,165.00 under CoStars Contract #4400011420 from Folly Cat INC. 855 Centennial Ave. Piscataway, NJ 08855

One (1) 2024 Broom Bear Sweeper on International Cab and Chassis in an amount not to exceed \$407,000.00 under CoStars Contract #025-E22-471 from GranTurk Equipment Co., INC. 1 Schuylkill Parkway, Bldg. B, Bridgeport, PA 19405

23. Appointments:

Representative to Bryn Mawr Playfield Association - Motion: to appoint (*space for name to be filled in after voting is completed*) to the Bryn Mawr Playfield Association.

Civil Service Commission - Alternate - Motion: to appoint (*space for name to be filled in after voting is completed*) to fill an unexpired six (6) year term to expire December 31, 2028.

Friends of the Grange - Motion: to appoint (*space for name to be filled in after voting is completed*) to fill an unexpired two (2) year term to expire December 31, 2024.

Senior Citizen Advisory Board - 6th Ward Only

Vacancy Committee - Motion: to appoint (*space for name to be filled in after voting is completed*) to serve on the Vacancy Committee for a one-year term to expire December 31, 2024.

Vacant Property Review Committee - Motion: to appoint (*space for name to be filled in after voting is completed*) to serve on the Vacant Property Review Committee for a five-year term to expire December 31, 2028.

24. Continuation of Citizen's Forum for Non-Agenda Items

25. New business

26. Other business

27. Adjourn

Haverford Township – Board of Commissioners

Meeting: Monday, February 12, 2024

Location: Commissioners Meeting Room – 1014 Darby Rd, Havertown, PA
19083

Regular Meeting Minutes

1. Opening of Meeting – Commissioner Holmes opened the meeting.

Roll Call – All 9 Commissioners were present at roll call: Commissioners Gondek, Forste-Grupp, McCloskey, Cavender, Quinn, Hart, McCollum, Trombetta and Holmes.

Also present were: David R. Burman, Township Manager, Ross Anderson, CPA, Township Auditor, John Walko, Esq., Township Solicitor, Aimee M. Cuthbertson, CPA, Assistant Township Manager, Chief John Viola, Brian Barrett, Parks and Recreation Director and Chuck Faulkner, Township Engineer.

Pledge of Allegiance

Announcement: The Board met in Executive Session prior to the Work Session last week to discuss Legal and Real Estate matters and also prior to tonight's meeting to discuss Real Estate matters.

2. Proclamations

Delaware County Chapter of the Pennsylvania Society of Professional Engineers 2024 Lifetime Achievement Award - Ed Magargee – presented by Commissioner Holmes

Recognizing and Celebrating Black History Month – presented by Commissioner Trombetta

3. Citizens Forum – 20 Minutes – Registered Speakers - 20 Minutes - Agenda Items

Registered Speakers

Mike Brenner – discussed the Pros Plan. The township should be proud. They need to be more responsive to the more vulnerable and be open to ADA individuals during this process. He is proposing additions to the plan.

End of registered speakers

Open Forum

Jamie Jallozian – Landover Road

Ms. Jallozian definitely supports the Pros Plan. There was a lot of public input.

Tony Morinelli's comments were read aloud by Commissioner Holmes regarding the Mill and Karakung Parking lot, pedestrian walking trails and the restoration of the Powder House.

Michelle Alvare's comments were read aloud by Commissioner Holmes regarding her support of the Pros Plan

4. Bureau of Fire Update -

Commissioner Gondek presented the January fire report.

5. Township Auditor Update -

Mr. Anderson reviewed the expenses and disbursements and found no irregularities.

6. Township Manager Update -

Township Manager David Burman offered updates on several ongoing projects in the Township. Residents can expect to see construction work at/near Manoa Road as they continue their work on the extension of Pennsy Trail. Interior demolition is nearly complete in the library; mechanical, electrical, and plumbing work is next. 1 Mill Road is currently being used as a lay-down area for the library renovation. The Darby Road Streetscapes Phase III project is underway is expected to take about 3 months to complete. The Mill & Karakung Park & Ride project is expected to take 2-3 months for completion. A very large tree (62" in diameter) fell at the Grange Estate; a crane is expected to come this week for its removal.

7. Approval of Minutes -

Motion made by Commissioner Quinn and seconded by Commissioner Trombetta to approve the Reorganization Meeting Minutes of January 2, 2024 and the Regular Meeting Minutes of January 8, 2024. Commissioner Gondek made a motion to amend vote during HRC appointment. He voted for Melissa Haub. Amendment was accepted.

Vote was unanimous. 9-0

8. Approval of Warrants -

Motion made by Commissioner McCloskey and seconded by Commissioner Trombetta to approve Warrant #2-2024 totaling \$4,770,342.85 and comprised of the following:

General Fund Disbursements in the amount of \$2,022,441.19

Sewer Fund Disbursements in the amount of \$214,974.93

Community Development Block Grant Fund Disbursements in the amount of \$44,344.81

Capital Projects Fund Disbursements in the amount of \$683,742.25

American Rescue Plan Fund in the amount of \$83,265.05

General & Sewer Fund Payroll for January 18, 2024 in the amount of \$921,992.76

General & Sewer Fund Payroll for February 1, 2024 in the amount of \$786,748.37

Credit Card Statement Ending January 27, 2024 in the amount of \$12,833.49

Vote was unanimous. 9-0

9. Appointment of Special Counsel -

Motion made by Commissioner McCloskey and seconded by Commissioner Cavender to appoint Jennifer W. Brown, Esq. of Eastburn & Gray, PC, Blue Bell, PA to serve as Township Act 511 Special Counsel for any matters related to the enforcement and administration of business privilege, mercantile and local services tax at a rate of \$250 per hour; on an as needed basis.

Vote was unanimous. 9-0

10. Ordinance No. P1-2024

Amending Chapter 95 – Recycling (2nd Reading)

Motion made by Commissioner Trombetta and seconded by Commissioner Cavender to adopt the second reading of Ordinance No. P1-2024 amending and supplementing the General Laws of the Township of Haverford Chapter 95, Article III Recycling, Sections 95-23 and 95-25 by adding a definition of Community Event and requiring organizers to provide separate containers for and to collect recyclable materials.

Vote was unanimous. 9-0

11. Ordinance No. P2-2024

Traffic (2nd Reading)

Motion made by Commissioner Quinn and seconded by Commissioner Hart to adopt the second reading of Ordinance No. P2-2024 establishing/rescinding traffic restrictions on the following highways:

Parking Time Limited:

Establish: On the west side of Allston Road from Brookline Boulevard to, but not including 1204 Allston Road, 15-minute parking from 8:00 a.m. to 4:00 p.m., Monday through Friday

Rescind: Parking of All Vehicles Prohibited at All Times:

East side of Allston Road from Brookline Boulevard to Sagamore

West side of Allston Road from Brookline Boulevard to a point 35 feet south thereof

Rescind: Special Purpose Parking Zones:

On the West side of Allston Road, approximately 75 feet south of its intersection with Brookline Boulevard

Vote was unanimous. 9-0

12. Ordinance No. P3-2024

Skatium – Café Lease Renewal (1st Reading)

Motion made by Commissioner Gondek and seconded by Commissioner Trombetta to adopt the first reading of Ordinance P3-2024 authorizing a renewal lease agreement with Shef & Sons, LLC dba Hav-A-Burger, Essington, PA for a portion of certain property located at 1018 Darby Road (the Skatium), Havertown, PA subject to review by the Township Solicitor and further subject to the approval of the Township Manager of the final document.

Vote was unanimous. 9-0

13. Ordinance No. P4-2024

Traffic (1st Reading)

Motion made by Commissioner Cavender and seconded by Commissioner Trombetta to adopt the first reading of Ordinance No. P4-2024 authorizing traffic restrictions on the following highways:

Establish: Special Purpose Parking Zones: In front of 2447 Wynnefield Drive

Establish: Parking of All Vehicles Prohibited at All Times: No Parking Here to Corner - the unit block of Colfax Road, north side, from the corner of Darby Road to a point 60 feet west.

Rescind: Permit Parking Only on Mifflin Avenue

Vote was unanimous. 9-0

14. Resolution No. 2360-2024

Subdivision/Land Development - 14 Claremont Blvd.

Motion made by Commissioner Cavender and seconded by Commissioner Gondek to adopt Resolution No. 2360-2024 approving the recommendations and findings of the Planning Commission are hereby adopted and the Preliminary / Final / Land Development Plan for Caramanico Homes, LLC, 14 Claremont Blvd., Haverford Township, Delaware County, dated November 30, 2023, is approved subject to compliance with the recommendations described hereinabove.

Motion was amended by Commissioner Cavender and seconded by Commissioner Gondek to include fee of \$8,437 in lieu of open space.

Vote was unanimous. 9-0

15. Resolution No. 2362-2024

Use of ARPA Funds - Police Department

Motion made by Commissioner Cavender and seconded by Commissioner Quinn to adopt Resolution No. 2362-2024 approving the use of funds from the Township's American Rescue Plan Fund allocation for the purchase of one (1) 2024 Landmaster AMP crew 4 x 4 electric ATV for a total of \$22,800.01.

Vote was unanimous. 9-0

16. Resolution No. 2363-2024
Grant Application - Library Construction

Motion made by Commissioner Forste-Grupp and seconded by Commissioner Cavender to adopt Resolution No. 2363-2024 approving that the Board of Commissioners of the Township of Haverford of Delaware County hereby acknowledges its support for an application to the Commonwealth of Pennsylvania, Department of Community and Economic Development, COVID-019 ARPA Capital Projects Fund Multi-Purpose Community Facilities Program in the amount of \$268,750 to assist with the construction and technology outfitting of the Maker's Space/Innovation Zone to be located within the newly renovated Haverford Township Free Library and that the Applicant does hereby designate David R. Burman, Township Manager and Aimee M Cuthbertson, Assistant Township Manager as the officials to execute all documents and agreements between the Township of Haverford and the Department of Community and Economic Development to facilitate and assist in obtaining the requested grant.

Vote was unanimous. 9-0

17. Resolution No. 2364-2024
Grant Application - Skatium Locker Rooms

Motion made by Commissioner Gondek and seconded by Commissioner Trombetta to adopt Resolution No. 2364-2024 approving that the Board of Commissioners of the Township of Haverford of Delaware County hereby acknowledges its support for an application to the Commonwealth of Pennsylvania, Department of Community and Economic Development, COVID-019 ARPA Capital Projects Fund Multi-Purpose Community Facilities Program in the amount of \$500,000 to assist with the space planning, construction and renovation of the locker rooms and related space at the Haverford Township Skatium; and, designating David R. Burman, Township Manager and Aimee M Cuthbertson, Assistant Township Manager as the officials to execute all documents and agreements between the Township of Haverford and the Department of Community and Economic Development to facilitate and assist in obtaining the requested grant.

Vote was unanimous. 9-0

18. Resolution No. 2365-2024
Use of ARPA Funds - Public Works Heavy Equipment

Motion made by Commissioner Forste-Grupp and seconded by Commissioner Quinn to adopt Resolution No. 2365-2024 that the Board of Commissioners of the Township of Haverford desires to make improvements and financial investments in several Township projects and initiatives in accordance with the allowable spending structure as described by the U.S. Department of Treasury's Final Rule, as follows:

One (1) 2024 F600 Chassis 4x4 SD Regular Cab 145" WB DRW XL (F6L) in an amount not to exceed \$63,335.00 under CoStars Contract #025-E22-381Fred Beans Ford of Mechanicsburg 6320 Carlisle Pike Mechanicsburg, Pennsylvania 17050

For Chassis listed above:

One (1) Multi-Lift XR5S-3050 Hook Lift 12,000 Capacity

One (1) 10' Stainless Steel Dump Body

One (1) 20 Gallon Stainless Steel Valve/Tank Combo

One (1) Stainless Steel Salt Spreader with Poly Spinner

in an amount not to exceed \$89,500.00 under CoStars Contract #025-E22-432 Stephenson Equipment, INC. 4210 Chambers Hill Rd. Harrisburg, PA 17111

One (1) 11' Steel Flat Bed with Side Pockets Mounted in an amount not to exceed \$18,500.00 under CoStars Contract #025-E22-432 Stephenson Equipment, INC. 4210 Chambers Hill Rd. Harrisburg, PA 17111

One (1) Western 9' Pro Plus Snow Plow in an amount not to exceed \$8,000.00 under CoStars Contract# 025-E22-432 Stephenson Equipment, INC. 4210 Chambers Hill Rd. Harrisburg, PA 17111

One (1) 2-Ton Falcon Asphalt Recycler & Hot Box Hook Lift in an amount not to exceed \$40,911.20 under CoStars Contract# 025-E22-432 Stephenson Equipment, INC. 4210 Chambers Hill Rd. Harrisburg, PA 17111

One (1) 2024 Caterpillar 938 Front End Loader in an amount not to exceed \$281,165.00 under CoStars Contract #4400011420 Folly Cat INC. 855 Centennial Ave. Piscataway, NJ 08855

One (1) 2024 Broom Bear Sweeper on International Cab and Chassis in an amount not to exceed \$407,000.00 under CoStars Contract #025-E22-471GranTurk Equipment Co., INC. 1 Schuylkill Parkway, Bldg. B, Bridgeport, PA 19405

One (1) 2024 Brush Bandit 18 Inch Chipper with Winch in an amount not to exceed \$98,715.00 under CoStars Contract #4400028339 SEI Stephenson Equipment, INC. 4210 Chambers Hill Rd. Harrisburg, PA 17111

Three (3) SaltDogg Pro1500 Electric Poly Hopper Spreaders with Auger in an amount not to exceed \$14,000.00 under CoStars Contract #4400028339 SEI Stephenson Equipment, INC. 4210 Chambers Hill Rd. Harrisburg, PA 17111

Vote was unanimous. 9-0

19. Resolution No. 2366-2024

Announcement of Public Hearing- Zoning – Amending Chapter 47 entitled Amusement Devices

Motion made by Commissioner Cavender and seconded by Commissioner Quinn to adopt Resolution No. 2366-2024 amending Chapter 47 entitled “Amusement Devices” of the

General Laws of the Township of Haverford to further regulate the premises within which such devices may be permitted and associated definitions; amending Chapter 182 entitled “Zoning” to clarify the definition of Convenience Store, to define E-Liquids, Electronic Cigarettes, Electronic Nicotine Delivery Systems, Game of Skill Machines, Hookah Bars, Indoor Recreational or Amusement Facilities, Mechanical Amusement Devices, Significant Tobacco Retailers and Smoke Shops; to prohibit Mechanical Amusement Devices within the premises of Significant Tobacco Retailers and to prohibit Game of Skill Machines in Convenience Stores; to expressly prohibit Significant Tobacco Retailers in the C-2 Neighborhood Commercial District; to delete cigarette and tobacco as permitted to be sold in gift shops in the C-3 General Commercial District; to establish Significant Tobacco Retailers including Smoke Shops, Vape Shops and Hookah Lounges as a use permitted by Conditional Use in the C-5 Shopping Center Commercial District; and to establish the criteria for the approval of a Significant Tobacco Retailers use.

Motion was amended by Commissioner Gondek to include preamble. Both Commissioners Cavender and Quinn agreed.

Vote was unanimous. 9-0

20. Resolution No. 2367-2024

Preliminary/Final Plan – 2224-2228 Haverford Road

Motion made by Commissioner Gondek and seconded by Commissioner Forste-Grupp to Table Resolution No. 2367-2024.

Vote was unanimous. 9-0

21. Approval:

Motion made by Commissioner Quinn and seconded by Commissioner McCollum to approve Chief of Police contract extension retroactively from 1/4/2024 to 1/4/2026.

Vote was unanimous. 9-0

Motion made by Commissioner Hart and seconded by Commissioner Trombetta to approve the Park, Recreation & Open Space Plan

Vote was unanimous. 9-0

22. Purchases:

Police Department

Motion made by Commissioner Cavender and seconded by Commissioner Quinn to authorize the purchase of three (3) 2024 Chevrolet Tahoe Police Vehicles and two (2) 2024 Electric Chevrolet Blazer Police Vehicles 1MF26, under CoStars Contract #013-E22-264, from Whitmoyer Auto Group, 1001 East Main Street, Mount Joy, PA, in the amount of \$278,800.

Motion: to authorize the purchase of one (1) 2024 Landmaster AMP Crew 4 x 4 from Wide World West Chester, PA in the amount of \$22,800.01

Vote was unanimous. 9-0

Public Works Department from the General Operating and Capital Project Budgets

Motion made by Commissioner Forste-Grupp and seconded by Commissioner Trombetta to authorize the purchase of:

2024 Ford F350 Regular Cab with 9ft Western Pro Plus Plow in the amount of \$66,110.00 under CoStars Contract #025-E22-387 from Hondru Ford, Manheim, PA

2024 Ford F350 Super Cab with 9ft Western Pro Plus Plow in the amount of \$70,060.00 under CoStars Contract #025-E22-387 from Hondru Ford, Manheim, PA

2024 Altec 75ft Tree Bucket Truck with International Cab & Chassis in the amount of \$299,000.00 under CoStars Contract #4400019945 from Altec, Inc, Plains, PA

2024 International Cab & Chassis HV607 for Recycling Truck in the amount of \$128,164.40 under CoStars Contract #025-E22-471 from GranTurk Equipment Co. Inc, Bridgeport, PA

2024 Recycling Body (20-yard) for Cab & Chassis noted above in the amount of \$108,373.00 under CoStars Contract #025-E23-577 from Ascendence Trucks, Swedesboro, NJ

Pole Barn (1) with Concrete Pad in the amount of \$50,000.00 CoStars Contract #008-E23-1096 from Shirk Pole Buildings LLC, East Earl, PA

Vote was unanimous. 9-0

Public Works Department from ARPA Funds

Motion made by Commissioner Forste-Grupp and seconded by Commissioner Cavender to authorize the purchase of:

One (1) 2024 F600 Chassis 4x4 SD Regular Cab 145" WB DRW XL (F6L) in an amount not to exceed \$63,335.00 under CoStars Contract #025-E22-381 from Fred Beans Ford of Mechanicsburg 6320 Carlisle Pike Mechanicsburg, Pennsylvania 17050

For Chassis listed above:

One (1) Multi-Lift XR5S-3050 Hook Lift 12,000 Capacity

One (1) 10' Stainless Steel Dump Body

One (1) 20 Gallon Stainless Steel Valve/Tank Combo

One (1) Stainless Steel Salt Spreader with Poly Spinner

in an amount not to exceed \$89,500.00 under CoStars Contract #025-E22-432 from Stephenson Equipment, INC. 4210 Chambers Hill Rd. Harrisburg, PA 17111

One (1) 11' Steel Flat Bed with Side Pockets Mounted in an amount not to exceed \$18,500.00 under CoStars Contract #025-E22-432 from Stephenson Equipment, INC. 4210 Chambers Hill Rd. Harrisburg, PA 17111

One (1) Western 9' Pro Plus Snow Plow in an amount not to exceed \$8,000.00 under CoStars Contract# 025-E22-432 from Stephenson Equipment, INC. 4210 Chambers Hill Rd. Harrisburg, PA 17111

One (1) 2-Ton Falcon Asphalt Recycler & Hot Box Hook Lift in an amount not to exceed \$40,911.20 under CoStars Contract# 025-E22-432 Stephenson Equipment, INC. 4210 Chambers Hill Rd. Harrisburg, PA 17111

One (1) 2024 Caterpillar 938 Front End Loader in an amount not to exceed \$281,165.00 under CoStars Contract #4400011420 from Folly Cat INC. 855 Centennial Ave. Piscataway, NJ 08855

One (1) 2024 Broom Bear Sweeper on International Cab and Chassis in an amount not to exceed \$407,000.00 under CoStars Contract #025-E22-471 from GranTurk Equipment Co., INC. 1 Schuylkill Parkway, Bldg. B, Bridgeport, PA 19405

One (1) 2024 Brush Bandit 18 Inch Chipper with Winch in an amount not to exceed \$98,715.00 under CoStars Contract #4400028339 from SEI Stephenson Equipment, INC. 4210 Chambers Hill Rd. Harrisburg, PA 17111

Motion amended to add purchase by Commissioner Forste-Grupp and seconded by Commissioner Cavender:

Three (3) SaltDogg Pro1500 Electric Poly Hopper Spreaders with Auger in an amount not to exceed \$14,000.00 under CoStars Contract #4400028339 from SEI Stephenson Equipment, INC. 4210 Chambers Hill Rd. Harrisburg, PA 17111

Vote was unanimous. 9-0

23. Appointments:

Motion was amended by Commissioner Hart and seconded by Commissioner Forste-Grupp to nominate Commissioner Laura Cavender as a Board of Director to the Bryn Mawr Playfield Association.

Civil Service Commission - Alternate

Motion made by Commissioner Cavender and seconded by Commissioner Hart to appoint Monet Reilly to fill an unexpired six (6) year term to expire December 31, 2029.

Motion made by Commissioner McCollum and seconded by Commissioner Quinn to appoint Mr. Stevenson.

Motion to close made by Commissioner Trombetta and seconded by Commissioner Cavender.

6 votes for Ms. Reilly: Commissioners Forste-Grupp, McCloskey, Cavender, Hart, Trombetta and Holmes

3 votes for Mr. Stevenson: Commissioners Gondek, Quinn and McCollum

Friends of the Grange

Motion made by Commissioner Quinn and seconded by Commissioner Hart to appoint to fill an unexpired two (2) year term to expire December 31, 2024.

Motion to close made by Commissioner Trombetta and seconded by Commissioner Cavender.

Vote was unanimous. 9-0

Senior Citizen Advisory Board - 6th Ward Only - Commissioner Holmes passed.

Vacancy Committee - Motion: made by Commissioner Quinn and seconded by Commissioner McCollum to appoint Kevin McNicholas to serve on the Vacancy Committee for a one-year term to expire December 31, 2024.

Motion to close made by Commissioner Gondek and seconded by Commissioner Quinn.

8 voted Yes. Commissioner Cavender abstained.

Vacant Property Review Committee - Motion: to appoint (space for name to be filled in after voting is completed) to serve on the Vacant Property Review Committee for a five-year term to expire December 31, 2028.

Motion made by Commissioner Trombetta and seconded by Commissioner Quinn to Table.

Vote was unanimous. 9-0

24. Continuation of Citizen's Forum for Non-Agenda Items

Todd Hall – 2nd Ward resident

Mr. Hall indicated that he received correspondence from a township employee who had pronouns and gender identity under their name. His opinion is that individuals need to stick to the subject matter only. There should not be any native-cultural quotes in emails.

Michael Lee

The Board is always talking about inclusivity, transparency and communication. He meant, when the board meets in Executive Session to discuss legal or real estate. He wants to know if this affects him. He also spoke on the proposed smoke shop locations. The township is just moving the problem to another area.

Beth Wagner – Rosewood Lane

She announced that she won a tree in the Shade Tree Lottery and thanked the board and the taxpayers for her tree. She recently attended a Planning Commission meeting and the Municipal Exemption was discussed. There was no mention of the Haverford Road Diet, Billboards, the Polo Field or the Comp Plan.

Commissioner Holmes responded to Mr. Lee's comments. The Work Session is for Board discussion only as it pertains to real estate matters.

In response to Ms. Wagner – Billboards is in litigation, Haverford Road Diet is a PennDot project. The board is still waiting feedback on the Comp Plan review and there is not mention yet on Municipal Exemption.

25. New business

Commissioner Gondek stated that on January 30, the Ordinance Committee met to review the Municipal Exemption and Smoke Shop Ordinance.

26. Other business

1st Ward Commissioner Brian Gondek

With the Proclamation for Black History Month being read tonight, we still have a lot more work to do to become friendlier and more inclusive.

Happy Valentine's Day to everyone. Please keep your vehicles off the street with the bad weather coming.

West Gate Hills will hold their Easter Egg Hunt on March 23rd at 1:00 p.m.

He offered thanks and respect to all first responders especially the recent police incident that occurred in East Lansdowne.

2nd Ward Commissioner Sheryl Forste-Grupp, PhD

Commissioner Forste-Grupp reminded everyone to pay their fire company annual dues.

She also reminded everyone that many black individuals were involved in inventions, technology, science and many other areas. We all need to learn something new each day.

3rd Ward Commissioner Kevin McCloskey, Esq.

Commissioner McCloskey announced that February 16 is the deadline to apply for the Haverford Township Business Revitalization and Modernization Matching (BRMM) Grant Program. Businesses in Haverford Township are encouraged to apply.

A Rain Garden Workshop will be held on March 2nd up at the CREC.

5th Ward Commissioner Laura Cavender

Bryn Mawr Civic Association will hold their Spring Fling on April 6th. There will be quite a few 5K Runs coming up.

Commissioner Cavender expressed her thoughts on the Gaza situation and hopes for a peaceful solution.

7th Ward Commissioner Conor Quinn

Commissioner Quinn reminded everyone to please remember our police and fire fighters every day.

8th Ward Commissioner Gerry Hart

Penfield Civic Association will host a Happy Hour on 2/22 – 6 p.m. at McGuilicuddys. Commissioner Hart spoke on the book; The Hill We Climb...we are in dark times.

9th Ward Commissioner Mike McCollum

Thanks to the Public Works Department and Dan Mariani for the job they did last month with the snow. Trash/Recycling were all picked up!

Commissioner McCollum gave a warm Welcome Home to the 9th Ward resident police officer that was shot during the East Lansdowne episode.

He congratulated the Police Department for citing various smoke shops for selling to minors.

4th Ward Commissioner Judy Trombetta

Commissioner Trombetta reminded businesses that February 16 is the deadline to apply for the Haverford Township Business Revitalization and Modernization Matching (BRMM) Grant Program. Businesses in Haverford Township are encouraged to apply for projects related to renovating interior and exterior areas, purchasing and/or installing energy-efficient equipment, or implementing technology upgrades to enhance online purchasing and customer engagement.

6th Ward Commissioner Larry Holmes

In response to Mr. Hall's pronoun comments: Township employee is telling other they respect who they are.

27. Adjourn

All Commissioners agreed to adjourn.

Haverford Township
Disbursements for Approval - Warrant # 2 - 2024
February 12, 2024

(Formatted for ADA Accessibility)

General Fund		\$	2,022,441.19
Sewer Fund		\$	214,974.93
Community Development Block Grant Fund		\$	44,344.81
Capital Projects Fund		\$	683,742.25
American Rescue Plan Fund		\$	83,265.05
Total		\$	3,048,768.23

Payroll for January 18, 2024

General Fund	\$	902,570.25	
Sewer Fund	\$	19,422.51	\$ 921,992.76

Payroll for February 1, 2024

General Fund	\$	765,891.27	
Sewer Fund	\$	20,857.10	\$ 786,748.37

Credit Card Statement Ending January 27, 2024

\$ 12,833.49

Total Disbursements

\$ 4,770,342.85

These bills have been approved by the respective department heads, the Assistant Township Manager and Township Manager. Additionally, they have been processed by the Finance Department and are within total 2024 budgetary limits as imposed by the Board of Commissioners at its December 11, 2023 stated meeting.

Submitted to and approved by the Board of Commissioners this 12th day February, 2024

Haverford Township
 Invoices by GL Distribution Account
 (Formatted for ADA Accessibility)

Invoice GL Account Title	Payee	Invoice Date	Description	GL Period Date	Check Amount	Check Issue Date	Check Number
American Rescue Plan Fund							
3440907402							
ARPA - Economic Impacts	All Seasons Landscaping Co. Inc.	1/8/2024	WCP Median Landscaping	1/31/2024	\$ 21,490.00	2/12/2024	7102
ARPA - Economic Impacts	Pennoni Associates, Inc	2/1/2024	West Chester Pike Median Landscaping	1/31/2024	\$ 870.00	2/12/2024	7107
ARPA - Economic Impacts	Pennoni Associates, Inc	2/1/2024	Darby Road Streetscape - Phase 3	1/31/2024	\$ 772.25	2/12/2024	7107
Total 03440907402:					\$ 23,132.25		
3440907502							
ARPA - General Government	Element Environmental Solutions Inc	12/29/2023	Asbestos Inspect - 1 Mill Rd	1/31/2024	\$ 1,020.00	2/12/2024	7103
ARPA - General Government	Element Environmental Solutions Inc	1/23/2024	Abatement Oversight - 1 Mill Rd	1/31/2024	\$ 1,645.00	2/12/2024	7103
ARPA - General Government	Pennoni Associates, Inc	2/1/2024	Twp Bldg Electric Vehicle Charging Station	1/31/2024	\$ 147.50	2/12/2024	7107
Total 03440907502:					\$ 2,812.50		
3440907602							
ARPA - Water, Sewer, Broadband	N Abbonizio Contractors, Inc	2/2/2024	Storm Sewer Replacement - Frederick Rd to Ellis Rd	1/31/2024	\$ 23,516.08	2/12/2024	7105
ARPA - Water, Sewer, Broadband	Penndot	10/2/2023	Brookline Blvd Project (HOP #06114940)	1/31/2024	\$ 140.00	2/12/2024	7106
ARPA - Water, Sewer, Broadband	Pennoni Associates, Inc	2/1/2024	S/S Township Wide	1/31/2024	\$ 2,136.75	2/12/2024	7107
ARPA - Water, Sewer, Broadband	Pennoni Associates, Inc	2/1/2024	Bailey Park - 2022 Small Water_Sewer Grant	1/31/2024	\$ 105.00	2/12/2024	7107
ARPA - Water, Sewer, Broadband	Pennoni Associates, Inc	2/1/2024	Brookline Blvd Sewer Replacement	1/31/2024	\$ 290.00	2/12/2024	7107
ARPA - Water, Sewer, Broadband	Pennoni Associates, Inc	2/1/2024	County Line Road Sewer Lining	1/31/2024	\$ 641.00	2/12/2024	7107
ARPA - Water, Sewer, Broadband	Pennoni Associates, Inc	2/1/2024	Crescent Hill_Francis Drive Lining	1/31/2024	\$ 140.00	2/12/2024	7107
ARPA - Water, Sewer, Broadband	Pennoni Associates, Inc	2/1/2024	Cobbs Creek Interceptor Buttressing	1/31/2024	\$ 527.50	2/12/2024	7107
ARPA - Water, Sewer, Broadband	Pennoni Associates, Inc	2/1/2024	Storm Sewer Replacement - Frederick Rd to Ellis Rd	1/31/2024	\$ 36.25	2/12/2024	7107
ARPA - Water, Sewer, Broadband	Pennoni Associates, Inc	2/1/2024	Northbrook Stream Restoration	1/31/2024	\$ 7,770.00	2/12/2024	7107
ARPA - Water, Sewer, Broadband	Pennoni Associates, Inc	2/1/2024	Cobbs Creek Stream Restoration	1/31/2024	\$ 4,897.00	2/12/2024	7107
ARPA - Water, Sewer, Broadband	Pennoni Associates, Inc	2/1/2024	Dill Road Storm Sewer Lining	1/31/2024	\$ 140.00	2/12/2024	7107
Total 03440907602:					\$ 40,339.58		
3440907802							
ARPA - Disprpt'ly Impctd	Christine Fanelli	12/28/2023	Senior Economic Recovery Payment	1/31/2024	\$ 500.00	1/9/2024	7091
ARPA - Disprpt'ly Impctd	Julio S. Paz Y Mino	1/10/2024	Senior Economic Recovery Payment	1/31/2024	\$ 500.00	1/16/2024	7094
ARPA - Disprpt'ly Impctd	LogoWear House Inc	9/29/2023	(200) Shirts - Senior/Fitness Expo TShirts (10/01/23)	1/31/2024	\$ 980.00	1/16/2024	7095
ARPA - Disprpt'ly Impctd	Edward Konieczny	1/22/2024	Senior Economic Recovery Payment	1/31/2024	\$ 500.00	1/23/2024	7096
ARPA - Disprpt'ly Impctd	Maryann Dugan	1/25/2024	Senior Economic Recovery Payment	1/31/2024	\$ 500.00	1/23/2024	7097
ARPA - Disprpt'ly Impctd	Maryann Dugan	1/25/2024	Senior Economic Recovery Payment	1/31/2024	\$ (500.00)	1/29/2024	7097
ARPA - Disprpt'ly Impctd	Scott Selkowitz	1/24/2024	Reimb - Senior Game Night	1/31/2024	\$ 80.62	1/23/2024	7098
ARPA - Disprpt'ly Impctd	Scott Selkowitz	1/24/2024	Reimb - Senior Game Night	1/31/2024	\$ (80.62)	1/29/2024	7098
ARPA - Disprpt'ly Impctd	Maryann Dugan	1/25/2024	Senior Economic Recovery Payment	1/31/2024	\$ 500.00	1/30/2024	7099
ARPA - Disprpt'ly Impctd	Scott Selkowitz	1/24/2024	Reimb - Senior Game Night	1/31/2024	\$ 80.62	1/30/2024	7100
ARPA - Disprpt'ly Impctd	Dolores E Brough	1/31/2024	Senior Economic Recovery Payment	2/29/2024	\$ 500.00	2/6/2024	7101
ARPA - Disprpt'ly Impctd	Pennoni Associates, Inc	2/1/2024	Township Line Sidewalks	1/31/2024	\$ 326.25	2/12/2024	7107
Total 03440907802:					\$ 3,886.87		
3440908102							
ARPA - Health Response	FencCo Inc	1/18/2024	Install Chain Link Fence - McDonald Field	1/31/2024	\$ 11,000.00	2/12/2024	7104
ARPA - Health Response	Pennoni Associates, Inc	1/25/2024	Grange_Preston Basketball Court Reno	1/31/2024	\$ 372.60	2/12/2024	7107
ARPA - Health Response	Pennoni Associates, Inc	2/1/2024	Darby Creek Trails - Southern Extension	1/31/2024	\$ 1,721.25	2/12/2024	7107
Total 03440908102:					\$ 13,093.85		
Total American Rescue Plan Fund:					\$ 83,265.05		
Capital Fund							
18440907302							
Capital Projects	Pennoni Associates, Inc	2/1/2024	Raymond Drive Basin	1/31/2024	\$ 3,441.25	2/12/2024	1138
Capital Projects	Richard E Pierson Construction Inc	12/14/2023	Pennsy Trail Construction App #3	1/31/2024	\$ 96,590.05	1/16/2024	1415
Capital Projects	Traffic Planning and Design, Inc	12/6/2023	Construction Inspec - Pennsy Trail	1/31/2024	\$ 17,420.30	1/16/2024	1416
Capital Projects	CDW Government Inc	1/13/2024	HPE Server	1/31/2024	\$ 13,115.50	2/12/2024	1417
Capital Projects	Herbert Rowland and Grubic, Inc	1/12/2024	Parks & Rec Open Space Plan	1/31/2024	\$ 3,757.22	2/12/2024	1418

Capital Projects	Michael Baker International, Inc	1/11/2024	Wynnefield Drive Flood Study	1/31/2024	\$	12,364.98	2/12/2024	1419
Capital Projects	Pennoni Associates, Inc	2/1/2024	DCED Trans Grant Mill & Karakung	1/31/2024	\$	458.25	2/12/2024	1420
Capital Projects	Pennoni Associates, Inc	2/1/2024	Pennsy Trail - Phase II	1/31/2024	\$	729.50	2/12/2024	1420
Capital Projects	Pennoni Associates, Inc	2/1/2024	CREC Electric Vehicle Charging Station	1/31/2024	\$	6,986.00	2/12/2024	1420
Capital Projects	Signal Service, Inc	10/6/2023	Earlington & Mill	1/31/2024	\$	14,887.40	2/12/2024	1421
Capital Projects	Wiss, Janney, Elstner Associates, Inc.	1/16/2024	Veneer Failure Investigation	1/31/2024	\$	1,797.40	2/12/2024	1422
Capital Projects	McCloskey Mechanical Contractors, Inc	2/1/2024	Skatium Cooling Towers Replacement	1/31/2024	\$	67,321.80	2/12/2024	7016
Capital Projects	Pennoni Associates, Inc	2/1/2024	Skatium Cooling Towers	1/31/2024	\$	5,473.00	2/12/2024	7017
Capital Projects	Pennoni Associates, Inc	2/1/2024	Skatium Locker Room Renovations	1/31/2024	\$	333.75	2/12/2024	7017
Capital Projects	Schipsi Electric, LLC	2/1/2024	Skatium Cooling Towers Replacement	1/31/2024	\$	5,492.70	2/12/2024	7018
Capital Projects	Flag Products Inc	10/31/2023	Signage Balance - Temp Library Location	1/31/2024	\$	3,589.50	1/16/2024	8055
Capital Projects	AJM Electric, Inc	1/25/2024	Library - Prime (Electrical)	1/31/2024	\$	17,775.00	2/12/2024	8056
Capital Projects	Bernardon Architects	1/18/2024	Haverford Township Library	1/31/2024	\$	6,241.36	2/12/2024	8057
Capital Projects	Bristol Environmental inc	11/12/2023	Mold Remediation - 2325 Darby Rd	1/31/2024	\$	12,300.00	2/12/2024	8058
Capital Projects	C.B. Development Services, Inc	1/9/2024	Haverford Township Library	1/31/2024	\$	31,950.00	2/12/2024	8059
Capital Projects	C.B. Development Services, Inc	1/30/2024	Haverford Township Library	1/31/2024	\$	31,950.00	2/12/2024	8059
Capital Projects	Corcoran Drilling Co Inc	12/30/2023	Haverford Township Library Parking Lot	1/31/2024	\$	1,950.00	2/12/2024	8060
Capital Projects	David Blackmore & Associates Inc	1/12/2024	Geotechnical Exploration - Haverford Township Library	1/31/2024	\$	4,698.48	2/12/2024	8061
Capital Projects	Delaware County Intermediate Unit	1/12/2024	IT - Temporary Locations	1/31/2024	\$	12,754.08	2/12/2024	8062
Capital Projects	Dolan Mechanical, Inc	1/31/2024	Library - Prime (HVAC)	1/31/2024	\$	69,210.00	2/12/2024	8063
Capital Projects	Dolan Mechanical, Inc	1/31/2024	Library - Prime (Plumbing)	1/31/2024	\$	54,925.20	2/12/2024	8063
Capital Projects	Element Environmental Solutions Inc	8/22/2023	UST Removal - 1601 Darby Rd	1/31/2024	\$	408.00	2/12/2024	8064
Capital Projects	Element Environmental Solutions Inc	12/29/2023	UST Removal - 1601 Darby Rd	1/31/2024	\$	1,153.35	2/12/2024	8064
Capital Projects	Element Environmental Solutions Inc	12/29/2023	Mold Reporting - 2325 Darby Rd	1/31/2024	\$	1,046.50	2/12/2024	8064
Capital Projects	Element Environmental Solutions Inc	12/29/2023	Abatement Oversight - 1601 Darby Rd	1/31/2024	\$	6,000.00	2/12/2024	8064
Capital Projects	Excel Elevator & Escalator LLC	12/27/2023	Elevator Repair - 1601 Darby Rd	1/31/2024	\$	850.00	2/12/2024	8065
Capital Projects	Keystone Municipal Services, Inc	12/30/2023	Plan Review (Library)	1/31/2024	\$	37.50	2/12/2024	8066
Capital Projects	Pennoni Associates, Inc	2/1/2024	Township Building Solar	1/31/2024	\$	848.75	2/12/2024	8067
Capital Projects	Rycon Construction, Inc	1/26/2024	Library - Prime (GC)	1/31/2024	\$	164,159.78	2/12/2024	8068
Capital Projects	Spidernet Technical Consulting, LLC	12/31/2023	IT - Temporary Locations	1/31/2024	\$	7,203.52	2/12/2024	8069
Capital Projects	Spidernet Technical Consulting, LLC	12/31/2023	IT - Temporary Locations	1/31/2024	\$	4,522.13	2/12/2024	8069
	Total 18440907302:				\$	683,742.25		
	Total Capital Fund:				\$	683,742.25		
CDBG Grant Fund								
4494750602								
Administration	Anthony J Dunleavy Assoc Inc	2/1/2024	48th Yr Rehab	1/31/2024	\$	11,700.00	2/12/2024	4773
	Total 04494750602:				\$	11,700.00		
4494750802								
Public Projects	S.B. Conrad, Inc	12/19/2023	Grange/Preston Basketball Court Restoration	1/31/2024	\$	7,040.06	1/9/2024	4771
Public Projects	Pennoni Associates, Inc	1/24/2024	Grange Estate Necessary Roof	1/31/2024	\$	72.50	2/12/2024	4775
	Total 04494750802:				\$	7,112.56		
4494751302								
Rehabilitation	AJP Contractors Inc	1/16/2024	717 Aubrey Ave	1/31/2024	\$	2,700.00	2/12/2024	4772
Rehabilitation	Leadco Environmental Services Inc	11/17/2023	2421 Wynnefield Dr	1/31/2024	\$	1,759.00	2/12/2024	4774
Rehabilitation	Pennoni Associates, Inc	1/25/2024	Misc HUD Inspections	1/31/2024	\$	616.25	2/12/2024	4775
	Total 04494751302:				\$	5,075.25		
4495750602								
Administration	Anthony J Dunleavy Assoc Inc	2/1/2024	49th Yr Admin	1/31/2024	\$	13,300.00	2/12/2024	4773
	Total 04495750602:				\$	13,300.00		
4495750802								
Public Projects	Pennoni Associates, Inc	12/22/2023	Grange_Preston Basketball Court Reno	1/31/2024	\$	981.60	1/9/2024	4770
Public Projects	Pennoni Associates, Inc	1/25/2024	Grange_Preston Basketball Court Reno	1/31/2024	\$	662.40	2/12/2024	4775
	Total 04495750802:				\$	1,644.00		
4495751402								
Senior Citizens Services	Surrey Services for Seniors	12/1/2023	49th Yr Senior Center	1/31/2024	\$	5,513.00	2/12/2024	4776
	Total 04495751402:				\$	5,513.00		
	Total CDBG Grant Fund:				\$	44,344.81		

General Fund

110007								
Cash on Hand - Skatium	Petty Cash - Haverford Township	1/18/2024	For POS - Skatium	1/31/2024	\$	300.00	1/23/2024	182305
Total 0110007:					\$	300.00		
113000								
Due From Other Funds	Peco Energy	12/28/2023	Lawrence Rd - Darby Creek	1/31/2024	\$	4.67	1/9/2024	182256
Due From Other Funds	Peco Energy	12/28/2023	Darby Creek - Ellis	1/31/2024	\$	4.67	1/9/2024	182256
Due From Other Funds	Peco Energy	12/28/2023	Marple Rd - Darby Creek	1/31/2024	\$	4.67	1/9/2024	182256
Due From Other Funds	Peco Energy	12/28/2023	Bon Air - Darby Creek	1/31/2024	\$	4.67	1/9/2024	182256
Due From Other Funds	Peco Energy	12/28/2023	Glendale Rd - Darby Creek	1/31/2024	\$	4.67	1/9/2024	182256
Due From Other Funds	Peco Energy	12/28/2023	3800 Darby Rd	1/31/2024	\$	4.67	1/9/2024	182256
Due From Other Funds	Peco Energy	12/28/2023	West Chester Pk - Walnut Hill	1/31/2024	\$	4.67	1/9/2024	182256
Due From Other Funds	Postmaster	1/26/2024	2024 Tax Bill Postage	1/31/2024	\$	3,531.93	1/26/2024	182310
Due From Other Funds	Peco Energy	1/29/2024	Lawrence Rd - Darby Creek	2/29/2024	\$	4.69	2/6/2024	182339
Due From Other Funds	Peco Energy	1/29/2024	Darby Creek - Ellis	2/29/2024	\$	4.69	2/6/2024	182339
Due From Other Funds	Peco Energy	1/29/2024	Marple Rd - Darby Creek	2/29/2024	\$	4.69	2/6/2024	182339
Due From Other Funds	Peco Energy	1/29/2024	Bon Air - Darby Creek	2/29/2024	\$	4.69	2/6/2024	182339
Due From Other Funds	Peco Energy	1/29/2024	Glendale Rd - Darby Creek	2/29/2024	\$	4.69	2/6/2024	182339
Due From Other Funds	Peco Energy	1/29/2024	3800 Darby Rd	2/29/2024	\$	4.69	2/6/2024	182339
Due From Other Funds	Peco Energy	1/29/2024	West Chester Pk - Walnut Hill	2/29/2024	\$	4.69	2/6/2024	182339
Total 0113000:					\$	3,597.45		
123900								
Over and Duplicate Payments	Diane M Hannold	1/5/2024	Overpym't RE Taxes #22030165700	1/31/2024	\$	81.34	1/16/2024	182273
Total 0123900:					\$	81.34		
1360360601								
Bulk Trash Fees	Rachel Loev	1/24/2024	Refund - Canceled Bulk	1/31/2024	\$	22.00	1/30/2024	182323
Total 01360360601:					\$	22.00		
1360364101								
Lessons	Kate D'Arcy Edmiston	1/11/2024	Refund - Canceled Lessons	1/31/2024	\$	150.00	1/16/2024	182283
Total 01360364101:					\$	150.00		
1400150002								
Life Insurance	North American Benefits Company	1/22/2024	Group Term Life Insurance	1/31/2024	\$	172.80	1/30/2024	182320
Total 01400150002:					\$	172.80		
1400150502								
Health Benefits	DelCo Public Schools Healthcare Trst	1/2/2024	Health Benefits	1/31/2024	\$	22,485.91	1/16/2024	182272
Total 01400150502:					\$	22,485.91		
1400151002								
Rx/Dental/Vision/LTD	Express Scripts Inc	1/2/2024	Prescription Benefits	1/31/2024	\$	836.67	1/9/2024	422
Rx/Dental/Vision/LTD	Express Scripts Inc	1/12/2024	Prescription Benefits	1/31/2024	\$	1,276.31	1/12/2024	426
Rx/Dental/Vision/LTD	Express Scripts Inc	1/22/2024	Prescription Benefits	1/31/2024	\$	739.43	1/30/2024	430
Rx/Dental/Vision/LTD	Express Scripts Inc	1/2/2024	Prescription Benefits	1/31/2024	\$	836.67	1/9/2024	7092
Rx/Dental/Vision/LTD	Express Scripts Inc	1/2/2024	Prescription Benefits	1/31/2024	\$	(836.67)	1/9/2024	7092
Rx/Dental/Vision/LTD	North American Benefits Company	1/22/2024	Long Term Civilian Disability Insurance	2/29/2024	\$	132.59	2/6/2024	182337
Total 01400151002:					\$	2,985.00		
1400152002								
Workers Compensation	Arthur J Gallagher Risk Mgmt Serv Inc	1/8/2024	2022 WC Audit	1/31/2024	\$	221.73	1/16/2024	182263
Total 01400152002:					\$	221.73		
1400200002								
Miscellaneous Expense	Bridgee Bees Floral Creations LLC	1/19/2024	Speedy Recovery - L Latanzio	1/31/2024	\$	70.00	2/12/2024	182370
Miscellaneous Expense	Spike's Trophies Limited	11/25/2023	Desk Name Plate - M McCollum	1/31/2024	\$	95.00	2/12/2024	182494
Total 01400200002:					\$	165.00		
1400200102								
Commissioners Expense	Dawn Griffin	1/12/2024	Deposit - BOC Childrens Outreach Books	1/31/2024	\$	675.00	1/16/2024	182269
Commissioners Expense	Strassheim Digital Imaging	1/16/2024	Postage & Delivery - Ward 2, 7, 8 Mgt	1/31/2024	\$	1,656.61	1/23/2024	182307
Commissioners Expense	Strassheim Digital Imaging	1/17/2024	Postcard Printing - Ward 2, 7, 8 Mtg	1/31/2024	\$	2,195.00	1/23/2024	182307
Commissioners Expense	AT & T Mobility	1/16/2024	Cellular Service	2/29/2024	\$	402.55	2/6/2024	182331
Commissioners Expense	Suzanne Guelli	1/9/2024	Ward 2, 7, 8 Postcard	2/29/2024	\$	100.00	2/6/2024	182343
Commissioners Expense	D M I Home Supply	12/13/2023	Holiday Party for Employees	1/31/2024	\$	518.00	2/12/2024	182384
Commissioners Expense	Taddeo's Greenhouse Inc	12/12/2023	Holiday Flowers - Employee Luncheon	1/31/2024	\$	120.00	2/12/2024	182500

Total 01400200102:					\$	5,667.16		
1400200202								
Office Supplies	Office Basics, Inc	12/11/2023	Office Supplies	1/31/2024	\$	70.54	2/12/2024	182462
Office Supplies	Office Basics, Inc	1/2/2024	Office Supplies	1/31/2024	\$	9.40	2/12/2024	182462
Office Supplies	Office Basics, Inc	1/4/2024	Office Supplies	1/31/2024	\$	81.93	2/12/2024	182462
Office Supplies	Office Basics, Inc	1/23/2024	Office Supplies	1/31/2024	\$	96.08	2/12/2024	182462
Office Supplies	Office Basics, Inc	1/24/2024	Office Supplies	1/31/2024	\$	20.32	2/12/2024	182462
Office Supplies	Office Basics, Inc	1/26/2024	Office Supplies	1/31/2024	\$	9.40	2/12/2024	182462
Office Supplies	Office Basics, Inc	1/30/2024	Office Supplies	1/31/2024	\$	18.30	2/12/2024	182462
Total 01400200202:					\$	305.97		
1400210102								
Postage Expense	FP Finance Program	12/27/2023	Postage Meter Lease	1/31/2024	\$	8.75	1/9/2024	182250
Postage Expense	FP Finance Program	1/29/2024	Postage Meter Lease	2/29/2024	\$	8.75	2/6/2024	182335
Total 01400210102:					\$	17.50		
1400210202								
Ordinance Book Updating	General Code	1/1/2024	Ordinance Book Updating	1/31/2024	\$	1,195.00	2/12/2024	182411
Ordinance Book Updating	General Code	1/31/2024	Ordinance Book Updating	1/31/2024	\$	1,155.00	2/12/2024	182411
Total 01400210202:					\$	2,350.00		
1400210602								
Advertising	21st Century Media-Philly Cluster	12/15/2023	Advertising	1/31/2024	\$	158.03	2/12/2024	182346
Advertising	21st Century Media-Philly Cluster	12/15/2023	Advertising	1/31/2024	\$	106.01	2/12/2024	182346
Advertising	21st Century Media-Philly Cluster	12/15/2023	Advertising	1/31/2024	\$	106.01	2/12/2024	182346
Advertising	21st Century Media-Philly Cluster	12/15/2023	Advertising	1/31/2024	\$	93.17	2/12/2024	182346
Advertising	21st Century Media-Philly Cluster	12/15/2023	Advertising	1/31/2024	\$	1,275.19	2/12/2024	182346
Advertising	21st Century Media-Philly Cluster	1/7/2024	Advertising	1/31/2024	\$	58.29	2/12/2024	182346
Advertising	21st Century Media-Philly Cluster	1/12/2024	Advertising	1/31/2024	\$	124.57	2/12/2024	182346
Advertising	21st Century Media-Philly Cluster	1/12/2024	Advertising	1/31/2024	\$	109.22	2/12/2024	182346
Advertising	21st Century Media-Philly Cluster	1/12/2024	Advertising	1/31/2024	\$	96.38	2/12/2024	182346
Total 01400210602:					\$	2,126.87		
1400260202								
Training	APMM	1/8/2024	APMM Executive Development Conference	1/31/2024	\$	400.00	1/16/2024	182261
Training	Pennsylvania State Assoc. of Boroughs	1/31/2024	Webinar - D Burman	2/29/2024	\$	30.00	2/6/2024	182340
Total 01400260202:					\$	430.00		
1400290202								
Legal Expenses	Kilkenny Law, LLC	1/2/2024	Legal Services - General	1/31/2024	\$	3,132.50	2/12/2024	182437
Total 01400290202:					\$	3,132.50		
1400290302								
Prof Services - Special	Kilkenny Law, LLC	1/2/2024	Legal Services - Tax Appeals	1/31/2024	\$	87.50	2/12/2024	182437
Prof Services - Special	Kilkenny Law, LLC	1/2/2024	Legal Services - General	1/31/2024	\$	503.75	2/12/2024	182437
Prof Services - Special	McNichol, Byrne, & Matlawski, PC	1/17/2024	Legal services - Veneer	1/31/2024	\$	17.50	2/12/2024	182451
Prof Services - Special	McNichol, Byrne, & Matlawski, PC	1/17/2024	Legal services - Steubner	1/31/2024	\$	472.50	2/12/2024	182451
Total 01400290302:					\$	1,081.25		
1400300002								
Communications	Comcast	1/2/2024	Cable Service - 1014 Darby Rd	1/31/2024	\$	198.76	1/16/2024	182266
Communications	Comcast Business	1/1/2024	Cable Service	1/31/2024	\$	45.58	1/16/2024	182268
Communications	Xtel Communications, Inc	1/1/2024	Phone Expense	1/31/2024	\$	20.73	1/16/2024	182293
Communications	AT & T Mobility	1/16/2024	Cellular Service	2/29/2024	\$	44.73	2/6/2024	182331
Total 01400300002:					\$	309.80		
1400400002								
Copier Lease/Maintenance	Toshiba America Business Solutions	12/25/2023	Copier Maintenance	1/31/2024	\$	15.50	1/9/2024	182258
Copier Lease/Maintenance	Toshiba Financial Service	12/28/2023	Copier Lease	1/31/2024	\$	51.46	1/9/2024	182259
Copier Lease/Maintenance	Toshiba Financial Service	1/23/2024	Copier Lease	1/31/2024	\$	51.46	1/30/2024	182326
Copier Lease/Maintenance	Toshiba America Business Solutions	1/22/2024	Copier Maintenance	2/29/2024	\$	9.00	2/6/2024	182344
Total 01400400002:					\$	127.42		
1400410602								
Public Officers/EPLI	Arthur J Gallagher Risk Mgmt Serv Inc	12/18/2023	P & C Insurance Premium â€" 3rd Installment	1/31/2024	\$	7,886.45	1/30/2024	182312
Total 01400410602:					\$	7,886.45		
1400411702								
Vehicle Insurance	Arthur J Gallagher Risk Mgmt Serv Inc	12/18/2023	P & C Insurance Premium â€" 3rd Installment	1/31/2024	\$	285.74	1/30/2024	182312

Tax Collection Fee	Tri-State Financial Group LLC	1/4/2024	Distribution of Tax Collection	1/31/2024	\$ 6,110.97	2/12/2024	182505
Total 01402450002:					\$ 6,110.97		
1406150002							
Life Insurance	North American Benefits Company	1/22/2024	Group Term Life Insurance	1/31/2024	\$ 26.40	1/30/2024	182320
Total 01406150002:					\$ 26.40		
1406150502							
Health Benefits	DelCo Public Schools Healthcare Trst	1/2/2024	Health Benefits	1/31/2024	\$ (8,199.50)	1/16/2024	182272
Total 01406150502:					\$ (8,199.50)		
1406151002							
Rx/Dental/Vision/LTD	North American Benefits Company	1/22/2024	Long Term Civilian Disability Insurance	2/29/2024	\$ 56.26	2/6/2024	182337
Total 01406151002:					\$ 56.26		
1406152002							
Workers Compensation	Arthur J Gallagher Risk Mgmt Serv Inc	1/8/2024	2022 WC Audit	1/31/2024	\$ 93.36	1/16/2024	182263
Total 01406152002:					\$ 93.36		
1406200202							
Office Supplies	Office Basics, Inc	1/2/2024	Office Supplies	1/31/2024	\$ 9.40	2/12/2024	182462
Office Supplies	Office Basics, Inc	1/24/2024	Office Supplies	1/31/2024	\$ 20.32	2/12/2024	182462
Office Supplies	Office Basics, Inc	1/26/2024	Office Supplies	1/31/2024	\$ 160.09	2/12/2024	182462
Office Supplies	Office Basics, Inc	1/26/2024	Office Supplies	1/31/2024	\$ 9.40	2/12/2024	182462
Office Supplies	Sir Speedy Printing Center #7099	1/18/2024	(595) Workers Comp Cards	1/31/2024	\$ 165.00	2/12/2024	182492
Office Supplies	Sir Speedy Printing Center #7099	1/26/2024	(150) Benefit Information Cards	1/31/2024	\$ 83.00	2/12/2024	182492
Total 01406200202:					\$ 447.21		
1406200502							
Computer Expense	PeopleGuru Inc	1/1/2024	Monthly Time & Attendance	1/31/2024	\$ 1,022.99	2/12/2024	182470
Computer Expense	PeopleGuru Inc	2/1/2024	Monthly Time & Attendance	1/31/2024	\$ 1,208.59	2/12/2024	182470
Total 01406200502:					\$ 2,231.58		
1406210102							
Postage Expense	FP Finance Program	12/27/2023	Postage Meter Lease	1/31/2024	\$ 6.25	1/9/2024	182250
Postage Expense	FP Finance Program	1/29/2024	Postage Meter Lease	2/29/2024	\$ 6.25	2/6/2024	182335
Total 01406210102:					\$ 12.50		
1406222702							
Admin Charge Prescriptions	Express Scripts Inc	1/2/2024	Prescription Benefits	1/31/2024	\$ 834.80	1/9/2024	421
Admin Charge Prescriptions	Express Scripts Inc	1/12/2024	Prescription Benefits	1/31/2024	\$ 3.00	1/12/2024	425
Admin Charge Prescriptions	Express Scripts Inc	1/22/2024	Prescription Benefits	1/31/2024	\$ 17.50	1/30/2024	429
Admin Charge Prescriptions	Express Scripts Inc	1/2/2024	Prescription Benefits	1/31/2024	\$ 834.80	1/9/2024	7093
Admin Charge Prescriptions	Express Scripts Inc	1/2/2024	Prescription Benefits	1/31/2024	\$ (834.80)	1/9/2024	7093
Total 01406222702:				855.3			
1406222802							
Admin Charge Vision Plan	Vision Benefits of America	1/5/2024	Vision Benefits	1/31/2024	\$ 85.88	1/23/2024	182309
Admin Charge Vision Plan	Vision Benefits of America	1/5/2024	Vision Benefits	1/31/2024	\$ 12.00	1/30/2024	182328
Total 01406222802:					\$ 97.88		
1406222902							
Admin - EAP	Health Advocate Solutions Inc	1/15/2024	Employee Assistance Program	1/31/2024	\$ 1,420.80	2/12/2024	182419
Total 01406222902:					\$ 1,420.80		
1406225102							
PA Unemployment Compensation	PA Dept of Labor & Industry	1/11/2024	4Q23 Unemployment Claims	1/31/2024	\$ 2,782.19	1/12/2024	424
Total 01406225102:					\$ 2,782.19		
1406300002							
Communications	Comcast Business	1/1/2024	Cable Service	1/31/2024	\$ 30.93	1/16/2024	182268
Communications	Xtel Communications, Inc	1/1/2024	Phone Expense	1/31/2024	\$ 14.07	1/16/2024	182293
Total 01406300002:					\$ 45.00		
1406310002							
Civilian Drug/Background Test	MLH Occupational & Travel Health	11/2/2023	Drug Test	1/31/2024	\$ 106.00	1/16/2024	182286
Civilian Drug/Background Test	MLH Occupational & Travel Health	1/2/2024	Drug Test	1/31/2024	\$ 106.00	1/16/2024	182286
Civilian Drug/Background Test	MLH Occupational & Travel Health	1/2/2024	Drug Test	1/31/2024	\$ 106.00	2/12/2024	182454
Total 01406310002:					\$ 318.00		
1406400002							
Copier Lease/Maintenance	Toshiba America Business Solutions	12/25/2023	Copier Maintenance	1/31/2024	\$ 15.50	1/9/2024	182258
Copier Lease/Maintenance	Toshiba Financial Service	12/28/2023	Copier Lease	1/31/2024	\$ 51.46	1/9/2024	182259

Copier Lease/Maintenance	Toshiba Financial Service	1/23/2024	Copier Lease	1/31/2024	\$	51.46	1/30/2024	182326
Copier Lease/Maintenance	Toshiba America Business Solutions	1/22/2024	Copier Maintenance	2/29/2024	\$	9.00	2/6/2024	182344
Total 01406400002:					\$	127.42		
1407150002								
Life Insurance	North American Benefits Company	1/22/2024	Group Term Life Insurance	1/31/2024	\$	66.00	1/30/2024	182320
Total 01407150002:					\$	66.00		
1407150502								
Health Benefits	DelCo Public Schools Healthcare Trst	1/2/2024	Health Benefits	1/31/2024	\$	7,778.61	1/16/2024	182272
Total 01407150502:					\$	7,778.61		
1407151002								
Rx/Dental/Vision/LTD	Express Scripts Inc	1/2/2024	Prescription Benefits	1/31/2024	\$	2.69	1/9/2024	422
Rx/Dental/Vision/LTD	Express Scripts Inc	1/12/2024	Prescription Benefits	1/31/2024	\$	2.25	1/12/2024	426
Rx/Dental/Vision/LTD	Express Scripts Inc	1/22/2024	Prescription Benefits	1/31/2024	\$	11.41	1/30/2024	430
Rx/Dental/Vision/LTD	Express Scripts Inc	1/2/2024	Prescription Benefits	1/31/2024	\$	2.69	1/9/2024	7092
Rx/Dental/Vision/LTD	Express Scripts Inc	1/2/2024	Prescription Benefits	1/31/2024	\$	(2.69)	1/9/2024	7092
Rx/Dental/Vision/LTD	North American Benefits Company	1/22/2024	Long Term Civilian Disability Insurance	2/29/2024	\$	106.04	2/6/2024	182337
Total 01407151002:					\$	122.39		
1407152002								
Workers Compensation	Arthur J Gallagher Risk Mgmt Serv Inc	1/8/2024	2022 WC Audit	1/31/2024	\$	210.06	1/16/2024	182263
Total 01407152002:					\$	210.06		
1407200502								
Computer Expense	Clearnetwork Inc	12/31/2023	Spam Management	1/31/2024	\$	225.06	2/12/2024	182381
Computer Expense	Clearnetwork Inc	1/31/2024	Spam Management	1/31/2024	\$	227.48	2/12/2024	182381
Total 01407200502:					\$	452.54		
1407300002								
Communications	Comcast Business	1/1/2024	Cable Service	1/31/2024	\$	61.86	1/16/2024	182268
Communications	Xtel Communications, Inc	1/1/2024	Phone Expense	1/31/2024	\$	28.14	1/16/2024	182293
Communications	AT & T Mobility	1/16/2024	Cellular Service	2/29/2024	\$	178.91	2/6/2024	182331
Total 01407300002:					\$	268.91		
1409150002								
Life Insurance	North American Benefits Company	1/22/2024	Group Term Life Insurance	1/31/2024	\$	53.40	1/30/2024	182320
Total 01409150002:					\$	53.40		
1409150502								
Health Benefits	DelCo Public Schools Healthcare Trst	1/2/2024	Health Benefits	1/31/2024	\$	6,352.61	1/16/2024	182272
Total 01409150502:					\$	6,352.61		
1409151002								
Rx/Dental/Vision/LTD	Express Scripts Inc	1/2/2024	Prescription Benefits	1/31/2024	\$	36.13	1/9/2024	422
Rx/Dental/Vision/LTD	Express Scripts Inc	1/12/2024	Prescription Benefits	1/31/2024	\$	2.61	1/12/2024	426
Rx/Dental/Vision/LTD	Express Scripts Inc	1/22/2024	Prescription Benefits	1/31/2024	\$	661.77	1/30/2024	430
Rx/Dental/Vision/LTD	Express Scripts Inc	1/2/2024	Prescription Benefits	1/31/2024	\$	36.13	1/9/2024	7092
Rx/Dental/Vision/LTD	Express Scripts Inc	1/2/2024	Prescription Benefits	1/31/2024	\$	(36.13)	1/9/2024	7092
Rx/Dental/Vision/LTD	North American Benefits Company	1/22/2024	Long Term Civilian Disability Insurance	2/29/2024	\$	122.30	2/6/2024	182337
Total 01409151002:					\$	822.81		
1409152002								
Workers Compensation	Arthur J Gallagher Risk Mgmt Serv Inc	1/8/2024	2022 WC Audit	1/31/2024	\$	233.40	1/16/2024	182263
Total 01409152002:					\$	233.40		
1409200002								
Miscellaneous	Flocco Inc	8/30/2023	Work Boots	1/31/2024	\$	325.00	1/16/2024	182275
Miscellaneous	Lowe's	12/6/2023	(3) Poinsettias	1/31/2024	\$	28.94	1/16/2024	182284
Miscellaneous	ReadyRefresh by Nestle Inc	1/6/2024	Water Service	1/31/2024	\$	150.46	1/23/2024	182306
Miscellaneous	Office Basics, Inc	12/27/2023	Break Room Supplies	1/31/2024	\$	27.67	2/12/2024	182462
Miscellaneous	Office Basics, Inc	1/3/2024	Break Room Supplies	1/31/2024	\$	98.60	2/12/2024	182462
Miscellaneous	Office Basics, Inc	1/19/2024	Kitchen Supplies	1/31/2024	\$	37.36	2/12/2024	182462
Miscellaneous	Office Basics, Inc	1/24/2024	Break Room Supplies	1/31/2024	\$	153.87	2/12/2024	182462
Miscellaneous	Office Basics, Inc	1/24/2024	Office Supplies	1/31/2024	\$	31.24	2/12/2024	182462
Total 01409200002:					\$	853.14		
1409201302								
Utilities	Aqua Pennsylvania	12/20/2023	50 Hilltop Rd - Water	1/31/2024	\$	94.81	1/9/2024	182244
Utilities	Peco Energy	12/28/2023	Allgates Rd Main - Gate Lght	1/31/2024	\$	36.03	1/9/2024	182256

Utilities	Peco Energy	12/28/2023	1010 Darby Rd	1/31/2024	\$	3,651.80	1/9/2024	182256
Utilities	Peco Energy	12/28/2023	1744 Burmont Rd	1/31/2024	\$	55.71	1/9/2024	182256
Utilities	Peco Energy	12/28/2023	1002 Darby Rd - Front	1/31/2024	\$	433.34	1/9/2024	182256
Utilities	Peco Energy	12/28/2023	3500 Darby Rd - Office	1/31/2024	\$	106.03	1/9/2024	182256
Utilities	Peco Energy	12/28/2023	2912 Normandy Rd	1/31/2024	\$	150.04	1/9/2024	182256
Utilities	Peco Energy	12/28/2023	Brookline Blvd Parking Lot	1/31/2024	\$	154.93	1/9/2024	182256
Utilities	Peco Energy	12/28/2023	101 Hilltop Rd	1/31/2024	\$	3,019.39	1/9/2024	182256
Utilities	Peco Energy	1/5/2024	Natural Gas - 1010 Darby Rd	1/31/2024	\$	1,204.82	1/16/2024	182288
Utilities	Aqua Pennsylvania	1/16/2024	1227 E Darby Rd - Brookline - Sprinkler	1/31/2024	\$	20.97	1/23/2024	182294
Utilities	Aqua Pennsylvania	1/16/2024	2231 E Darby Rd - Triangle Garden	1/31/2024	\$	78.29	1/23/2024	182294
Utilities	Aqua Pennsylvania	1/16/2024	1010 Darby Rd	1/31/2024	\$	329.87	1/23/2024	182294
Utilities	Aqua Pennsylvania	1/17/2024	2908 Normandy Rd	1/31/2024	\$	20.97	1/30/2024	182311
Utilities	Aqua Pennsylvania	1/23/2024	201 West Chester Pk - Llanerch	1/31/2024	\$	20.97	1/30/2024	182311
Utilities	Aqua Pennsylvania	1/22/2024	50 Hilltop Rd - Water	1/31/2024	\$	113.77	1/30/2024	182311
Utilities	Constellation NewEnergy Gas Division LLC	1/25/2024	Natural Gas - 1010 Darby Rd	1/31/2024	\$	1,324.81	1/30/2024	182315
Utilities	Constellation NewEnergy Gas Division LLC	1/25/2024	Natural Gas - 2325 Darby Rd	1/31/2024	\$	304.34	1/30/2024	182315
Utilities	Constellation NewEnergy Gas Division LLC	1/25/2024	Natural Gas - 2912 Normandy Rd	1/31/2024	\$	94.26	1/30/2024	182315
Utilities	Peco Energy	1/29/2024	Allgates Rd Main - Gate Lght	2/29/2024	\$	36.95	2/6/2024	182339
Utilities	Peco Energy	1/29/2024	1010 Darby Rd	2/29/2024	\$	3,775.50	2/6/2024	182339
Utilities	Peco Energy	1/29/2024	1744 Burmont Rd	2/29/2024	\$	55.70	2/6/2024	182339
Utilities	Peco Energy	1/29/2024	1002 Darby Rd - Front	2/29/2024	\$	434.78	2/6/2024	182339
Utilities	Peco Energy	1/29/2024	3500 Darby Rd - Office	2/29/2024	\$	127.33	2/6/2024	182339
Utilities	Peco Energy	1/29/2024	2912 Normandy Rd	2/29/2024	\$	215.30	2/6/2024	182339
Utilities	Peco Energy	1/29/2024	Brookline Blvd Parking Lot	2/29/2024	\$	170.24	2/6/2024	182339
Utilities	Peco Energy	1/29/2024	101 Hilltop Rd	2/29/2024	\$	3,867.17	2/6/2024	182339
Total 01409201302:					\$	19,898.12		
1409290302								
Professional Services	City Wide Facility Solutions	11/3/2023	Janitorial Services - Initial Clean	2/29/2024	\$	2,000.00	2/6/2024	182333
Professional Services	City Wide Facility Solutions	1/1/2024	Janitorial Services	1/31/2024	\$	1,881.10	2/12/2024	182380
Total 01409290302:					\$	3,881.10		
1409300002								
Communications	AT & T Mobility	1/16/2024	Cellular Service	2/29/2024	\$	134.18	2/6/2024	182331
Total 01409300002:					\$	134.18		
1409400802								
Repairs & Maintenance	Shred Patrol LLC	1/29/2024	Township Shredding	2/29/2024	\$	275.00	2/6/2024	182342
Repairs & Maintenance	Grainger	1/8/2024	25' Core Reel	1/31/2024	\$	590.44	2/12/2024	182413
Repairs & Maintenance	Nichols Plumbing & Heating, Inc	1/4/2024	Service - Heat (2325 Darby Rd)	1/31/2024	\$	200.00	2/12/2024	182458
Repairs & Maintenance	Sinclair Exterminating Inc	12/31/2023	Exterminating - Police/Admin, Public Works	1/31/2024	\$	360.00	2/12/2024	182491
Repairs & Maintenance	Tustin Energy Solutions, LLC	1/15/2024	Maintenance Agreement - 1010 Darby Rd	1/31/2024	\$	2,050.00	2/12/2024	182509
Repairs & Maintenance	Tustin Mechanical Services LLC	1/11/2024	Boiler Maintenance Kit	1/31/2024	\$	2,773.17	2/12/2024	182510
Total 01409400802:					\$	6,248.61		
1409401002								
Elevator Inspect/Maintenance	Superior Alarm Systems Inc	1/1/2024	Fire Alarm Monitoring - Elevator 911 System	1/31/2024	\$	75.00	2/12/2024	182498
Total 01409401002:					\$	75.00		
1409410902								
Property & Casualty Insurance	Arthur J Gallagher Risk Mgmt Serv Inc	12/18/2023	P & C Insurance Premium â€" 3rd Installment	1/31/2024	\$	36,377.23	1/30/2024	182312
Total 01409410902:					\$	36,377.23		
1409411702								
Vehicle Insurance	Arthur J Gallagher Risk Mgmt Serv Inc	12/18/2023	P & C Insurance Premium â€" 3rd Installment	1/31/2024	\$	857.21	1/30/2024	182312
Total 01409411702:					\$	857.21		
1409412802								
Alarm Maintenance	Superior Alarm Systems Inc	1/1/2024	Fire Alarm Monitoring - 1744 Burmont Rd	1/31/2024	\$	135.00	2/12/2024	182498
Alarm Maintenance	Superior Alarm Systems Inc	2/1/2024	Fire Alarm Monitoring - 2325 Darby Rd	1/31/2024	\$	135.00	2/12/2024	182498
Total 01409412802:					\$	270.00		
1409510002								
Vehicle Fuel	Petroleum Traders Corp	12/27/2023	Unleaded	1/31/2024	\$	123.72	2/12/2024	182473
Vehicle Fuel	Petroleum Traders Corp	1/19/2024	Unleaded	1/31/2024	\$	107.43	2/12/2024	182473
Total 01409510002:					\$	231.15		
1409600002								

Minor Equipment	Imperial Dade	9/15/2023	(2) Batteries, Clark Summit Pro 18sq	1/31/2024	\$ 2,552.64	1/30/2024	182318
Minor Equipment	Imperial Dade	9/29/2023	Back Pack Vacuum	1/31/2024	\$ 406.31	1/30/2024	182318
Minor Equipment	Imperial Dade	10/14/2022	RETURN - Floor Buffer Supplies	1/31/2024	\$ (559.72)	1/30/2024	182318
Total 01409600002:				2,399.23			
1410150002							
Life Insurance	North American Benefits Company	1/22/2024	Group Term Life Insurance	1/31/2024	\$ 61.80	1/30/2024	182320
Total 01410150002:					\$ 61.80		
1410150102							
Life Insurance - Police	North American Benefits Company	1/22/2024	Group Term Life Insurance	1/31/2024	\$ 1,293.75	1/30/2024	182320
Total 01410150102:					\$ 1,293.75		
1410150202							
Life Insurance - Ret'd Police	North American Benefits Company	1/22/2024	Group Term Life Insurance	1/31/2024	\$ 608.60	1/30/2024	182320
Total 01410150202:					\$ 608.60		
1410150502							
Health Benefits	DelCo Public Schools Healthcare Trst	1/2/2024	Health Benefits	1/31/2024	\$ 11,240.16	1/16/2024	182272
Total 01410150502:					\$ 11,240.16		
1410150602							
Health Benefits - Police	DelCo Public Schools Healthcare Trst	1/2/2024	Health Benefits	1/31/2024	\$ 129,182.20	1/16/2024	182272
Total 01410150602:					\$ 129,182.20		
1410150702							
Health Benefits - Ret'd Police	DelCo Public Schools Healthcare Trst	1/2/2024	Health Benefits	1/31/2024	\$ 48,973.81	1/16/2024	182272
Health Benefits - Ret'd Police	Independence Blue Cross	12/11/2023	Health Benefits	1/31/2024	\$ 4,321.80	1/16/2024	182276
Health Benefits - Ret'd Police	Independence Blue Cross	12/11/2023	Health Benefits	1/31/2024	\$ 5,868.27	1/16/2024	182277
Health Benefits - Ret'd Police	Independence Blue Cross	12/11/2023	Health Benefits	1/31/2024	\$ 1,658.22	1/16/2024	182278
Health Benefits - Ret'd Police	Independence Blue Cross	1/8/2024	Health Benefits	1/31/2024	\$ 5,868.27	1/16/2024	182279
Health Benefits - Ret'd Police	Independence Blue Cross	1/8/2024	Health Benefits	1/31/2024	\$ 4,561.90	1/16/2024	182280
Health Benefits - Ret'd Police	Independence Blue Cross	1/8/2024	Health Benefits	1/31/2024	\$ 1,658.22	1/16/2024	182281
Total 01410150702:					\$ 72,910.49		
1410151002							
Rx/Dental/Vision/LTD	Express Scripts Inc	1/2/2024	Prescription Benefits	1/31/2024	\$ 3,292.15	1/9/2024	422
Rx/Dental/Vision/LTD	Express Scripts Inc	1/12/2024	Prescription Benefits	1/31/2024	\$ 334.37	1/12/2024	426
Rx/Dental/Vision/LTD	Express Scripts Inc	1/22/2024	Prescription Benefits	1/31/2024	\$ 37.22	1/30/2024	430
Rx/Dental/Vision/LTD	Express Scripts Inc	1/2/2024	Prescription Benefits	1/31/2024	\$ 3,292.15	1/9/2024	7092
Rx/Dental/Vision/LTD	Express Scripts Inc	1/2/2024	Prescription Benefits	1/31/2024	\$ (3,292.15)	1/9/2024	7092
Rx/Dental/Vision/LTD	Vision Benefits of America	1/5/2024	Vision Benefits	1/31/2024	\$ 50.00	1/23/2024	182309
Rx/Dental/Vision/LTD	North American Benefits Company	1/22/2024	Long Term Civilian Disability Insurance	2/29/2024	\$ 133.92	2/6/2024	182337
Total 01410151002:					\$ 3,847.66		
1410151102							
Rx/Dental/Vision/LTD - Police	Express Scripts Inc	1/2/2024	Prescription Benefits	1/31/2024	\$ 8,336.01	1/9/2024	422
Rx/Dental/Vision/LTD - Police	Express Scripts Inc	1/12/2024	Prescription Benefits	1/31/2024	\$ 442.60	1/12/2024	426
Rx/Dental/Vision/LTD - Police	Express Scripts Inc	1/22/2024	Prescription Benefits	1/31/2024	\$ 7,972.49	1/30/2024	430
Rx/Dental/Vision/LTD - Police	Express Scripts Inc	1/2/2024	Prescription Benefits	1/31/2024	\$ 8,336.01	1/9/2024	7092
Rx/Dental/Vision/LTD - Police	Express Scripts Inc	1/2/2024	Prescription Benefits	1/31/2024	\$ (8,336.01)	1/9/2024	7092
Rx/Dental/Vision/LTD - Police	Vision Benefits of America	1/5/2024	Vision Benefits	1/31/2024	\$ 100.00	1/30/2024	182328
Total 01410151102:					\$ 16,851.10		
1410151202							
Rx/Dent'l/Vision - Retd Police	Express Scripts Inc	1/2/2024	Prescription Benefits	1/31/2024	\$ 83.01	1/9/2024	422
Rx/Dent'l/Vision - Retd Police	Express Scripts Inc	1/2/2024	Prescription Benefits	1/31/2024	\$ 11,043.89	1/9/2024	422
Rx/Dent'l/Vision - Retd Police	Express Scripts Inc	1/2/2024	Prescription Benefits	1/31/2024	\$ 5,280.54	1/9/2024	422
Rx/Dent'l/Vision - Retd Police	Express Scripts Inc	1/12/2024	Prescription Benefits	1/31/2024	\$ 149.42	1/12/2024	426
Rx/Dent'l/Vision - Retd Police	Express Scripts Inc	1/12/2024	Prescription Benefits	1/31/2024	\$ 16,510.10	1/12/2024	426
Rx/Dent'l/Vision - Retd Police	Express Scripts Inc	1/12/2024	Prescription Benefits	1/31/2024	\$ 20,138.55	1/12/2024	426
Rx/Dent'l/Vision - Retd Police	Express Scripts Inc	1/22/2024	Prescription Benefits	1/31/2024	\$ 200.87	1/30/2024	430
Rx/Dent'l/Vision - Retd Police	Express Scripts Inc	1/22/2024	Prescription Benefits	1/31/2024	\$ 8,315.12	1/30/2024	430
Rx/Dent'l/Vision - Retd Police	Express Scripts Inc	1/22/2024	Prescription Benefits	1/31/2024	\$ 4,350.27	1/30/2024	430
Rx/Dent'l/Vision - Retd Police	Express Scripts Inc	1/2/2024	Prescription Benefits	1/31/2024	\$ 83.01	1/9/2024	7092
Rx/Dent'l/Vision - Retd Police	Express Scripts Inc	1/2/2024	Prescription Benefits	1/31/2024	\$ 11,043.89	1/9/2024	7092
Rx/Dent'l/Vision - Retd Police	Express Scripts Inc	1/2/2024	Prescription Benefits	1/31/2024	\$ 5,280.54	1/9/2024	7092
Rx/Dent'l/Vision - Retd Police	Express Scripts Inc	1/2/2024	Prescription Benefits	1/31/2024	\$ (83.01)	1/9/2024	7092

Rx/Dent/IVision - Retd Police	Express Scripts Inc	1/2/2024	Prescription Benefits	1/31/2024	\$	(11,043.89)	1/9/2024	7092
Rx/Dent/IVision - Retd Police	Express Scripts Inc	1/2/2024	Prescription Benefits	1/31/2024	\$	(5,280.54)	1/9/2024	7092
Rx/Dent/IVision - Retd Police	Vision Benefits of America	1/5/2024	Vision Benefits	1/31/2024	\$	268.00	1/23/2024	182309
Total 01410151202:					\$	66,339.77		
1410152002								
Workers Compensation	Arthur J Gallagher Risk Mgmt Serv Inc	1/8/2024	2022 WC Audit	1/31/2024	\$	5,508.24	1/16/2024	182263
Workers Compensation	Arthur J Gallagher Risk Mgmt Serv Inc	1/8/2024	Heart & Lung	1/31/2024	\$	14,442.00	1/16/2024	182263
Total 01410152002:					\$	19,950.24		
1410152502								
Death Service Benefits	Gail Stickney	2/1/2024	Death Service Benefits	1/31/2024	\$	157.26	2/12/2024	182409
Total 01410152502:					\$	157.26		
1410200002								
Miscellaneous Expense	ReadyRefresh by Nestle Inc	1/6/2024	Water Service	1/31/2024	\$	150.45	1/23/2024	182306
Miscellaneous Expense	Petty Cash - Haverford Township	1/31/2024	Petty Cash - Police	2/29/2024	\$	67.28	2/6/2024	182341
Miscellaneous Expense	R.S. Sales & Service, Inc	1/31/2024	Service - Ice Machine	1/31/2024	\$	576.00	2/12/2024	182481
Miscellaneous Expense	St Jude Shop Inc	1/2/2024	St Joseph Personal Size	1/31/2024	\$	43.00	2/12/2024	182495
Miscellaneous Expense	ULINE, Inc	12/18/2023	(2) Cotton Coveralls	1/31/2024	\$	105.37	2/12/2024	182512
Total 01410200002:					\$	942.10		
1410200202								
Office Supplies	Office Basics, Inc	11/20/2023	Office Supplies	1/31/2024	\$	329.94	1/23/2024	182304
Office Supplies	Office Basics, Inc	1/10/2024	RETURN - (6) Ink Cartridges	1/31/2024	\$	(341.46)	2/12/2024	182462
Office Supplies	Office Basics, Inc	1/3/2024	Office Supplies	1/31/2024	\$	350.43	2/12/2024	182462
Office Supplies	Office Basics, Inc	1/9/2024	Office Supplies	1/31/2024	\$	682.92	2/12/2024	182462
Office Supplies	Office Basics, Inc	1/10/2024	Office Supplies	1/31/2024	\$	316.62	2/12/2024	182462
Office Supplies	Office Basics, Inc	1/11/2024	Office Supplies	1/31/2024	\$	64.47	2/12/2024	182462
Office Supplies	Office Basics, Inc	1/12/2024	Office Supplies	1/31/2024	\$	83.96	2/12/2024	182462
Office Supplies	Office Basics, Inc	1/29/2024	Office Supplies	1/31/2024	\$	112.06	2/12/2024	182462
Office Supplies	Schwaab Inc	1/4/2024	Flash Stamp	1/31/2024	\$	52.50	2/12/2024	182489
Office Supplies	Schwaab Inc	1/10/2024	2024 Self-Inking Date Stamp	1/31/2024	\$	170.49	2/12/2024	182489
Total 01410200202:					\$	1,821.93		
1410200302								
Office Equip & Furniture	Deborah Tori	1/6/2024	Reimb - Prisoner Property Bags	1/31/2024	\$	56.62	1/16/2024	182270
Total 01410200302:					\$	56.62		
1410210102								
Postage Expense	FP Finance Program	12/27/2023	Postage Meter Lease	1/31/2024	\$	18.75	1/9/2024	182250
Postage Expense	Federal Express Corp	1/23/2024	Express Mail	2/29/2024	\$	52.15	2/6/2024	182334
Postage Expense	FP Finance Program	1/29/2024	Postage Meter Lease	2/29/2024	\$	18.75	2/6/2024	182335
Total 01410210102:					\$	89.65		
1410260002								
Assoc Dues & Membership	FBI-LEEDA	1/1/2024	FBI LEEDA Membership - J Kelly	1/31/2024	\$	50.00	2/12/2024	182403
Assoc Dues & Membership	FBI-LEEDA	1/1/2024	FBI LEEDA Membership - E Dolan	1/31/2024	\$	50.00	2/12/2024	182403
Assoc Dues & Membership	IACP	12/20/2023	Membership - E Dolan	1/31/2024	\$	190.00	2/12/2024	182425
Assoc Dues & Membership	IACP	12/20/2023	Membership - J Viola	1/31/2024	\$	190.00	2/12/2024	182425
Assoc Dues & Membership	IACP	12/20/2023	Membership - S Bedrossian	1/31/2024	\$	190.00	2/12/2024	182425
Assoc Dues & Membership	IACP	12/20/2023	Membership - J Hagan	1/31/2024	\$	190.00	2/12/2024	182425
Assoc Dues & Membership	IACP	12/20/2023	Membership - T Long	1/31/2024	\$	190.00	2/12/2024	182425
Assoc Dues & Membership	National Tactical Officers Association	1/16/2024	Membership Renewal - C Scott #96175	1/31/2024	\$	35.00	2/12/2024	182457
Assoc Dues & Membership	Police Chiefs Assoc. of Southeastern Pa	1/25/2024	2024 Membership Dues - J Viola	1/31/2024	\$	75.00	2/12/2024	182477
Total 01410260002:					\$	1,160.00		
1410260102								
Publications & Subscriptions	Thomson Reuters-West	1/1/2024	Information Charges	1/31/2024	\$	316.33	2/12/2024	182502
Total 01410260102:					\$	316.33		
1410260202								
Training	Delaware Cty Police Chief's Association	1/5/2024	DCPCA Installation Banquet	1/31/2024	\$	375.00	1/9/2024	182249
Training	Delaware County Fraternal Order of	1/5/2024	Award and Retirement Dinner	1/31/2024	\$	180.00	1/16/2024	182271
Training	Delaware County Fraternal Order of	1/5/2024	Award and Retirement Dinner	1/31/2024	\$	(180.00)	1/22/2024	182271
Training	Baltimore County Police Foundation Inc	1/23/2024	Training - SBedrossian, TLong, AHughes, THowe	1/31/2024	\$	1,100.00	2/12/2024	182363
Training	CooperUniversity Physicians	1/30/2024	Training - S Lane, L Howard	1/31/2024	\$	350.00	2/12/2024	182383
Training	PA Chiefs of Police Association	1/11/2024	Training - S Bedrossian	1/31/2024	\$	150.00	2/12/2024	182465

Training	PA Chiefs of Police Association	1/11/2024	Training - G Dolan	1/31/2024	\$	150.00	2/12/2024	182465
Training	Personal Protection Consultants inc	1/24/2024	Training - SLane, MDeSanctis	1/31/2024	\$	1,794.00	2/12/2024	182471
Total 01410260202:					\$	3,919.00		
1410280302								
Uniforms	911 Safety Equipment LLC	1/30/2024	Uniforms	1/31/2024	\$	150.00	2/12/2024	182347
Uniforms	Atlantic Tactical	1/4/2024	Uniform	1/31/2024	\$	41.99	2/12/2024	182362
Uniforms	Emblem Enterprises, Inc	1/24/2024	Uniforms	1/31/2024	\$	2,685.01	2/12/2024	182402
Uniforms	Witmer Public Safety Group Inc	1/2/2024	Uniforms	1/31/2024	\$	16.00	2/12/2024	182517
Uniforms	Witmer Public Safety Group Inc	1/2/2024	Uniforms	1/31/2024	\$	108.00	2/12/2024	182517
Uniforms	Witmer Public Safety Group Inc	1/2/2024	Uniforms	1/31/2024	\$	138.00	2/12/2024	182517
Uniforms	Witmer Public Safety Group Inc	1/2/2024	Uniforms	1/31/2024	\$	33.00	2/12/2024	182517
Uniforms	Witmer Public Safety Group Inc	1/2/2024	Uniforms	1/31/2024	\$	26.00	2/12/2024	182517
Uniforms	Witmer Public Safety Group Inc	1/2/2024	Uniforms	1/31/2024	\$	61.00	2/12/2024	182517
Uniforms	Witmer Public Safety Group Inc	1/12/2024	Uniforms	1/31/2024	\$	25.00	2/12/2024	182517
Uniforms	Witmer Public Safety Group Inc	1/23/2024	Uniforms	1/31/2024	\$	138.00	2/12/2024	182517
Total 01410280302:					\$	3,422.00		
1410280702								
Uniform Maintenance	Manoa Cleaners, Inc	12/16/2023	Uniform cleaning	1/31/2024	\$	946.35	2/12/2024	182445
Total 01410280702:					\$	946.35		
1410300002								
Communications	Comcast Business	1/1/2024	Cable Service	1/31/2024	\$	1,162.40	1/16/2024	182268
Communications	Xtel Communications, Inc	1/1/2024	Phone Expense	1/31/2024	\$	528.71	1/16/2024	182293
Communications	Comcast	1/12/2024	Cable Service - 1010 Darby Rd	1/31/2024	\$	153.66	1/23/2024	182298
Communications	AT & T Mobility	1/16/2024	Cellular Service	2/29/2024	\$	2,907.33	2/6/2024	182331
Total 01410300002:					\$	4,752.10		
1410300102								
Radio Rent/Maintenance	Eagle Wireless Communications LLC	1/15/2024	Geotab Monthly Service - Police	1/31/2024	\$	568.62	2/12/2024	182397
Total 01410300102:					\$	568.62		
1410400002								
Copier Lease/Maintenance	Toshiba America Business Solutions	12/25/2023	Copier Maintenance	1/31/2024	\$	153.39	1/9/2024	182258
Copier Lease/Maintenance	Toshiba Financial Service	12/28/2023	Copier Lease	1/31/2024	\$	549.11	1/9/2024	182259
Copier Lease/Maintenance	Toshiba Financial Service	1/23/2024	Copier Lease	1/31/2024	\$	549.11	1/30/2024	182326
Copier Lease/Maintenance	Toshiba America Business Solutions	1/22/2024	Copier Maintenance	2/29/2024	\$	118.74	2/6/2024	182344
Total 01410400002:					\$	1,370.35		
1410411702								
Vehicle Insurance	Arthur J Gallagher Risk Mgmt Serv Inc	12/18/2023	P & C Insurance Premium â€“ 3rd Installment	1/31/2024	\$	18,458.68	1/30/2024	182312
Total 01410411702:					\$	18,458.68		
1410412402								
Police Professional Insurance	Arthur J Gallagher Risk Mgmt Serv Inc	12/18/2023	P & C Insurance Premium â€“ 3rd Installment	1/31/2024	\$	14,737.45	1/30/2024	182312
Total 01410412402:					\$	14,737.45		
1410510002								
Vehicle Fuel	PA DEP	12/5/2023	Storage Tank Permit - 1014 Darby Rd	1/31/2024	\$	50.00	1/30/2024	182321
Vehicle Fuel	Petroleum Traders Corp	12/27/2023	Unleaded	1/31/2024	\$	7,576.44	2/12/2024	182473
Vehicle Fuel	Petroleum Traders Corp	1/19/2024	Unleaded	1/31/2024	\$	8,189.08	2/12/2024	182473
Vehicle Fuel	School District of Haverford Township	1/29/2024	Diesel Fuel	1/31/2024	\$	81.90	2/12/2024	182488
Total 01410510002:					\$	15,897.42		
1410510702								
Vehicle Maintenance	Ardmore Tire Inc	12/20/2023	(16) Tires C-10, 12, 16, 18	1/31/2024	\$	2,280.16	2/12/2024	182359
Vehicle Maintenance	Berrodin Parts Warehouse	1/9/2024	(3) Coils, (20) Bulbs C-42	1/31/2024	\$	222.82	2/12/2024	182364
Vehicle Maintenance	Berrodin Parts Warehouse	1/9/2024	(4) Capsules C-31	1/31/2024	\$	15.84	2/12/2024	182364
Vehicle Maintenance	Berrodin Parts Warehouse	1/9/2024	Sensor C-12	1/31/2024	\$	44.14	2/12/2024	182364
Vehicle Maintenance	Berrodin Parts Warehouse	1/17/2024	Housing C-16	1/31/2024	\$	48.50	2/12/2024	182364
Vehicle Maintenance	Berrodin Parts Warehouse	1/18/2024	Temp Sensor C-16	1/31/2024	\$	17.09	2/12/2024	182364
Vehicle Maintenance	Berrodin Parts Warehouse	1/26/2024	Temp Sensor C-21	1/31/2024	\$	17.09	2/12/2024	182364
Vehicle Maintenance	Church's Auto Parts	1/17/2024	Battery, Core C-31	1/31/2024	\$	214.05	2/12/2024	182379
Vehicle Maintenance	Church's Auto Parts	1/18/2024	RETURN - Core	1/31/2024	\$	(9.00)	2/12/2024	182379
Vehicle Maintenance	Havis Inc	12/21/2022	iPad	1/31/2024	\$	829.76	2/12/2024	182418
Vehicle Maintenance	Hill Buick GMC	1/5/2024	Pump C-21	1/31/2024	\$	384.96	2/12/2024	182420
Vehicle Maintenance	Hill Buick GMC	12/14/2023	Sensor, Connector and Motor, C-12, 25	1/31/2024	\$	143.04	2/12/2024	182420

Vehicle Maintenance	Hill Buick GMC	12/11/2023	Link C-28	1/31/2024	\$ 59.99	2/12/2024	182420
Vehicle Maintenance	Hill Buick GMC	12/22/2023	(3) Pad Kits C-14, 16, 22	1/31/2024	\$ 371.25	2/12/2024	182420
Vehicle Maintenance	Hill Buick GMC	12/14/2023	2 Pad Kits, C-41,15	1/31/2024	\$ 153.69	2/12/2024	182420
Vehicle Maintenance	Hill Buick GMC	12/18/2023	Arm C-16	1/31/2024	\$ 194.43	2/12/2024	182420
Vehicle Maintenance	Hill Buick GMC	1/22/2024	Lamp, C-2	1/31/2024	\$ 471.08	2/12/2024	182420
Vehicle Maintenance	Hill Buick GMC	12/27/2023	Pump, Belt, Belt Kit C-14	1/31/2024	\$ 364.85	2/12/2024	182420
Vehicle Maintenance	Hill Buick GMC	12/22/2023	Module C-15	1/31/2024	\$ 121.42	2/12/2024	182420
Vehicle Maintenance	Hill Buick GMC	12/28/2023	94R-AGM, (6) Nut, Clamp, Hose	1/31/2024	\$ 509.65	2/12/2024	182420
Vehicle Maintenance	Hill Buick GMC	1/4/2024	(12) Filters C-12, 14, 17, 19, 24, 35	1/31/2024	\$ 87.60	2/12/2024	182420
Vehicle Maintenance	Hill Buick GMC	1/8/2024	(2) Sensors C-21	1/31/2024	\$ 125.60	2/12/2024	182420
Vehicle Maintenance	Hill Buick GMC	1/12/2024	(2) Relays C-16, 27, 29	1/31/2024	\$ 248.64	2/12/2024	182420
Vehicle Maintenance	Hill Buick GMC	1/15/2024	Reman Eng, Core C-25	1/31/2024	\$ 11,111.00	2/12/2024	182420
Vehicle Maintenance	Hill Buick GMC	1/24/2024	(12) Filters C-1, 2,4 ,10,11, 28	1/31/2024	\$ 87.60	2/12/2024	182420
Vehicle Maintenance	Hill Buick GMC	1/26/2024	Tank C-11	1/31/2024	\$ 33.27	2/12/2024	182420
Vehicle Maintenance	Hill Buick GMC	1/26/2024	RETURN - Core	1/31/2024	\$ (5,000.00)	2/12/2024	182420
Vehicle Maintenance	Joe's Automotive	12/20/2023	Alignment - C-16	1/31/2024	\$ 120.00	2/12/2024	182431
Vehicle Maintenance	McLenaghan Wholesale Tires Inc	1/11/2024	(7) Tires C-4, 23	1/31/2024	\$ 1,391.00	2/12/2024	182450
Vehicle Maintenance	Pacifico Marple Ford	1/4/2024	(2) Blades, (6) Filter C-6, 7, 20	1/31/2024	\$ 134.64	2/12/2024	182466
Vehicle Maintenance	Pacifico Marple Ford	1/5/2024	Tube C-44	1/31/2024	\$ 26.50	2/12/2024	182466
Vehicle Maintenance	Park's Best Car Wash Inc	1/2/2024	Car Washes	1/31/2024	\$ 442.50	2/12/2024	182467
Vehicle Maintenance	TruckPro LLC Corp	12/20/2023	(2) Batteries, C-27	1/31/2024	\$ 332.16	2/12/2024	182507
Vehicle Maintenance	TruckPro LLC Corp	1/16/2024	(2) Batteries C-26, 41	1/31/2024	\$ 341.50	2/12/2024	182507
Vehicle Maintenance	YCG Inc	1/29/2024	ENRADD Calibrations	1/31/2024	\$ 3,341.75	2/12/2024	182518
Total 01410510702:					\$ 19,278.57		
1410600002							
Minor Equipment	Qualification Targets Inc	1/25/2024	(350) Silhouette Targets	1/31/2024	\$ 450.84	2/12/2024	182480
Minor Equipment	Tedder Industries LLC	1/22/2024	(8) Holsters, (8) Rapid Force Belts	1/31/2024	\$ 863.55	2/12/2024	182501
Minor Equipment	Witmer Public Safety Group Inc	1/11/2024	(5) Air Respirator Kits	1/31/2024	\$ 3,683.11	2/12/2024	182517
Total 01410600002:					\$ 4,997.50		
1410610302							
Weapons/Ammunition/Range	MMJM Enterprises LLC	1/4/2024	Ammunition	1/31/2024	\$ 231.40	2/12/2024	182455
Weapons/Ammunition/Range	MMJM Enterprises LLC	1/24/2024	Ammunition	1/31/2024	\$ 958.20	2/12/2024	182455
Total 01410610302:					\$ 1,189.60		
1410610802							
Drug Testing	Drugscan, Inc	12/21/2023	Drug testing	1/31/2024	\$ 705.00	2/12/2024	182395
Total 01410610802:					\$ 705.00		
1410611502							
Auto Purchase Expense	Havis Inc	9/25/2023	Outfit C-19	1/31/2024	\$ 20,213.67	2/12/2024	182418
Auto Purchase Expense	Havis Inc	10/20/2023	Outfit C-17	1/31/2024	\$ 19,445.67	2/12/2024	182418
Total 01410611502:					\$ 39,659.34		
1410612202							
Printing Expenses	Nuss Printing Inc	1/17/2024	Business Cards - MHufnal, SRost, CHines	1/31/2024	\$ 173.50	2/12/2024	182461
Total 01410612202:					\$ 173.50		
1410612502							
Live Scan Maintenance	All Traffic Solutions, Inc.	1/4/2024	Traffic App Suite (12 mos)	1/31/2024	\$ 5,500.00	2/12/2024	182353
Total 01410612502:					\$ 5,500.00		
1410614102							
Canine Development	PetSmart #1804	1/17/2024	K9 Supplies - Axel	1/31/2024	\$ 155.97	2/12/2024	182474
Canine Development	Tri County Canine, LLC	1/12/2024	Seminar - TMcDermott, LMLaughlin	1/31/2024	\$ 150.00	2/12/2024	182503
Canine Development	VCA Wellington Animal Hospital	12/10/2023	Boarding - Bodhi	1/31/2024	\$ 357.30	2/12/2024	182513
Total 01410614102:					\$ 663.27		
1410614202							
Community Service	Human Relations Media	1/10/2024	(3) Training DVD's	1/31/2024	\$ 481.43	2/12/2024	182424
Total 01410614202:					\$ 481.43		
1411201602							
Hydrant Rentals	Aqua Pennsylvania	12/20/2023	50 Hilltop Rd - Hydrant	1/31/2024	\$ 62.26	1/9/2024	182244
Hydrant Rentals	Aqua Pennsylvania	1/2/2024	(519) Hydrants - 2325 Darby Rd	1/31/2024	\$ 44,385.63	1/16/2024	182262
Hydrant Rentals	Aqua Pennsylvania	1/2/2024	(2) Hydrants - 120 Allgates Dr	1/31/2024	\$ 207.24	1/16/2024	182262
Hydrant Rentals	Aqua Pennsylvania	1/2/2024	(25) Hydrants - 2325 Darby Rd	1/31/2024	\$ 2,138.04	1/16/2024	182262

Hydrant Rentals	Aqua Pennsylvania	1/16/2024	1010 Darby Rd - Hydrant	1/31/2024	\$	248.86	1/23/2024	182294
Hydrant Rentals	Aqua Pennsylvania	1/17/2024	1 Allgates Dr - Hydrant	1/31/2024	\$	20.97	1/30/2024	182311
Hydrant Rentals	Aqua Pennsylvania	1/17/2024	900 Parkview Dr - Hydrant	1/31/2024	\$	112.98	1/30/2024	182311
Hydrant Rentals	Aqua Pennsylvania	1/22/2024	50 Hilltop Rd - Hydrant	1/31/2024	\$	41.62	1/30/2024	182311
Total 01411201602:					\$	47,217.60		
1411260302								
Recruitment & Retention	Robert Sandy	12/27/2023	Act 172 (2023 Refund)	1/31/2024	\$	254.41	1/9/2024	182257
Recruitment & Retention	Andrew Payne	1/22/2024	Reimb - HTBF Awards	2/29/2024	\$	45.00	2/6/2024	182329
Recruitment & Retention	Park's Best Car Wash Inc	1/2/2024	Car Washes	1/31/2024	\$	52.50	2/12/2024	182467
Total 01411260302:					\$	351.91		
1411300002								
Communications	Oakmont Fire Company	1/5/2024	Reimb - Active 911	1/31/2024	\$	742.50	1/16/2024	182287
Total 01411300002:					\$	742.50		
1411411902								
Fire Truck Insurance	Arthur J Gallagher Risk Mgmt Serv Inc	12/18/2023	P & C Insurance Premium a€" 3rd Installment	1/31/2024	\$	4,628.95	1/30/2024	182312
Total 01411411902:					\$	4,628.95		
1411510002								
Vehicle Fuel	Petroleum Traders Corp	12/27/2023	Unleaded	1/31/2024	\$	314.93	2/12/2024	182473
Vehicle Fuel	Petroleum Traders Corp	1/19/2024	Unleaded	1/31/2024	\$	273.47	2/12/2024	182473
Vehicle Fuel	School District of Haverford Township	1/29/2024	Diesel Fuel	1/31/2024	\$	1,493.51	2/12/2024	182488
Total 01411510002:					\$	2,081.91		
1411510702								
Vehicle Maintenance	Del-Val International Trucks, Inc	1/2/2024	Turbo Charge Actuator, Turbo Charge Actuator Core E-56	1/31/2024	\$	1,800.98	2/12/2024	182392
Total 01411510702:					\$	1,800.98		
1412150002								
Life Insurance	North American Benefits Company	1/22/2024	Group Term Life Insurance	1/31/2024	\$	37.80	1/30/2024	182320
Total 01412150002:					\$	37.80		
1412150502								
Health Benefits	DelCo Public Schools Healthcare Trst	1/2/2024	Health Benefits	1/31/2024	\$	4,213.64	1/16/2024	182272
Total 01412150502:					\$	4,213.64		
1412151002								
Rx/Dental/Vision/LTD	Express Scripts Inc	1/2/2024	Prescription Benefits	1/31/2024	\$	27.44	1/9/2024	422
Rx/Dental/Vision/LTD	Express Scripts Inc	1/12/2024	Prescription Benefits	1/31/2024	\$	(3.18)	1/12/2024	426
Rx/Dental/Vision/LTD	Express Scripts Inc	1/22/2024	Prescription Benefits	1/31/2024	\$	176.86	1/30/2024	430
Rx/Dental/Vision/LTD	Express Scripts Inc	1/2/2024	Prescription Benefits	1/31/2024	\$	27.44	1/9/2024	7092
Rx/Dental/Vision/LTD	Express Scripts Inc	1/2/2024	Prescription Benefits	1/31/2024	\$	(27.44)	1/9/2024	7092
Rx/Dental/Vision/LTD	North American Benefits Company	1/22/2024	Long Term Civilian Disability Insurance	2/29/2024	\$	80.77	2/6/2024	182337
Total 01412151002:					\$	281.89		
1412152002								
Workers Compensation	Arthur J Gallagher Risk Mgmt Serv Inc	1/8/2024	2022 WC Audit	1/31/2024	\$	140.04	1/16/2024	182263
Total 01412152002:					\$	140.04		
1412200002								
Miscellaneous Expense	James McCans	12/28/2023	Reimb. - Miscellaneous	1/31/2024	\$	417.81	1/9/2024	182252
Total 01412200002:					\$	417.81		
1412200202								
Office Supplies	Office Basics, Inc	1/2/2024	Office Supplies	1/31/2024	\$	9.40	2/12/2024	182462
Office Supplies	Office Basics, Inc	1/26/2024	Office Supplies	1/31/2024	\$	9.40	2/12/2024	182462
Total 01412200202:					\$	18.80		
1412200402								
Medical Supplies	Bound Tree Medical LLC	10/18/2023	RETURN - (4) Batteries	1/31/2024	\$	(168.76)	2/12/2024	182368
Medical Supplies	Bound Tree Medical LLC	11/8/2023	Medical Supplies	1/31/2024	\$	29.89	2/12/2024	182368
Total 01412200402:					\$	(138.87)		
1412201302								
Utilities	Peco Energy	12/28/2023	2325 Darby Rd - Quatrani Bld	1/31/2024	\$	202.47	1/9/2024	182256
Utilities	Peco Energy	12/28/2023	800 Ardmore Ave	1/31/2024	\$	483.89	1/9/2024	182256
Utilities	Aqua Pennsylvania	1/16/2024	2325 Darby Rd	1/31/2024	\$	49.63	1/23/2024	182294
Utilities	Peco Energy	1/29/2024	2325 Darby Rd - Quatrani Bld	2/29/2024	\$	198.84	2/6/2024	182339
Utilities	Peco Energy	1/29/2024	800 Ardmore Ave	2/29/2024	\$	765.74	2/6/2024	182339
Total 01412201302:					\$	1,700.57		

1412280302								
Uniform Regular	James McCans	12/30/2023	Reimb - Uniform Pants	1/31/2024	\$	75.98	1/9/2024	182252
Total 01412280302:					\$	75.98		
1412290302								
Professional Services	Sinclair Exterminating Inc	12/31/2023	Exterminating - EMS	1/31/2024	\$	135.00	2/12/2024	182491
Total 01412290302:					\$	135.00		
1412300002								
Communications	Comcast	1/6/2024	Cable Service - 800 Ardmore Ave	1/31/2024	\$	383.27	1/16/2024	182267
Communications	Comcast Business	1/1/2024	Cable Service	1/31/2024	\$	14.65	1/16/2024	182268
Communications	Xtel Communications, Inc	1/1/2024	Phone Expense	1/31/2024	\$	6.66	1/16/2024	182293
Communications	Comcast	1/23/2024	Cable Service - 2325 Darby Rd	1/31/2024	\$	321.92	1/30/2024	182314
Communications	AT & T Mobility	1/16/2024	Cellular Service	2/29/2024	\$	357.83	2/6/2024	182331
Total 01412300002:					\$	1,084.33		
1412411702								
Vehicle Insurance	Arthur J Gallagher Risk Mgmt Serv Inc	12/18/2023	P & C Insurance Premium a€" 3rd Installment	1/31/2024	\$	2,285.90	1/30/2024	182312
Total 01412411702:					\$	2,285.90		
1412510002								
Vehicle Fuel	Petroleum Traders Corp	12/27/2023	Unleaded	1/31/2024	\$	248.80	2/12/2024	182473
Vehicle Fuel	Petroleum Traders Corp	1/19/2024	Unleaded	1/31/2024	\$	268.92	2/12/2024	182473
Vehicle Fuel	School District of Haverford Township	1/29/2024	Diesel Fuel	1/31/2024	\$	3,070.48	2/12/2024	182488
Total 01412510002:					\$	3,588.20		
1412510702								
Vehicle Maintenance	Church's Auto Parts	1/23/2024	(2) Tie Rods, Magnum Steer 108-7	1/31/2024	\$	221.71	2/12/2024	182379
Vehicle Maintenance	Mickey's Suburban Alignment Inc	1/24/2024	Alignment 108-7	1/31/2024	\$	157.50	2/12/2024	182453
Vehicle Maintenance	Pacifico Marple Ford	12/22/2023	Starter MSPO 108-7A	1/31/2024	\$	965.56	2/12/2024	182466
Vehicle Maintenance	Pacifico Marple Ford	1/9/2024	Hose Raspo, Pump Asy, Thermostat 108-7A	1/31/2024	\$	822.88	2/12/2024	182466
Vehicle Maintenance	Pacifico Marple Ford	1/8/2024	Pump Asy 108-7A	1/31/2024	\$	286.50	2/12/2024	182466
Vehicle Maintenance	Pacifico Marple Ford	1/9/2024	Hose 108-7A	1/31/2024	\$	38.75	2/12/2024	182466
Vehicle Maintenance	Pacifico Marple Ford	1/22/2024	Automatic Spo, Core 108-7A	1/31/2024	\$	6,950.00	2/12/2024	182466
Vehicle Maintenance	Pacifico Marple Ford	1/25/2024	TCM Program for Trans 108-7A	1/31/2024	\$	184.99	2/12/2024	182466
Vehicle Maintenance	Pacifico Marple Ford	1/25/2024	RETURN - Core	1/31/2024	\$	(1,250.00)	2/12/2024	182466
Total 01412510702:						8,377.89		
1413150002								
Life Insurance	North American Benefits Company	1/22/2024	Group Term Life Insurance	1/31/2024	\$	79.80	1/30/2024	182320
Total 01413150002:					\$	79.80		
1413150502								
Health Benefits	DelCo Public Schools Healthcare Trst	1/2/2024	Health Benefits	1/31/2024	\$	8,118.79	1/16/2024	182272
Total 01413150502:					\$	8,118.79		
1413151002								
Rx/Dental/Vision/LTD	Express Scripts Inc	1/2/2024	Prescription Benefits	1/31/2024	\$	717.54	1/9/2024	422
Rx/Dental/Vision/LTD	Express Scripts Inc	1/12/2024	Prescription Benefits	1/31/2024	\$	71.02	1/12/2024	426
Rx/Dental/Vision/LTD	Express Scripts Inc	1/22/2024	Prescription Benefits	1/31/2024	\$	14.68	1/30/2024	430
Rx/Dental/Vision/LTD	Express Scripts Inc	1/2/2024	Prescription Benefits	1/31/2024	\$	717.54	1/9/2024	7092
Rx/Dental/Vision/LTD	Express Scripts Inc	1/2/2024	Prescription Benefits	1/31/2024	\$	(717.54)	1/9/2024	7092
Rx/Dental/Vision/LTD	North American Benefits Company	1/22/2024	Long Term Civilian Disability Insurance	2/29/2024	\$	188.34	2/6/2024	182337
Total 01413151002:					\$	991.58		
1413152002								
Workers Compensation	Arthur J Gallagher Risk Mgmt Serv Inc	1/8/2024	2022 WC Audit	1/31/2024	\$	315.09	1/16/2024	182263
Total 01413152002:					\$	315.09		
1413200002								
Miscellaneous Expense	J & J Landscaping Management, LLC	8/7/2023	Prop Main't - 217 E Marthart	1/31/2024	\$	295.00	1/9/2024	182251
Miscellaneous Expense	J & J Landscaping Management, LLC	9/6/2023	Prop Main't - 705 Haverford	1/31/2024	\$	865.00	1/9/2024	182251
Miscellaneous Expense	J & J Landscaping Management, LLC	9/6/2023	Prop Main't - 701 Haverford	1/31/2024	\$	485.00	1/9/2024	182251
Miscellaneous Expense	J & J Landscaping Management, LLC	10/23/2023	Prop Main't - 217 E Marthart	1/31/2024	\$	285.00	1/9/2024	182251
Total 01413200002:					\$	1,930.00		
1413200202								
Office Supplies	Hockeytown 19083 LLC	1/18/2024	(6) Shirts - Haverford Twp Codes	1/31/2024	\$	188.00	2/12/2024	182423
Office Supplies	Nuss Printing Inc	1/17/2024	(2000) Construction Inspection Forms	1/31/2024	\$	277.00	2/12/2024	182461
Office Supplies	Office Basics, Inc	1/24/2024	Office Supplies	1/31/2024	\$	17.16	2/12/2024	182462

Office Supplies	Office Basics, Inc	1/27/2024	Office Supplies	1/31/2024	\$	57.06	2/12/2024	182462
Total 01413200202:					\$	539.22		
1413210102								
Postage Expense	FP Finance Program	12/27/2023	Postage Meter Lease	1/31/2024	\$	31.25	1/9/2024	182250
Postage Expense	FP Finance Program	1/29/2024	Postage Meter Lease	2/29/2024	\$	31.25	2/6/2024	182335
Total 01413210102:					\$	62.50		
1413290202								
Legal Expenses	Kilkenny Law, LLC	1/2/2024	Legal Services - General	1/31/2024	\$	87.50	2/12/2024	182437
Total 01413290202:					\$	87.50		
1413290302								
Prof Services - Special	Keystone Municipal Services, Inc	12/30/2023	Building Inspection Services	1/31/2024	\$	5,400.00	2/12/2024	182435
Prof Services - Special	Keystone Municipal Services, Inc	1/24/2024	Building Inspection Services	1/31/2024	\$	5,925.00	2/12/2024	182435
Total 01413290302:					\$	11,325.00		
1413300002								
Communications	Comcast Business	1/1/2024	Cable Service	1/31/2024	\$	113.96	1/16/2024	182268
Communications	Xtel Communications, Inc	1/1/2024	Phone Expense	1/31/2024	\$	51.83	1/16/2024	182293
Communications	AT & T Mobility	1/16/2024	Cellular Service	2/29/2024	\$	357.83	2/6/2024	182331
Total 01413300002:					\$	523.62		
1413400002								
Copier Lease/Maintenance	Toshiba America Business Solutions	12/25/2023	Copier Maintenance	1/31/2024	\$	18.31	1/9/2024	182258
Copier Lease/Maintenance	Toshiba Financial Service	12/28/2023	Copier Lease	1/31/2024	\$	62.72	1/9/2024	182259
Copier Lease/Maintenance	Toshiba Financial Service	1/23/2024	Copier Lease	1/31/2024	\$	62.72	1/30/2024	182326
Copier Lease/Maintenance	Toshiba America Business Solutions	1/22/2024	Copier Maintenance	2/29/2024	\$	10.81	2/6/2024	182344
Total 01413400002:					\$	154.56		
1413411702								
Vehicle Insurance	Arthur J Gallagher Risk Mgmt Serv Inc	12/18/2023	P & C Insurance Premium "3rd Installment	1/31/2024	\$	1,714.43	1/30/2024	182312
Total 01413411702:					\$	1,714.43		
1413510002								
Vehicle Fuel	Petroleum Traders Corp	12/27/2023	Unleaded	1/31/2024	\$	123.72	2/12/2024	182473
Vehicle Fuel	Petroleum Traders Corp	1/19/2024	Unleaded	1/31/2024	\$	107.45	2/12/2024	182473
Total 01413510002:					\$	231.17		
1416150002								
Life Insurance	North American Benefits Company	1/22/2024	Group Term Life Insurance	1/31/2024	\$	16.80	1/30/2024	182320
Total 01416150002:					\$	16.80		
1416150502								
Health Benefits	DelCo Public Schools Healthcare Trst	1/2/2024	Health Benefits	1/31/2024	\$	2,352.89	1/16/2024	182272
Total 01416150502:					\$	2,352.89		
1416151002								
Rx/Dental/Vision/LTD	Express Scripts Inc	1/2/2024	Prescription Benefits	1/31/2024	\$	43.35	1/9/2024	422
Rx/Dental/Vision/LTD	Express Scripts Inc	1/12/2024	Prescription Benefits	1/31/2024	\$	125.21	1/12/2024	426
Rx/Dental/Vision/LTD	Express Scripts Inc	1/2/2024	Prescription Benefits	1/31/2024	\$	43.35	1/9/2024	7092
Rx/Dental/Vision/LTD	Express Scripts Inc	1/2/2024	Prescription Benefits	1/31/2024	\$	(43.35)	1/9/2024	7092
Rx/Dental/Vision/LTD	North American Benefits Company	1/22/2024	Long Term Civilian Disability Insurance	2/29/2024	\$	48.09	2/6/2024	182337
Total 01416151002:					\$	216.65		
1416152002								
Workers Compensation	Arthur J Gallagher Risk Mgmt Serv Inc	1/8/2024	2022 WC Audit	1/31/2024	\$	93.36	1/16/2024	182263
Total 01416152002:					\$	93.36		
1416200002								
Miscellaneous Expense	Sir Speedy Printing Center #7099	1/5/2024	(6) Booklets - Zoning Chapter	1/31/2024	\$	110.00	2/12/2024	182492
Total 01416200002:					\$	110.00		
1416200202								
Office Supplies	Office Basics, Inc	1/2/2024	Office Supplies	1/31/2024	\$	9.40	2/12/2024	182462
Office Supplies	Office Basics, Inc	1/24/2024	Office Supplies	1/31/2024	\$	20.32	2/12/2024	182462
Office Supplies	Office Basics, Inc	1/26/2024	Office Supplies	1/31/2024	\$	9.40	2/12/2024	182462
Total 01416200202:					\$	39.12		
1416210102								
Postage Expense	FP Finance Program	12/27/2023	Postage Meter Lease	1/31/2024	\$	31.25	1/9/2024	182250
Postage Expense	FP Finance Program	1/29/2024	Postage Meter Lease	2/29/2024	\$	31.25	2/6/2024	182335
Total 01416210102:					\$	62.50		

1416210602								
Advertising	21st Century Media-Philly Cluster	12/27/2023	Advertising	1/31/2024	\$ 413.88	2/12/2024	182346	
Total 01416210602:					\$ 413.88			
1416290202								
Legal Expenses	Kilkenny Law, LLC	1/2/2024	Legal Services - General	1/31/2024	\$ 3,255.00	2/12/2024	182437	
Legal Expenses	Kilkenny Law, LLC	1/2/2024	Legal Services - General Litigation	1/31/2024	\$ 245.00	2/12/2024	182437	
Legal Expenses	Kilkenny Law, LLC	1/2/2024	Legal Services - Mandamus Litigation	1/31/2024	\$ 2,342.50	2/12/2024	182437	
Legal Expenses	Raffaele & Puppio, LLP	1/5/2024	ZHB Solicitor - Appeals/Hearings	1/31/2024	\$ 2,951.00	2/12/2024	182482	
Total 01416290202:					\$ 8,793.50			
1416290302								
Prof Svcs - Special Cases	Discover Haverford	2/1/2024	2024 Quarterly Operating Contribution	1/31/2024	\$ 26,908.75	2/12/2024	182394	
Prof Svcs - Special Cases	Keystone Municipal Services, Inc	12/30/2023	Building Inspection Services	1/31/2024	\$ 3,888.75	2/12/2024	182435	
Prof Svcs - Special Cases	Keystone Municipal Services, Inc	1/24/2024	Building Inspection Services	1/31/2024	\$ 3,458.75	2/12/2024	182435	
Prof Svcs - Special Cases	McNichol, Byrne, & Matlawski, PC	1/17/2024	Legal services - Billboards	1/31/2024	\$ 857.50	2/12/2024	182451	
Prof Svcs - Special Cases	McNichol, Byrne, & Matlawski, PC	1/17/2024	Legal services - Starbucks	1/31/2024	\$ 17.50	2/12/2024	182451	
Total 01416290302:					\$ 35,131.25			
1416290402								
Engineering Fees	Pennoni Associates, Inc	2/1/2024	Eagle Rd YMCA - Adt'l Easements	1/31/2024	\$ 930.00	2/12/2024	182469	
Total 01416290402:					\$ 930.00			
1416300002								
Communications	Comcast Business	1/1/2024	Cable Service	1/31/2024	\$ 30.93	1/16/2024	182268	
Communications	Xtel Communications, Inc	1/1/2024	Phone Expense	1/31/2024	\$ 14.07	1/16/2024	182293	
Communications	AT & T Mobility	1/16/2024	Cellular Service	2/29/2024	\$ 44.73	2/6/2024	182331	
Total 01416300002:					\$ 89.73			
1416400002								
Copier Lease/Maintenance	Toshiba America Business Solutions	12/25/2023	Copier Maintenance	1/31/2024	\$ 15.50	1/9/2024	182258	
Copier Lease/Maintenance	Toshiba Financial Service	12/28/2023	Copier Lease	1/31/2024	\$ 51.46	1/9/2024	182259	
Copier Lease/Maintenance	Toshiba Financial Service	1/23/2024	Copier Lease	1/31/2024	\$ 51.46	1/30/2024	182326	
Copier Lease/Maintenance	Toshiba America Business Solutions	1/22/2024	Copier Maintenance	2/29/2024	\$ 9.00	2/6/2024	182344	
Total 01416400002:					\$ 127.42			
1416901002								
Hearing Transcripts	Arlene M. LaRosa, RPR	1/10/2024	Court reporting	1/31/2024	\$ 397.00	2/12/2024	182360	
Total 01416901002:					\$ 397.00			
1427150002								
Life Insurance	North American Benefits Company	1/22/2024	Group Term Life Insurance	1/31/2024	\$ 278.40	1/30/2024	182320	
Total 01427150002:					\$ 278.40			
1427150502								
Health Benefits	DelCo Public Schools Healthcare Trst	1/2/2024	Health Benefits	1/31/2024	\$ 33,210.59	1/16/2024	182272	
Total 01427150502:					\$ 33,210.59			
1427151002								
Rx/Dental/Vision/LTD	Express Scripts Inc	1/2/2024	Prescription Benefits	1/31/2024	\$ 1,427.67	1/9/2024	422	
Rx/Dental/Vision/LTD	Express Scripts Inc	1/12/2024	Prescription Benefits	1/31/2024	\$ 1,746.67	1/12/2024	426	
Rx/Dental/Vision/LTD	Express Scripts Inc	1/22/2024	Prescription Benefits	1/31/2024	\$ 302.89	1/30/2024	430	
Rx/Dental/Vision/LTD	Express Scripts Inc	1/2/2024	Prescription Benefits	1/31/2024	\$ 1,427.67	1/9/2024	7092	
Rx/Dental/Vision/LTD	Express Scripts Inc	1/2/2024	Prescription Benefits	1/31/2024	\$ (1,427.67)	1/9/2024	7092	
Rx/Dental/Vision/LTD	North American Benefits Company	1/22/2024	Long Term Civilian Disability Insurance	2/29/2024	\$ 557.63	2/6/2024	182337	
Total 01427151002:					\$ 4,034.86			
1427152002								
Workers Compensation	Arthur J Gallagher Risk Mgmt Serv Inc	1/8/2024	2022 WC Audit	1/31/2024	\$ 1,143.66	1/16/2024	182263	
Total 01427152002:					\$ 1,143.66			
1427200002								
Miscellaneous Expense	Patrick McNelis	1/30/2024	Reimb - CDL	2/29/2024	\$ 78.00	2/6/2024	182338	
Miscellaneous Expense	Sir Speedy Printing Center #7099	11/10/2023	(2500) Door Hangers	1/31/2024	\$ 2,070.00	2/12/2024	182492	
Total 01427200002:					\$ 2,148.00			
1427272202								
Trash Billing	Postmaster	1/26/2024	2024 Tax Bill Postage	1/31/2024	\$ 3,531.94	1/26/2024	182310	
Total 01427272202:					\$ 3,531.94			
1427277002								
Bulk Pick Up Expense	JPS Equipment Co., Inc	1/31/2024	Bulk Trash Collection	1/31/2024	\$ 5,459.00	2/12/2024	182432	

Total 01427277002:					\$	5,459.00		
1427277102								
Recycling	BFI-King Of Prussia Recyclery	12/31/2023	Single Stream Recycling	1/31/2024	\$	36,005.27	2/12/2024	182366
Recycling	Spectrum Letterbox	1/2/2024	2024 Recycling Calendar Envelopes	1/31/2024	\$	1,325.00	2/12/2024	182493
Recycling	Spectrum Letterbox	1/2/2024	2024 Recycling Calenders Mailing	1/31/2024	\$	1,495.00	2/12/2024	182493
Recycling	Spectrum Letterbox	1/2/2024	2024 Recycling Calendar Mailing Printing	1/31/2024	\$	3,175.00	2/12/2024	182493
Total 01427277102:					\$	42,000.27		
1427277202								
Landfill/Disposal Cost	Delaware County Solid Waste Authority	1/3/2024	Municipal Waste	1/31/2024	\$	111,649.11	2/12/2024	182390
Landfill/Disposal Cost	Delaware County Solid Waste Authority	1/3/2024	Municipal Waste	1/31/2024	\$	(3,777.10)	2/12/2024	182390
Landfill/Disposal Cost	Victory Gardens Inc	12/20/2023	Brush Removal	1/31/2024	\$	200.00	2/12/2024	182514
Landfill/Disposal Cost	Victory Gardens Inc	12/13/2023	Brush Removal	1/31/2024	\$	600.00	2/12/2024	182514
Total 01427277202:					\$	108,672.01		
1427280302								
Uniform Regular	James McCans	12/28/2023	Reimb. - Uniforms (Sharp Box)	1/31/2024	\$	74.22	1/9/2024	182252
Uniform Regular	James McCans	12/28/2023	Reimb. - Uniforms	1/31/2024	\$	123.96	1/9/2024	182252
Uniform Regular	Flocco Inc	8/30/2023	Work Boots	1/31/2024	\$	3,875.00	1/16/2024	182275
Total 01427280302:					\$	4,073.18		
1427300002								
Communications	Comcast	1/17/2024	Cable Service - 1 Hilltop Rd	1/31/2024	\$	78.42	1/23/2024	182300
Communications	AT & T Mobility	1/16/2024	Cellular Service	2/29/2024	\$	89.46	2/6/2024	182331
Total 01427300002:					\$	167.88		
1427300102								
Radio Rent/Maintenance	Eagle Wireless Communications LLC	1/15/2024	Geotab Monthly Service - Public Works	1/31/2024	\$	288.77	2/12/2024	182397
Total 01427300102:					\$	288.77		
1427411702								
Vehicle Insurance	Arthur J Gallagher Risk Mgmt Serv Inc	12/18/2023	P & C Insurance Premium - 3rd Installment	1/31/2024	\$	6,057.64	1/30/2024	182312
Total 01427411702:					\$	6,057.64		
1427510002								
Vehicle Fuel	Petroleum Traders Corp	12/27/2023	Unleaded	1/31/2024	\$	241.82	2/12/2024	182473
Vehicle Fuel	Petroleum Traders Corp	1/19/2024	Unleaded	1/31/2024	\$	209.98	2/12/2024	182473
Vehicle Fuel	School District of Haverford Township	1/29/2024	Diesel Fuel	1/31/2024	\$	15,170.09	2/12/2024	182488
Vehicle Fuel	School District of Haverford Township	1/29/2024	Diesel Fuel	1/31/2024	\$	84.37	2/12/2024	182488
Vehicle Fuel	School District of Haverford Township	1/29/2024	Diesel Fuel	1/31/2024	\$	16.03	2/12/2024	182488
Total 01427510002:					\$	15,722.29		
1427510702								
Vehicle Maintenance	95 Signs Inc	1/10/2024	Outfit S-18	1/31/2024	\$	850.00	2/12/2024	182348
Vehicle Maintenance	Ardmore Tire Inc	12/20/2023	(3) Tires S-22, 23	1/31/2024	\$	760.00	2/12/2024	182359
Vehicle Maintenance	Ardmore Tire Inc	1/3/2024	(4) Tires S-16, 17	1/31/2024	\$	785.00	2/12/2024	182359
Vehicle Maintenance	Ardmore Tire Inc	1/6/2024	Tires S-25	1/31/2024	\$	350.00	2/12/2024	182359
Vehicle Maintenance	Ardmore Tire Inc	1/12/2024	(5) Tires S-25, 26, 30	1/31/2024	\$	1,025.00	2/12/2024	182359
Vehicle Maintenance	Berrodin Parts Warehouse	12/21/2023	RETURN - Reman Altern, (2) Cores	1/31/2024	\$	(399.03)	2/12/2024	182364
Vehicle Maintenance	Del-Val International Trucks, Inc	12/18/2023	Core S-30	1/31/2024	\$	1,427.41	2/12/2024	182392
Vehicle Maintenance	Del-Val International Trucks, Inc	12/20/2023	REFUND - Core	1/31/2024	\$	(450.00)	2/12/2024	182392
Vehicle Maintenance	Del-Val International Trucks, Inc	12/21/2023	Sensor, Core S-24	1/31/2024	\$	846.26	2/12/2024	182392
Vehicle Maintenance	Del-Val International Trucks, Inc	12/21/2023	Nitrogen Sensor, Core S-24	1/31/2024	\$	827.73	2/12/2024	182392
Vehicle Maintenance	Del-Val International Trucks, Inc	12/22/2023	Turbocharge S-19	1/31/2024	\$	1,800.98	2/12/2024	182392
Vehicle Maintenance	Del-Val International Trucks, Inc	12/22/2023	Dual Filter S-20	1/31/2024	\$	109.77	2/12/2024	182392
Vehicle Maintenance	Del-Val International Trucks, Inc	12/22/2023	Filter, Belt, S-15, 17, 22, 24, 29, 30	1/31/2024	\$	480.65	2/12/2024	182392
Vehicle Maintenance	Del-Val International Trucks, Inc	12/26/2023	Air pipe, S-19	1/31/2024	\$	271.56	2/12/2024	182392
Vehicle Maintenance	Del-Val International Trucks, Inc	1/4/2024	Sendure Hose, Radiator Outlet S-27	1/31/2024	\$	187.46	2/12/2024	182392
Vehicle Maintenance	Del-Val International Trucks, Inc	1/3/2024	Blower Motor, Resistor Linear S-16	1/31/2024	\$	431.45	2/12/2024	182392
Vehicle Maintenance	Del-Val International Trucks, Inc	1/4/2024	Seal Kit, Sensor Assembly S-21	1/31/2024	\$	487.70	2/12/2024	182392
Vehicle Maintenance	Del-Val International Trucks, Inc	1/8/2024	(3) Press Fuel Kits S-21	1/31/2024	\$	273.27	2/12/2024	182392
Vehicle Maintenance	Del-Val International Trucks, Inc	1/16/2024	(2) Hoses S-27	1/31/2024	\$	194.16	2/12/2024	182392
Vehicle Maintenance	Del-Val International Trucks, Inc	1/11/2024	Hose Coolant, Tank Surge S-21	1/31/2024	\$	591.25	2/12/2024	182392
Vehicle Maintenance	Del-Val International Trucks, Inc	1/12/2024	Transmission, Core S-20	1/31/2024	\$	8,947.89	2/12/2024	182392
Vehicle Maintenance	GranTurk Equipment Company Inc	12/20/2023	Return Pipe S-27	1/31/2024	\$	254.70	2/12/2024	182414
Vehicle Maintenance	GranTurk Equipment Company Inc	1/9/2024	Hyc0 M-PTO S-26	1/31/2024	\$	3,903.75	2/12/2024	182414

Vehicle Maintenance	GranTurk Equipment Company Inc	1/15/2024	(4) New Style Solenoid S-23, 27	1/31/2024	\$ 1,641.10	2/12/2024	182414
Vehicle Maintenance	K & S Towing & Recovery Inc	12/27/2023	Towing S-22	1/31/2024	\$ 678.00	2/12/2024	182433
Vehicle Maintenance	Pacifico Marple Ford	1/12/2024	Fuel Filter S-100	1/31/2024	\$ 185.00	2/12/2024	182466
Vehicle Maintenance	Pacifico Marple Ford	1/12/2024	(2) Element Filters S-100	1/31/2024	\$ 178.90	2/12/2024	182466
Vehicle Maintenance	Penn Power Group	12/27/2023	Gasket, S-20	1/31/2024	\$ 251.10	2/12/2024	182468
Vehicle Maintenance	Penn Power Group	12/29/2023	Solenoid Assy, Harness Assy S-20	1/31/2024	\$ 380.07	2/12/2024	182468
Vehicle Maintenance	Triple R Truck Parts	1/19/2024	(8) Fender Guides, (3) Long Strokes	1/31/2024	\$ 862.33	2/12/2024	182504
Vehicle Maintenance	TruckPro LLC Corp	12/20/2023	(10) Blade, (6) Batteries, S-21, 67, 17	1/31/2024	\$ 960.54	2/12/2024	182507
Vehicle Maintenance	TruckPro LLC Corp	12/22/2023	(6) Lube Filters S-24, 26, 27	1/31/2024	\$ 165.94	2/12/2024	182507
Vehicle Maintenance	TruckPro LLC Corp	1/3/2024	(2) Brk Kits,(2) Batteries S-30, 67	1/31/2024	\$ 562.37	2/12/2024	182507
Vehicle Maintenance	TruckPro LLC Corp	1/10/2024	(2) Brk Kits, (24) Brk Clnrs, (3) Lube Fltr S-27, 28	1/31/2024	\$ 552.33	2/12/2024	182507
Total 01427510702:					\$ 30,374.64		
1427605002							
Major Equipment	Ascendance Truck LLC	1/5/2024	2024 Cab and Chassis S-18	1/31/2024	\$ 107,983.00	1/23/2024	182295
Major Equipment	GranTurk Equipment Company Inc	12/15/2023	Trash & Recycling Body S-18	1/31/2024	\$ 93,664.50	1/23/2024	182303
Total 01427605002:					\$ 201,647.50		
1430150002							
Life Insurance	North American Benefits Company	1/22/2024	Group Term Life Insurance	1/31/2024	\$ 354.90	1/30/2024	182320
Total 01430150002:					\$ 354.90		
1430150502							
Health Benefits	DelCo Public Schools Healthcare Trst	1/2/2024	Health Benefits	1/31/2024	\$ 34,485.07	1/16/2024	182272
Total 01430150502:					\$ 34,485.07		
1430151002							
Rx/Dental/Vision/LTD	Express Scripts Inc	1/2/2024	Prescription Benefits	1/31/2024	\$ 7,135.17	1/9/2024	422
Rx/Dental/Vision/LTD	Express Scripts Inc	1/12/2024	Prescription Benefits	1/31/2024	\$ 6,044.10	1/12/2024	426
Rx/Dental/Vision/LTD	Express Scripts Inc	1/22/2024	Prescription Benefits	1/31/2024	\$ 4,082.58	1/30/2024	430
Rx/Dental/Vision/LTD	Express Scripts Inc	1/2/2024	Prescription Benefits	1/31/2024	\$ 7,135.17	1/9/2024	7092
Rx/Dental/Vision/LTD	Express Scripts Inc	1/2/2024	Prescription Benefits	1/31/2024	\$ (7,135.17)	1/9/2024	7092
Rx/Dental/Vision/LTD	Vision Benefits of America	1/5/2024	Vision Benefits	1/31/2024	\$ 152.00	1/23/2024	182309
Rx/Dental/Vision/LTD	North American Benefits Company	1/22/2024	Long Term Civilian Disability Insurance	2/29/2024	\$ 803.89	2/6/2024	182337
Total 01430151002:					\$ 18,217.74		
1430152002							
Workers Compensation	Arthur J Gallagher Risk Mgmt Serv Inc	1/8/2024	2022 WC Audit	1/31/2024	\$ 1,435.41	1/16/2024	182263
Total 01430152002:					\$ 1,435.41		
1430200002							
Miscellaneous Expense	ReadyRefresh by Nestle Inc	1/6/2024	Water Service	1/31/2024	\$ 155.28	1/16/2024	182289
Miscellaneous Expense	A-Jon Construction Inc	12/13/2023	Dump	1/31/2024	\$ 234.00	2/12/2024	182352
Miscellaneous Expense	Bound Tree Medical LLC	1/25/2024	SafeGrip Gloves	1/31/2024	\$ 315.80	2/12/2024	182368
Miscellaneous Expense	Cardone-Nuss Printing	12/18/2023	(6) Military Banners	1/31/2024	\$ 628.50	2/12/2024	182373
Miscellaneous Expense	T. Frank McCall's, Inc	1/11/2024	Maintenance Items	1/31/2024	\$ 1,044.90	2/12/2024	182499
Miscellaneous Expense	T. Frank McCall's, Inc	1/25/2024	Maintenance Items	1/31/2024	\$ 598.10	2/12/2024	182499
Miscellaneous Expense	T. Frank McCall's, Inc	1/29/2024	Maintenance Items	1/31/2024	\$ 157.86	2/12/2024	182499
Miscellaneous Expense	Yearsley's Service, Ltd	1/3/2024	(2) Keys	1/31/2024	\$ 14.00	2/12/2024	182519
Total 01430200002:					\$ 3,148.44		
1430200202							
Office Supplies	Office Basics, Inc	1/2/2024	Office Supplies	1/31/2024	\$ 9.40	2/12/2024	182462
Office Supplies	Office Basics, Inc	1/3/2024	Office Supplies	1/31/2024	\$ 191.50	2/12/2024	182462
Office Supplies	Office Basics, Inc	1/10/2024	Office Supplies	1/31/2024	\$ 39.70	2/12/2024	182462
Office Supplies	Office Basics, Inc	1/10/2024	Office Supplies	1/31/2024	\$ 94.00	2/12/2024	182462
Office Supplies	Office Basics, Inc	1/24/2024	Office Supplies	1/31/2024	\$ 14.26	2/12/2024	182462
Office Supplies	Office Basics, Inc	1/26/2024	Office Supplies	1/31/2024	\$ 9.40	2/12/2024	182462
Office Supplies	Office Basics, Inc	1/31/2024	Office Supplies	1/31/2024	\$ 291.69	2/12/2024	182462
Total 01430200202:					\$ 649.95		
1430210102							
Postage Expense	FP Finance Program	12/27/2023	Postage Meter Lease	1/31/2024	\$ 6.25	1/9/2024	182250
Postage Expense	FP Finance Program	1/29/2024	Postage Meter Lease	2/29/2024	\$ 6.25	2/6/2024	182335
Total 01430210102:					\$ 12.50		
1430230802							
Leaf Disposal	Foley Inc	12/5/2023	RETURN - Equipment Protection Plan	1/31/2024	\$ (2,631.12)	1/23/2024	182302

Leaf Disposal	Foley Inc	1/16/2024	RETURN - Equipment Protection Plan	1/31/2024	\$	(492.24)	1/23/2024	182302
Leaf Disposal	Foley Inc	1/16/2024	RETURN - Equipment Protection Plan	1/31/2024	\$	(815.36)	1/23/2024	182302
Leaf Disposal	Foley Inc	11/29/2023	Rental - Wheel Loader	1/31/2024	\$	7,135.36	1/23/2024	182302
Leaf Disposal	Foley Inc	12/18/2023	Rental - Wheel Loader	1/31/2024	\$	6,650.36	1/23/2024	182302
Leaf Disposal	American Bio soils & Compost LLC	12/20/2023	Inbound Leaves	1/31/2024	\$	12,298.41	2/12/2024	182355
Leaf Disposal	American Bio soils & Compost LLC	12/25/2023	Inbound Leaves	1/31/2024	\$	1,714.56	2/12/2024	182355
Leaf Disposal	American Bio soils & Compost LLC	1/6/2024	Inbound Leaves	1/31/2024	\$	3,321.79	2/12/2024	182355
Total 01430230802:					\$	27,181.76		
1430273002								
Storm Sewers	Eagle Contracting & Landscaping, Inc	12/22/2023	Emergency Repairs - Eagle & Hollis	1/31/2024	\$	9,240.00	2/12/2024	182396
Storm Sewers	Pennoni Associates, Inc	2/1/2024	Townshipwide Drainage Concerns	1/31/2024	\$	1,060.50	2/12/2024	182469
Storm Sewers	Pennoni Associates, Inc	2/1/2024	Npdes App for Storm Sewers (ms4)	1/31/2024	\$	349.00	2/12/2024	182469
Total 01430273002:					\$	10,649.50		
1430280302								
Uniform Regular	Flocco Inc	8/30/2023	Work Boots	1/31/2024	\$	3,571.00	1/16/2024	182275
Total 01430280302:					\$	3,571.00		
1430290402								
Engineering Fees	Pennoni Associates, Inc	2/1/2024	General Traffic Issues	1/31/2024	\$	1,137.75	2/12/2024	182469
Total 01430290402:					\$	1,137.75		
1430300002								
Communications	Comcast Business	1/1/2024	Cable Service	1/31/2024	\$	45.58	1/16/2024	182268
Communications	Xtel Communications, Inc	1/1/2024	Phone Expense	1/31/2024	\$	20.73	1/16/2024	182293
Communications	Comcast	1/17/2024	Cable Service - 1 Hilltop Rd	1/31/2024	\$	78.43	1/23/2024	182300
Communications	AT & T Mobility	1/16/2024	Cellular Service	2/29/2024	\$	313.10	2/6/2024	182331
Total 01430300002:					\$	457.84		
1430300102								
Radio Rent/Maintenance	Eagle Wireless Communications LLC	1/15/2024	Geotab Monthly Service - Public Works	1/31/2024	\$	288.78	2/12/2024	182397
Total 01430300102:					\$	288.78		
1430344202								
Contracted Services	Guidemark Inc	1/15/2024	Line Striping Parkview Drive	1/31/2024	\$	2,800.00	2/12/2024	182415
Total 01430344202:					\$	2,800.00		
1430400002								
Copier Lease/Maintenance	Toshiba America Business Solutions	12/25/2023	Copier Maintenance	1/31/2024	\$	15.50	1/9/2024	182258
Copier Lease/Maintenance	Toshiba Financial Service	12/28/2023	Copier Lease	1/31/2024	\$	51.46	1/9/2024	182259
Copier Lease/Maintenance	Toshiba Financial Service	1/23/2024	Copier Lease	1/31/2024	\$	51.46	1/30/2024	182326
Copier Lease/Maintenance	Toshiba America Business Solutions	1/22/2024	Copier Maintenance	2/29/2024	\$	9.00	2/6/2024	182344
Total 01430400002:					\$	127.42		
1430411702								
Vehicle Insurance	Arthur J Gallagher Risk Mgmt Serv Inc	12/18/2023	P & C Insurance Premium - 3rd Installment	1/31/2024	\$	13,886.86	1/30/2024	182312
Total 01430411702:					\$	13,886.86		
1430430002								
Maint & Repair Equipment	Main Line Mower-Tree Care Supplies	1/9/2024	Service - Repair Muffler Threads	1/31/2024	\$	324.34	2/12/2024	182444
Total 01430430002:					\$	324.34		
1430430102								
Maint & Repair Facilities	Bird Control Services Inc	1/3/2024	Bird Control Services	1/31/2024	\$	102.00	2/12/2024	182367
Maint & Repair Facilities	Grainger	12/21/2023	Thermostat	1/31/2024	\$	53.93	2/12/2024	182413
Total 01430430102:					\$	155.93		
1430510002								
Vehicle Fuel	PA DEP	12/5/2023	Storage Tank Permit - 1 Hilltop Road	1/31/2024	\$	50.00	1/30/2024	182321
Vehicle Fuel	Petroleum Traders Corp	12/27/2023	Unleaded	1/31/2024	\$	1,827.73	2/12/2024	182473
Vehicle Fuel	Petroleum Traders Corp	12/27/2023	Unleaded	1/31/2024	\$	224.95	2/12/2024	182473
Vehicle Fuel	Petroleum Traders Corp	1/19/2024	Unleaded	1/31/2024	\$	1,587.10	2/12/2024	182473
Vehicle Fuel	Petroleum Traders Corp	1/19/2024	Unleaded	1/31/2024	\$	195.33	2/12/2024	182473
Vehicle Fuel	School District of Haverford Township	1/29/2024	Diesel Fuel	1/31/2024	\$	8,075.65	2/12/2024	182488
Total 01430510002:					\$	11,960.76		
1430510702								
Vehicle Maintenance	Foley Inc	12/13/2023	RETURN - Alternator	1/31/2024	\$	(605.22)	1/23/2024	182302
Vehicle Maintenance	Foley Inc	12/15/2023	RETURN - Reporting Subscription	1/31/2024	\$	(10.00)	1/23/2024	182302
Vehicle Maintenance	Foley Inc	12/15/2023	RETURN - Reporting Subscription	1/31/2024	\$	(10.00)	1/23/2024	182302

Vehicle Maintenance	Foley Inc	12/15/2023	RETURN - Reporting Subscription	1/31/2024	\$	(10.00)	1/23/2024	182302
Vehicle Maintenance	Foley Inc	12/15/2023	RETURN - Reporting Subscription	1/31/2024	\$	(10.00)	1/23/2024	182302
Vehicle Maintenance	Foley Inc	12/15/2023	RETURN - Reporting Subscription	1/31/2024	\$	(10.00)	1/23/2024	182302
Vehicle Maintenance	Foley Inc	12/15/2023	RETURN - Reporting Subscription	1/31/2024	\$	(10.00)	1/23/2024	182302
Vehicle Maintenance	Foley Inc	12/15/2023	RETURN - Reporting Subscription	1/31/2024	\$	(10.00)	1/23/2024	182302
Vehicle Maintenance	Foley Inc	12/14/2023	Monthly Reporting Subscription	1/31/2024	\$	10.00	1/23/2024	182302
Vehicle Maintenance	Foley Inc	12/14/2023	Monthly Reporting Subscription	1/31/2024	\$	10.00	1/23/2024	182302
Vehicle Maintenance	Foley Inc	12/14/2023	Monthly Reporting Subscription	1/31/2024	\$	10.00	1/23/2024	182302
Vehicle Maintenance	Foley Inc	12/14/2023	Monthly Reporting Subscription	1/31/2024	\$	10.00	1/23/2024	182302
Vehicle Maintenance	Foley Inc	12/14/2023	Monthly Reporting Subscription	1/31/2024	\$	10.00	1/23/2024	182302
Vehicle Maintenance	Foley Inc	12/14/2023	Monthly Reporting Subscription	1/31/2024	\$	10.00	1/23/2024	182302
Vehicle Maintenance	Foley Inc	12/14/2023	Monthly Reporting Subscription	1/31/2024	\$	10.00	1/23/2024	182302
Vehicle Maintenance	Foley Inc	12/19/2023	Air Filter H-239 Skid	1/31/2024	\$	60.22	1/23/2024	182302
Vehicle Maintenance	Berrodin Parts Warehouse	1/9/2024	Blower Motor, Resistor H-30	1/31/2024	\$	164.31	2/12/2024	182364
Vehicle Maintenance	Berrodin Parts Warehouse	1/17/2024	Reman Starter, Core H-51	1/31/2024	\$	122.42	2/12/2024	182364
Vehicle Maintenance	Berrodin Parts Warehouse	1/18/2024	Caliper, Core, Brake Hose B-3	1/31/2024	\$	185.05	2/12/2024	182364
Vehicle Maintenance	Berrodin Parts Warehouse	1/19/2024	(10) Exact Fit H-32, 36, 49, 73	1/31/2024	\$	62.60	2/12/2024	182364
Vehicle Maintenance	Berrodin Parts Warehouse	1/19/2024	(10) Exact Fit H-35, 70, 73	1/31/2024	\$	62.60	2/12/2024	182364
Vehicle Maintenance	Del-Val International Trucks, Inc	12/29/2023	Throttle inlet, Throttle inlet Core H-34	1/31/2024	\$	593.68	2/12/2024	182392
Vehicle Maintenance	Del-Val International Trucks, Inc	1/5/2024	Pan Assy, Pan Oil, Gasket Oil Suction H-37	1/31/2024	\$	1,213.00	2/12/2024	182392
Vehicle Maintenance	Imperial Supplies LLC	1/3/2024	Draw Bar H-60	1/31/2024	\$	112.23	2/12/2024	182426
Vehicle Maintenance	Kelly Industrial Supply	1/19/2024	(50) Hydraulic Hoses, (6) Steel Couplers H-32, 36, 49	1/31/2024	\$	846.98	2/12/2024	182434
Vehicle Maintenance	Kelly Industrial Supply	1/19/2024	(78) Hose Ends, (14) Swivel Crimps H-34, 39, 70, 73	1/31/2024	\$	964.70	2/12/2024	182434
Vehicle Maintenance	Kelly Industrial Supply	1/24/2024	(6) Steel Parts H-34, 39	1/31/2024	\$	134.59	2/12/2024	182434
Vehicle Maintenance	Linde Gas & Equipment Inc	12/22/2023	Cylinder Rental	1/31/2024	\$	214.07	2/12/2024	182439
Vehicle Maintenance	McLenaghan Wholesale Tires Inc	1/26/2024	(2) Tires H-78	1/31/2024	\$	322.00	2/12/2024	182450
Vehicle Maintenance	Pacifico Marple Ford	1/4/2024	Fob Battery M-1	1/31/2024	\$	9.74	2/12/2024	182466
Vehicle Maintenance	Park's Best Car Wash Inc	1/2/2024	Car Washes	1/31/2024	\$	45.00	2/12/2024	182467
Vehicle Maintenance	PetroChoice	12/18/2023	Yard Oil	1/31/2024	\$	978.49	2/12/2024	182472
Vehicle Maintenance	PetroChoice	12/19/2023	Yard Oil	1/31/2024	\$	2,996.40	2/12/2024	182472
Vehicle Maintenance	PetroChoice	1/19/2024	Yard Oil	1/31/2024	\$	5,316.63	2/12/2024	182472
Vehicle Maintenance	Triple R Truck Parts	1/18/2024	(4) Cross Chains, (100) Straps H-37, 38, 49	1/31/2024	\$	514.86	2/12/2024	182504
Vehicle Maintenance	Triple R Truck Parts	1/18/2024	(96) Cross Chains H-32, 36, 70	1/31/2024	\$	949.44	2/12/2024	182504
Vehicle Maintenance	TruckPro LLC Corp	1/10/2024	(3) Batteries H-46, 52	1/31/2024	\$	420.18	2/12/2024	182507
Vehicle Maintenance	TruckPro LLC Corp	1/24/2024	(6) Batteries H-66, 70	1/31/2024	\$	936.31	2/12/2024	182507
Total 01430510702:					\$	16,620.28		
1430600002								
Minor Equipment	Fisher's Ace Hardware	1/23/2024	Hose, Q-Connect Yard	1/31/2024	\$	66.98	2/12/2024	182405
Minor Equipment	Galantino Supply Company Inc	1/24/2024	Chop Saw	1/31/2024	\$	1,310.50	2/12/2024	182410
Minor Equipment	Main Line Mower-Tree Care Supplies	1/25/2024	Guide Bar, Saw, Filter Housing	1/31/2024	\$	431.97	2/12/2024	182444
Total 01430600002:					\$	1,809.45		
1430605002								
Major Equipment	Ascendance Truck Pennsylvania LLC	1/24/2024	2024 Cab and Chassis H-73	1/31/2024	\$	89,758.00	2/12/2024	182361
Major Equipment	H A DeHart & Son	1/18/2024	Truck Body H-73	1/31/2024	\$	79,985.00	2/12/2024	182416
Total 01430605002:					\$	169,743.00		
1432200002								
Miscellaneous Expense	Llanerch Diner	1/25/2024	Food - Snow Storm	2/29/2024	\$	251.85	2/6/2024	182336
Total 01432200002:					\$	251.85		
1432900602								
Snow Removal Materials	Aqua Pennsylvania	12/20/2023	1 Hilltop Rd - Brine Machine	1/31/2024	\$	178.84	1/9/2024	182244
Snow Removal Materials	Aqua Pennsylvania	1/22/2024	1 Hilltop Rd - Brine Machine	1/31/2024	\$	169.75	1/30/2024	182311
Snow Removal Materials	A Marinelli & Sons Inc	1/26/2024	(110) Calcium Pellets	1/31/2024	\$	2,634.50	2/12/2024	182349
Snow Removal Materials	Eastern Salt Company Inc	1/28/2024	Rock Salt	1/31/2024	\$	5,119.08	2/12/2024	182399
Total 01432900602:					\$	8,102.17		
1434201402								
Street Lights Electric	Peco Energy	12/28/2023	Grove Rd	1/31/2024	\$	11.02	1/9/2024	182256
Street Lights Electric	Peco Energy	12/28/2023	2325B Darby Rd - Streetlights	1/31/2024	\$	28,617.42	1/9/2024	182256
Street Lights Electric	Peco Energy	1/29/2024	Grove Rd	2/29/2024	\$	11.05	2/6/2024	182339
Street Lights Electric	Peco Energy	1/29/2024	2325B Darby Rd - Streetlights	2/29/2024	\$	28,699.69	2/6/2024	182339

Total 01434201402:					\$	57,339.18	
1434201502							
Traffic Signals Electric	Peco Energy	12/28/2023	2325 Darby Rd -Traffic Signals	1/31/2024	\$	2,312.69	1/9/2024 182256
Traffic Signals Electric	Peco Energy	1/29/2024	2325 Darby Rd -Traffic Signals	2/29/2024	\$	2,314.38	2/6/2024 182339
Total 01434201502:					\$	4,627.07	
1434231202							
Signal/Light Maintenance	Signal Service, Inc	9/27/2023	PA One Mark Out - Haverford Ardmore	1/31/2024	\$	120.00	2/12/2024 182490
Signal/Light Maintenance	Signal Service, Inc	9/27/2023	PA One Mark Out - Darby & College	1/31/2024	\$	120.00	2/12/2024 182490
Signal/Light Maintenance	Signal Service, Inc	9/27/2023	Darby & Benedict	1/31/2024	\$	412.50	2/12/2024 182490
Signal/Light Maintenance	Signal Service, Inc	10/6/2023	Darby & Benedict	1/31/2024	\$	727.50	2/12/2024 182490
Signal/Light Maintenance	Signal Service, Inc	10/6/2023	Coopertown School Lights	1/31/2024	\$	105.00	2/12/2024 182490
Signal/Light Maintenance	Signal Service, Inc	10/9/2023	Darby & Llandillo	1/31/2024	\$	210.00	2/12/2024 182490
Signal/Light Maintenance	Signal Service, Inc	10/9/2023	Darby & Llandillo	1/31/2024	\$	462.00	2/12/2024 182490
Signal/Light Maintenance	Signal Service, Inc	10/9/2023	PA One Mark Out - Landover & Haverford	1/31/2024	\$	120.00	2/12/2024 182490
Signal/Light Maintenance	Signal Service, Inc	10/9/2023	PA One Mark Out - Twp. Line & Warrior	1/31/2024	\$	120.00	2/12/2024 182490
Signal/Light Maintenance	Signal Service, Inc	10/9/2023	Ardmore & Morris	1/31/2024	\$	210.00	2/12/2024 182490
Signal/Light Maintenance	Signal Service, Inc	10/9/2023	PA One Mark Out - Darby & Dartmouth	1/31/2024	\$	120.00	2/12/2024 182490
Signal/Light Maintenance	Signal Service, Inc	10/23/2023	Earlington & Mill	1/31/2024	\$	267.50	2/12/2024 182490
Signal/Light Maintenance	Signal Service, Inc	10/23/2023	Earlington & Mill	1/31/2024	\$	412.50	2/12/2024 182490
Signal/Light Maintenance	Signal Service, Inc	10/23/2023	PA One Mark Out - WCP & Darby	1/31/2024	\$	120.00	2/12/2024 182490
Signal/Light Maintenance	Signal Service, Inc	10/23/2023	WCP & Eagle	1/31/2024	\$	1,050.00	2/12/2024 182490
Signal/Light Maintenance	Signal Service, Inc	10/23/2023	Darby & Mill	1/31/2024	\$	315.00	2/12/2024 182490
Signal/Light Maintenance	Signal Service, Inc	10/30/2023	PA One Mark Out - Darby & College	1/31/2024	\$	120.00	2/12/2024 182490
Signal/Light Maintenance	Signal Service, Inc	10/31/2023	PA One Mark Out - Twp. Line & Warrior	1/31/2024	\$	120.00	2/12/2024 182490
Signal/Light Maintenance	Signal Service, Inc	10/31/2023	PA One Mark Out - Drexel & Twp. Line	1/31/2024	\$	120.00	2/12/2024 182490
Signal/Light Maintenance	Signal Service, Inc	10/31/2023	PA One Mark Out - Burmont & Steel	1/31/2024	\$	120.00	2/12/2024 182490
Signal/Light Maintenance	Signal Service, Inc	1/12/2024	PA One Mark Out - Twp Line & WCP	1/31/2024	\$	120.00	2/12/2024 182490
Signal/Light Maintenance	Signal Service, Inc	1/12/2024	Ellis Rd Flashers	1/31/2024	\$	1,674.00	2/12/2024 182490
Signal/Light Maintenance	Signal Service, Inc	1/12/2024	PA One Mark Out - Darby & Mill	1/31/2024	\$	120.00	2/12/2024 182490
Signal/Light Maintenance	Signal Service, Inc	1/12/2024	PA One Mark Out - Earlington & Brookline	1/31/2024	\$	120.00	2/12/2024 182490
Signal/Light Maintenance	Signal Service, Inc	1/12/2024	PA One Mark Out - Twp Line & WCP	1/31/2024	\$	412.50	2/12/2024 182490
Signal/Light Maintenance	Signal Service, Inc	1/12/2024	West Chester Pk & Eagle	1/31/2024	\$	912.50	2/12/2024 182490
Signal/Light Maintenance	Signal Service, Inc	1/12/2024	West Chester Pk & Eagle	1/31/2024	\$	412.50	2/12/2024 182490
Signal/Light Maintenance	Turtle & Hughes, Inc	1/16/2024	Material for Street Lights - INSURANCE	1/31/2024	\$	1,109.75	2/12/2024 182508
Signal/Light Maintenance	Turtle & Hughes, Inc	1/11/2024	Material for Street Lights	1/31/2024	\$	1,562.50	2/12/2024 182508
Total 01434231202:					\$	11,815.75	
1440223302							
Life Insurance - Civilian Ret	North American Benefits Company	1/22/2024	Group Term Life Insurance	1/31/2024	\$	1,258.25	1/30/2024 182320
Total 01440223302:					\$	1,258.25	
1440223902							
Health Benefits - Civilian Ret	DelCo Public Schools Healthcare Trst	1/2/2024	Health Benefits	1/31/2024	\$	11,732.30	1/16/2024 182272
Total 01440223902:					\$	11,732.30	
1440224602							
Rx/Dental/Vision - Civ Retired	Express Scripts Inc	1/2/2024	Prescription Benefits	1/31/2024	\$	190.40	1/9/2024 422
Rx/Dental/Vision - Civ Retired	Express Scripts Inc	1/12/2024	Prescription Benefits	1/31/2024	\$	1,818.95	1/12/2024 426
Rx/Dental/Vision - Civ Retired	Express Scripts Inc	1/12/2024	Prescription Benefits	1/31/2024	\$	338.56	1/12/2024 426
Rx/Dental/Vision - Civ Retired	Express Scripts Inc	1/22/2024	Prescription Benefits	1/31/2024	\$	720.66	1/30/2024 430
Rx/Dental/Vision - Civ Retired	Express Scripts Inc	1/22/2024	Prescription Benefits	1/31/2024	\$	145.38	1/30/2024 430
Rx/Dental/Vision - Civ Retired	Express Scripts Inc	1/2/2024	Prescription Benefits	1/31/2024	\$	190.40	1/9/2024 7092
Rx/Dental/Vision - Civ Retired	Express Scripts Inc	1/2/2024	Prescription Benefits	1/31/2024	\$	(190.40)	1/9/2024 7092
Total 01440224602:						3,213.95	
1440900702							
Operating Subsidy - Library	Peco Energy	12/28/2023	2325 Darby Rd	1/31/2024	\$	789.75	1/9/2024 182256
Operating Subsidy - Library	Peco Energy	12/28/2023	2325 Darby Rd - Electric Elevator Rm	1/31/2024	\$	80.31	1/9/2024 182256
Operating Subsidy - Library	Peco Energy	1/29/2024	2325 Darby Rd	2/29/2024	\$	1,302.89	2/6/2024 182339
Operating Subsidy - Library	Peco Energy	1/29/2024	2325 Darby Rd - Electric Elevator Rm	2/29/2024	\$	81.55	2/6/2024 182339
Operating Subsidy - Library	Fisher's Ace Hardware	1/9/2024	(2) Carpet Bar	1/31/2024	\$	27.98	2/12/2024 182405
Operating Subsidy - Library	Haverford Township Free Library	2/1/2024	Operating Subsidy/MMO Allocation	1/31/2024	\$	111,692.34	2/12/2024 182417
Operating Subsidy - Library	Jacob Low Hardware	1/9/2023	Door Closer	1/31/2024	\$	69.98	2/12/2024 182428

Total 01440900702:					\$	114,044.80		
1440900802								
Life Insurance - Library	North American Benefits Company	1/22/2024	Group Term Life Insurance	1/31/2024	\$	108.00	1/30/2024	182320
Total 01440900802:					\$	108.00		
1440900902								
Health Benefits - Library	DelCo Public Schools Healthcare Trst	1/2/2024	Health Benefits	1/31/2024	\$	9,418.49	1/16/2024	182272
Total 01440900902:					\$	9,418.49		
1440901002								
Rx/Dental/Vision - Library	Express Scripts Inc	1/2/2024	Prescription Benefits	1/31/2024	\$	10.56	1/9/2024	422
Rx/Dental/Vision - Library	Express Scripts Inc	1/12/2024	Prescription Benefits	1/31/2024	\$	1,839.89	1/12/2024	426
Rx/Dental/Vision - Library	Express Scripts Inc	1/22/2024	Prescription Benefits	1/31/2024	\$	6,839.89	1/30/2024	430
Rx/Dental/Vision - Library	Express Scripts Inc	1/2/2024	Prescription Benefits	1/31/2024	\$	10.56	1/9/2024	7092
Rx/Dental/Vision - Library	Express Scripts Inc	1/2/2024	Prescription Benefits	1/31/2024	\$	(10.56)	1/9/2024	7092
Rx/Dental/Vision - Library	North American Benefits Company	1/22/2024	Long Term Civilian Disability Insurance	2/29/2024	\$	180.09	2/6/2024	182337
Total 01440901002:					\$	8,870.43		
1440902602								
Nitre Hall Maintenance	Peco Energy	12/28/2023	1500 Karakung Dr - Nitre Hall	1/31/2024	\$	545.45	1/9/2024	182256
Nitre Hall Maintenance	Aqua Pennsylvania	1/16/2024	1414 Johnson Rd - Nitre Hall	1/31/2024	\$	61.13	1/23/2024	182294
Nitre Hall Maintenance	Verizon	1/9/2024	Nitre Hall	1/31/2024	\$	61.18	1/23/2024	182308
Nitre Hall Maintenance	Peco Energy	1/29/2024	1500 Karakung Dr - Nitre Hall	2/29/2024	\$	1,128.37	2/6/2024	182339
Total 01440902602:					\$	1,796.13		
1440902702								
Federal Sch Maintenance	Peco Energy	12/28/2023	169 Allgates Dr	1/31/2024	\$	39.73	1/9/2024	182256
Federal Sch Maintenance	Aqua Pennsylvania	1/17/2024	169 Allgates Dr - Federal School	1/31/2024	\$	61.13	1/30/2024	182311
Federal Sch Maintenance	Peco Energy	1/29/2024	169 Allgates Dr	2/29/2024	\$	36.40	2/6/2024	182339
Federal Sch Maintenance	Superior Alarm Systems Inc	2/4/2024	Fire Alarm Monitoring - Federal School	1/31/2024	\$	120.00	2/12/2024	182498
Total 01440902702:					\$	257.26		
1440902802								
Grange Maintenance	Peco Energy	12/28/2023	201 Myrtle Ave - Carr Hse	1/31/2024	\$	606.03	1/9/2024	182256
Grange Maintenance	Peco Energy	12/28/2023	201 Myrtle Ave - Longbarn	1/31/2024	\$	42.84	1/9/2024	182256
Grange Maintenance	Peco Energy	12/28/2023	143 Myrtle Ave	1/31/2024	\$	1,077.83	1/9/2024	182256
Grange Maintenance	Aqua Pennsylvania	1/16/2024	ES Myrtle Ave - Grange	1/31/2024	\$	90.31	1/23/2024	182294
Grange Maintenance	Aqua Pennsylvania	1/16/2024	139 Myrtle Ave - Grange	1/31/2024	\$	105.33	1/23/2024	182294
Grange Maintenance	Constellation NewEnergy Gas Division LLC	1/25/2024	Natural Gas - 143 Myrtle Rd	1/31/2024	\$	345.31	1/30/2024	182315
Grange Maintenance	Peco Energy	1/29/2024	201 Myrtle Ave - Carr Hse	2/29/2024	\$	759.78	2/6/2024	182339
Grange Maintenance	Peco Energy	1/29/2024	201 Myrtle Ave - Longbarn	2/29/2024	\$	47.19	2/6/2024	182339
Grange Maintenance	Peco Energy	1/29/2024	143 Myrtle Ave	2/29/2024	\$	1,417.18	2/6/2024	182339
Grange Maintenance	Superior Alarm Systems Inc	1/1/2024	Fire Alarm Monitoring - 143 Myrtle	1/31/2024	\$	75.00	2/12/2024	182498
Total 01440902802:					\$	4,566.80		
1440902902								
Environmental Advisory	Plant Signs	12/11/2023	(100) Engraved Plant Signs & Stakes	12/31/2023	\$	(1,437.47)	1/17/2024	182093
Environmental Advisory	Mothers Compost LLC	1/1/2024	Hford Incentive Reporting 10/23 - 12/23	1/31/2024	\$	1,200.00	1/9/2024	182254
Environmental Advisory	Zedd360 LLC	1/1/2024	Composting (USDA Grant)	1/31/2024	\$	45.60	1/9/2024	182260
Environmental Advisory	Mothers Compost LLC	1/18/2024	Compost Workshop Speaker	1/31/2024	\$	100.00	2/12/2024	182456
Total 01440902902:					\$	(91.87)		
1440908202								
Haverford Day Expenses	Jacob Low Hardware	10/2/2023	Bit, Eye Bolt, Anchors	1/31/2024	\$	23.54	1/16/2024	182282
Total 01440908202:					\$	23.54		
1450150002								
Life Insurance	North American Benefits Company	1/22/2024	Group Term Life Insurance	1/31/2024	\$	108.00	1/30/2024	182320
Total 01450150002:					\$	108.00		
1450150502								
Health Benefits	DelCo Public Schools Healthcare Trst	1/2/2024	Health Benefits	1/31/2024	\$	15,174.24	1/16/2024	182272
Total 01450150502:					\$	15,174.24		
1450151002								
Rx/Dental/Vision/LTD	Express Scripts Inc	1/2/2024	Prescription Benefits	1/31/2024	\$	98.93	1/9/2024	422
Rx/Dental/Vision/LTD	Express Scripts Inc	1/12/2024	Prescription Benefits	1/31/2024	\$	1,694.20	1/12/2024	426
Rx/Dental/Vision/LTD	Express Scripts Inc	1/22/2024	Prescription Benefits	1/31/2024	\$	133.21	1/30/2024	430
Rx/Dental/Vision/LTD	Express Scripts Inc	1/2/2024	Prescription Benefits	1/31/2024	\$	98.93	1/9/2024	7092

Rx/Dental/Vision/LTD	Express Scripts Inc	1/2/2024	Prescription Benefits	1/31/2024	\$	(98.93)	1/9/2024	7092
Rx/Dental/Vision/LTD	Vision Benefits of America	1/5/2024	Vision Benefits	1/31/2024	\$	50.00	1/23/2024	182309
Rx/Dental/Vision/LTD	North American Benefits Company	1/22/2024	Long Term Civilian Disability Insurance	2/29/2024	\$	236.72	2/6/2024	182337
Total 01450151002:					\$	2,213.06		
1450152002								
Workers Compensation	Arthur J Gallagher Risk Mgmt Serv Inc	1/8/2024	2022 WC Audit	1/31/2024	\$	956.94	1/16/2024	182263
Total 01450152002:					\$	956.94		
1450200202								
Office Supplies	Office Basics, Inc	1/4/2024	Office Supplies	1/31/2024	\$	450.58	2/12/2024	182462
Office Supplies	Office Basics, Inc	1/4/2024	Office Supplies	1/31/2024	\$	33.16	2/12/2024	182462
Office Supplies	Office Basics, Inc	1/19/2024	Office Supplies	1/31/2024	\$	131.38	2/12/2024	182462
Office Supplies	Office Basics, Inc	1/24/2024	Office Supplies	1/31/2024	\$	382.40	2/12/2024	182462
Total 01450200202:					\$	997.52		
1450201302								
Utilities	Peco Energy	12/28/2023	9000 Parkview - Rec Ctr	1/31/2024	\$	5,206.01	1/9/2024	182256
Utilities	Aqua Pennsylvania	1/17/2024	900 Parkview Dr - Water Serv	1/31/2024	\$	309.55	1/30/2024	182311
Utilities	Peco Energy	1/29/2024	9000 Parkview - Rec Ctr	2/29/2024	\$	6,452.85	2/6/2024	182339
Total 01450201302:					\$	11,968.41		
1450210102								
Postage Expense	FP Finance Program	12/27/2023	Postage Meter Lease	1/31/2024	\$	3.75	1/9/2024	182250
Postage Expense	FP Finance Program	1/29/2024	Postage Meter Lease	2/29/2024	\$	3.75	2/6/2024	182335
Total 01450210102:					\$	7.50		
1450227002								
Program Insurance	Arthur J Gallagher Risk Mgmt Serv Inc	10/30/2023	2022 - 23 Accident Policy	1/31/2024	\$	5,261.00	1/16/2024	182263
Total 01450227002:					\$	5,261.00		
1450260002								
Assoc Dues & Membership	NRPA	1/22/2024	Membership Fee - B Barrett	1/31/2024	\$	180.00	2/12/2024	182460
Total 01450260002:					\$	180.00		
1450260202								
Training	Eileen Mottola	1/8/2024	Reimb - Ministerium Breakfast	1/31/2024	\$	60.55	1/16/2024	182274
Training	Eileen Mottola	1/22/2024	Reimb - Senior Night Out	1/31/2024	\$	157.72	1/30/2024	182317
Total 01450260202:					\$	218.27		
1450300002								
Communications	Comcast Business	1/1/2024	Cable Service	1/31/2024	\$	53.72	1/16/2024	182268
Communications	Xtel Communications, Inc	1/1/2024	Phone Expense	1/31/2024	\$	24.44	1/16/2024	182293
Communications	Comcast	1/14/2024	Cable Service - 9000 Parkview Dr BUS2	1/31/2024	\$	131.90	1/23/2024	182296
Communications	Comcast	1/14/2024	Cable Service - 9000 Parkview Dr - REC	1/31/2024	\$	655.01	1/23/2024	182297
Communications	AT & T Mobility	1/16/2024	Cellular Service	2/29/2024	\$	134.18	2/6/2024	182331
Total 01450300002:					\$	999.25		
1450400002								
Copier Lease/Maintenance	Toshiba America Business Solutions	12/25/2023	Copier Maintenance	1/31/2024	\$	176.05	1/9/2024	182258
Copier Lease/Maintenance	Toshiba Financial Service	12/28/2023	Copier Lease	1/31/2024	\$	250.89	1/9/2024	182259
Copier Lease/Maintenance	Toshiba Financial Service	1/23/2024	Copier Lease	1/31/2024	\$	250.89	1/30/2024	182326
Copier Lease/Maintenance	Toshiba America Business Solutions	1/22/2024	Copier Maintenance	2/29/2024	\$	143.71	2/6/2024	182344
Total 01450400002:					\$	821.54		
1450411702								
Vehicle Insurance	Arthur J Gallagher Risk Mgmt Serv Inc	12/18/2023	P & C Insurance Premium - 3rd Installment	1/31/2024	\$	2,000.16	1/30/2024	182312
Total 01450411702:					\$	2,000.16		
1450510002								
Vehicle Fuel	Petroleum Traders Corp	12/27/2023	Unleaded	1/31/2024	\$	202.45	2/12/2024	182473
Vehicle Fuel	Petroleum Traders Corp	1/19/2024	Unleaded	1/31/2024	\$	175.80	2/12/2024	182473
Total 01450510002:					\$	378.25		
1450922002								
Recreation Program Expense	Arbiter Sports	1/11/2024	Referees for Havertown Hoops	1/31/2024	\$	5,000.00	1/12/2024	428
Recreation Program Expense	Dana Grossi	12/14/2023	Instructor - Safe Sitter	12/31/2023	\$	(225.00)	1/24/2024	182152
Recreation Program Expense	Brian Barrett	12/28/2023	Reimb - NY Rockin Eve Refreshments	1/31/2024	\$	149.10	1/9/2024	182245
Recreation Program Expense	Carol A Fee	12/28/2023	Instructor - Zumba 12/27	1/31/2024	\$	35.00	1/9/2024	182246
Recreation Program Expense	Kevin Towell	12/29/2023	Instructor - Rockin New Years Eve Bash	1/31/2024	\$	150.00	1/9/2024	182253
Recreation Program Expense	Nicole Baker	12/29/2023	Instructor - Flow Yoga	1/31/2024	\$	100.00	1/9/2024	182255

Recreation Program Expense	Beth Ann Rush	1/8/2024	Instructor - Forever Fit Sub	1/31/2024	\$ 30.00	1/16/2024	182264
Recreation Program Expense	Caroline D Scott	1/4/2024	Instructor - Supervisor, Scorekeeper	1/31/2024	\$ 263.00	1/30/2024	182313
Recreation Program Expense	Dana Visanska	12/14/2023	Instructor - Safe Sitter	12/31/2023	\$ 225.00	1/30/2024	182316
Recreation Program Expense	Jake Ritter	1/3/2024	Instructor - Havertown Hoops	1/31/2024	\$ 535.50	1/30/2024	182319
Recreation Program Expense	Philadelphia Zoo	1/26/2024	ECP Trip - Promo BIRDS24 (#1E3DEEE57)	1/31/2024	\$ 50.00	1/30/2024	182322
Recreation Program Expense	Staci Gillespie	1/4/2024	Instructor - Havertown Hoops	1/31/2024	\$ 802.50	1/30/2024	182325
Recreation Program Expense	Arnold's Family Fun Center	2/2/2024	Deposit - ECP Trip 7/3/24	2/29/2024	\$ 250.00	2/6/2024	182330
Recreation Program Expense	Arnold's Family Fun Center	2/2/2024	Deposit - Huck Trip 7/9/2024	2/29/2024	\$ 75.00	2/6/2024	182330
Recreation Program Expense	Urban Air - Delco	2/1/2024	Deposit - Teen Adventure Trip 8/2/24	2/29/2024	\$ 322.99	2/6/2024	182345
Recreation Program Expense	Urban Air - Delco	2/1/2024	Deposit - ECP Trip 7/12/2024	2/29/2024	\$ 939.99	2/6/2024	182345
Recreation Program Expense	Urban Air - Delco	2/1/2024	Deposit - Pippi Trip 7/26/2024	2/29/2024	\$ 284.99	2/6/2024	182345
Recreation Program Expense	Aidan M Chivalette	1/25/2024	Scorekeeper - Havertown Hoops	1/31/2024	\$ 289.00	2/12/2024	182350
Recreation Program Expense	Aidan McBrearty	1/4/2024	Instructor - Rockin' New Year's Eve Bash	1/31/2024	\$ 66.00	2/12/2024	182351
Recreation Program Expense	Aidan McBrearty	1/8/2024	Instructor - Kids Night Out	1/31/2024	\$ 45.00	2/12/2024	182351
Recreation Program Expense	Allison Fineberg	2/1/2024	Instructor - Little Explorers	1/31/2024	\$ 42.00	2/12/2024	182354
Recreation Program Expense	Anthony Campese	1/9/2024	Instructor - Kids Night Out	1/31/2024	\$ 48.00	2/12/2024	182357
Recreation Program Expense	Beth Ann Rush	1/11/2024	Instructor - SS Chair Yoga The	1/31/2024	\$ 120.00	2/12/2024	182365
Recreation Program Expense	Beth Ann Rush	1/11/2024	Instructor - SS Classic Fri	1/31/2024	\$ 120.00	2/12/2024	182365
Recreation Program Expense	Beth Ann Rush	1/11/2024	Instructor - SS & Sen Chair Yoga Tue	1/31/2024	\$ 150.00	2/12/2024	182365
Recreation Program Expense	Beth Ann Rush	1/11/2024	Instructor - SS Chair Yoga Fri	1/31/2024	\$ 120.00	2/12/2024	182365
Recreation Program Expense	Beth Ann Rush	1/11/2024	Instructor - SSC & Sen Fit Mon	1/31/2024	\$ 90.00	2/12/2024	182365
Recreation Program Expense	Beth Ann Rush	1/11/2024	Instructor - Hatha Yoga Tue	1/31/2024	\$ 200.00	2/12/2024	182365
Recreation Program Expense	Brian James Bausman Jr	1/31/2024	Scorekeeper	1/31/2024	\$ 357.00	2/12/2024	182369
Recreation Program Expense	Bryce Pivovarnik	1/31/2023	Scorekeeper	1/31/2024	\$ 289.00	2/12/2024	182371
Recreation Program Expense	Bryn Mawr Racing Company	12/4/2023	Race Timing & Management - Chilly Trail Run 5K	1/31/2024	\$ 460.00	2/12/2024	182372
Recreation Program Expense	Carol A Fee	1/11/2024	Instructor - Zumba Sat	1/31/2024	\$ 140.00	2/12/2024	182374
Recreation Program Expense	Carol A Fee	1/11/2024	Instructor - Zumba Wed	1/31/2024	\$ 175.00	2/12/2024	182374
Recreation Program Expense	Caroline D Scott	1/18/2024	Instructor - Supervisor, Scorekeeper	1/31/2024	\$ 145.00	2/12/2024	182375
Recreation Program Expense	Charles E Watkins	1/11/2024	Instructor - Breathe Just Breathe	1/31/2024	\$ 140.00	2/12/2024	182377
Recreation Program Expense	Daniel Gallagher	1/31/2024	Instructor - Havertown Hoops	1/31/2024	\$ 322.50	2/12/2024	182386
Recreation Program Expense	Daniel Henry Bell	1/11/2024	Instructor - Littl Dribblers, Rockin New Years	1/31/2024	\$ 159.25	2/12/2024	182387
Recreation Program Expense	Daniel Henry Bell	1/31/2024	Instructor - Basketball Clinic	1/31/2024	\$ 57.00	2/12/2024	182387
Recreation Program Expense	Deborah Saldana	1/11/2024	Instructor - Barre	1/31/2024	\$ 120.00	2/12/2024	182389
Recreation Program Expense	Elizabeth Luff	1/11/2024	Instructor - Dancing Divas 65+	1/31/2024	\$ 200.00	2/12/2024	182400
Recreation Program Expense	Grace Baraldi	1/25/2024	Instructor - Kids Night Out	1/31/2024	\$ 45.00	2/12/2024	182412
Recreation Program Expense	Jake Ritter	1/31/2024	Instructor - Havertown Hoops	1/31/2024	\$ 548.25	2/12/2024	182429
Recreation Program Expense	Kieran Gillespie	1/31/2024	Scorekeeper	1/31/2024	\$ 425.00	2/12/2024	182436
Recreation Program Expense	Lauren DiMartino	1/11/2024	Instructor - Zumba	1/31/2024	\$ 105.00	2/12/2024	182438
Recreation Program Expense	Lisa A Drake	1/11/2024	Instructor - The Pound Workout	1/31/2024	\$ 175.00	2/12/2024	182440
Recreation Program Expense	LogoWear House Inc	12/22/2023	(19) Shirts - Havertown Hoops Staff	1/31/2024	\$ 342.00	2/12/2024	182442
Recreation Program Expense	LogoWear House Inc	12/29/2023	(151) Shirts - Chilly Trail Run	1/31/2024	\$ 1,397.75	2/12/2024	182442
Recreation Program Expense	LogoWear House Inc	1/20/2024	(26) Shirts - Haverford Twp Parks & Rec Staff	1/31/2024	\$ 491.00	2/12/2024	182442
Recreation Program Expense	Maeve Hegarty	1/3/2024	Instructor - Rockin New Years Eve Bash	1/31/2024	\$ 48.00	2/12/2024	182443
Recreation Program Expense	Mary Pat Hartline	1/11/2024	Instructor - Chair Yoga Arthritis Wed	1/31/2024	\$ 150.00	2/12/2024	182446
Recreation Program Expense	Mary Pat Hartline	1/11/2024	Instructor - Pure Stretch Mon	1/31/2024	\$ 90.00	2/12/2024	182446
Recreation Program Expense	Mason Paul	1/3/2024	Instructor - Rockin New Years Eve Bash	1/31/2024	\$ 120.00	2/12/2024	182447
Recreation Program Expense	Mason Paul	1/4/2024	Instructor - Rockin' New Years Eve Bash	1/31/2024	\$ 120.00	2/12/2024	182447
Recreation Program Expense	Mason Paul	1/9/2024	Instructor - Kids Night Out	1/31/2024	\$ 45.00	2/12/2024	182447
Recreation Program Expense	Maura Riscavage	1/3/2024	Instructor - Rockin New Years Eve Bash	1/31/2024	\$ 143.00	2/12/2024	182448
Recreation Program Expense	Maxwell J Carfrey	1/18/2024	Rentals	1/31/2024	\$ 112.00	2/12/2024	182449
Recreation Program Expense	Pi-Chi Yang	1/17/2024	Instructor - Adult Ballet	1/31/2024	\$ 140.00	2/12/2024	182475
Recreation Program Expense	PPS Print Solutions	12/21/2023	Winter 2023 HavaGood Times Newsletter	1/31/2024	\$ 11,592.65	2/12/2024	182479
Recreation Program Expense	Robert Rinaldi	1/25/2024	Instructor - Little Explorers	1/31/2024	\$ 56.00	2/12/2024	182484
Recreation Program Expense	Sandi Kirschner	1/11/2024	Instructor - Gentle Stretch & Tone Wed	1/31/2024	\$ 175.00	2/12/2024	182485
Recreation Program Expense	Sandy McGuire	1/11/2024	Instructor - Barre Thu	1/31/2024	\$ 160.00	2/12/2024	182486
Recreation Program Expense	Sandy McGuire	1/11/2024	Instructor - Cycle Sat	1/31/2024	\$ 160.00	2/12/2024	182486
Recreation Program Expense	Sandy McGuire	1/11/2024	Instructor - Cycle Tue	1/31/2024	\$ 200.00	2/12/2024	182486
Recreation Program Expense	School District of Haverford Township	1/31/2024	Manoa ES Gym Rental	1/31/2024	\$ 300.00	2/12/2024	182487
Recreation Program Expense	School District of Haverford Township	1/31/2024	Manoa ES Gym Rental	1/31/2024	\$ 480.00	2/12/2024	182487

Recreation Program Expense	School District of Haverford Township	1/31/2024	Manoa ES Gym Rental	1/31/2024	\$ 540.00	2/12/2024	182487
Recreation Program Expense	School District of Haverford Township	1/31/2024	Manoa ES Gym Rental	1/31/2024	\$ 720.00	2/12/2024	182487
Recreation Program Expense	School District of Haverford Township	1/31/2024	Coopertown ES Gym Rental	1/31/2024	\$ 760.00	2/12/2024	182487
Recreation Program Expense	School District of Haverford Township	1/31/2024	Coopertown ES Gym Rental	1/31/2024	\$ 800.00	2/12/2024	182487
Recreation Program Expense	School District of Haverford Township	1/31/2024	Chestnutwold ES Gym Rental	1/31/2024	\$ 660.00	2/12/2024	182487
Recreation Program Expense	School District of Haverford Township	1/31/2024	Chestnutwold ES Gym Rental	1/31/2024	\$ 800.00	2/12/2024	182487
Recreation Program Expense	School District of Haverford Township	1/31/2024	Manoa ES Gym Rental	1/31/2024	\$ 480.00	2/12/2024	182487
Recreation Program Expense	School District of Haverford Township	1/31/2024	Lynnewood ES Gym Rental	1/31/2024	\$ 5,250.00	2/12/2024	182487
Recreation Program Expense	Spectrum Letterbox	1/1/2024	Havagood Times Winter/Spring 2024	1/31/2024	\$ 1,795.00	2/12/2024	182493
Recreation Program Expense	Spike's Trophies Limited	11/11/2023	(32) Medals - Chilly Trail Run	1/31/2024	\$ 131.40	2/12/2024	182494
Recreation Program Expense	Staci Gillespie	1/31/2024	Instructor - Havertown Hoops	1/31/2024	\$ 1,005.00	2/12/2024	182496
Recreation Program Expense	William McKee	1/31/2024	Scorekeeper	1/31/2024	\$ 238.00	2/12/2024	182516
Total 01450922002:					\$	43,642.87	
1450923202							
Operating Expenses - CREC	Apex Elevator Inspection & Testing LLC	12/29/2023	Routine Inspection - CREC	1/31/2024	\$ 60.00	2/12/2024	182358
Operating Expenses - CREC	Franklin Cleaning Equip & Supply Co	1/9/2024	Brush Assembly, Bearing Kit	1/31/2024	\$ 293.86	2/12/2024	182408
Operating Expenses - CREC	Hillyard /Delaware Valley Inc	1/12/2024	(2) Scrubbing Pads	1/31/2024	\$ 108.40	2/12/2024	182422
Operating Expenses - CREC	Omer's Garden Center	12/13/2023	(2) Douglas Fir	1/31/2024	\$ 140.00	2/12/2024	182464
Operating Expenses - CREC	Sinclair Exterminating Inc	12/31/2023	Exterminating - CREC	1/31/2024	\$ 195.00	2/12/2024	182491
Operating Expenses - CREC	T. Frank McCall's, Inc	1/10/2024	Maintenance Items	1/31/2024	\$ 1,173.15	2/12/2024	182499
Operating Expenses - CREC	T. Frank McCall's, Inc	1/16/2024	Maintenance Items	1/31/2024	\$ 230.19	2/12/2024	182499
Operating Expenses - CREC	T. Frank McCall's, Inc	1/25/2024	Maintenance Items	1/31/2024	\$ 128.68	2/12/2024	182499
Operating Expenses - CREC	T. Frank McCall's, Inc	1/30/2024	Maintenance Items	1/31/2024	\$ 123.09	2/12/2024	182499
Operating Expenses - CREC	Tustin Water Solutions LLC	1/4/2024	Water Treatment Maint Agreeme	1/31/2024	\$ 381.00	2/12/2024	182511
Operating Expenses - CREC	W. B. Mason Co, Inc.	12/1/2023	Cleaning Supplies	1/31/2024	\$ 140.00	2/12/2024	182515
Total 01450923202:					\$	2,973.37	
1451150002							
Life Insurance	North American Benefits Company	1/22/2024	Group Term Life Insurance	1/31/2024	\$ 56.40	1/30/2024	182320
Total 01451150002:					\$	56.40	
1451150502							
Health Benefits	DelCo Public Schools Healthcare Trst	1/2/2024	Health Benefits	1/31/2024	\$ 6,099.61	1/16/2024	182272
Total 01451150502:					\$	6,099.61	
1451151002							
Rx/Dental/Vision/LTD	Express Scripts Inc	1/12/2024	Prescription Benefits	1/31/2024	\$ 112.44	1/12/2024	426
Rx/Dental/Vision/LTD	Express Scripts Inc	1/22/2024	Prescription Benefits	1/31/2024	\$ 165.88	1/30/2024	430
Rx/Dental/Vision/LTD	North American Benefits Company	1/22/2024	Long Term Civilian Disability Insurance	2/29/2024	\$ 94.24	2/6/2024	182337
Total 01451151002:					\$	372.56	
1451152002							
Workers Compensation	Arthur J Gallagher Risk Mgmt Serv Inc	1/8/2024	2022 WC Audit	1/31/2024	\$ 420.12	1/16/2024	182263
Total 01451152002:					\$	420.12	
1451200002							
Miscellaneous Expense	Rick Turnbull	1/10/2024	Skate Guard Holiday Lunch	1/31/2024	\$ 22.26	1/16/2024	182290
Total 01451200002:					\$	22.26	
1451200202							
Office Supplies	Office Basics, Inc	1/18/2024	Office Supplies	1/31/2024	\$ 75.95	2/12/2024	182462
Total 01451200202:					\$	75.95	
1451201302							
Utilities	Peco Energy	12/28/2023	1002 Darby Rd - Rear	1/31/2024	\$ 1,733.07	1/9/2024	182256
Utilities	Peco Energy	12/28/2023	Darby Rd & N Manoa Rd - Skatium	1/31/2024	\$ 12,431.63	1/9/2024	182256
Utilities	Aqua Pennsylvania	1/16/2024	1020 Darby Rd - Skatium	1/31/2024	\$ 1,900.44	1/23/2024	182294
Utilities	Constellation NewEnergy Gas Division LLC	1/25/2024	Natural Gas - 1002 Darby Rd	1/31/2024	\$ 2,432.52	1/30/2024	182315
Utilities	Peco Energy	1/29/2024	1002 Darby Rd - Rear	2/29/2024	\$ 2,036.77	2/6/2024	182339
Utilities	Peco Energy	1/29/2024	Darby Rd & N Manoa Rd - Skatium	2/29/2024	\$ 11,417.18	2/6/2024	182339
Total 01451201302:					\$	31,951.61	
1451210102							
Postage Expense	FP Finance Program	12/27/2023	Postage Meter Lease	1/31/2024	\$ 3.75	1/9/2024	182250
Postage Expense	FP Finance Program	1/29/2024	Postage Meter Lease	2/29/2024	\$ 3.75	2/6/2024	182335
Total 01451210102:					\$	7.50	
1451280302							

Uniforms Regular	Flocco Inc	8/30/2023	Work Boots	1/31/2024	\$	120.00	1/16/2024	182275
Total 01451280302:					\$	120.00		
1451300002								
Communications	Comcast	1/16/2024	Cable Service - 1018 Darby Rd	1/31/2024	\$	275.26	1/23/2024	182299
Communications	AT & T Mobility	1/16/2024	Cellular Service	2/29/2024	\$	89.46	2/6/2024	182331
Total 01451300002:					\$	364.72		
1451400002								
Copier Lease/Maintenance	Toshiba America Business Solutions	12/25/2023	Copier Maintenance	1/31/2024	\$	4.23	1/9/2024	182258
Copier Lease/Maintenance	Toshiba Financial Service	12/28/2023	Copier Lease	1/31/2024	\$	134.19	1/9/2024	182259
Copier Lease/Maintenance	Toshiba Financial Service	1/23/2024	Copier Lease	1/31/2024	\$	134.19	1/30/2024	182326
Copier Lease/Maintenance	Toshiba America Business Solutions	1/22/2024	Copier Maintenance	2/29/2024	\$	2.99	2/6/2024	182344
Total 01451400002:					\$	275.60		
1451430002								
Maintenance & Repairs	Lowe's	12/4/2023	Oil-Based Polyurethane, (10) Paint Brushes, Roller	1/31/2024	\$	115.33	1/16/2024	182284
Maintenance & Repairs	T. Frank McCall's, Inc	11/30/2023	Maintenance Items	1/31/2024	\$	50.38	1/16/2024	182292
Maintenance & Repairs	Daktronics Inc	1/27/2024	(2) AMB 7 Seg Discrete LED	1/31/2024	\$	250.00	2/12/2024	182385
Maintenance & Repairs	Elliott-Lewis	1/25/2024	Preventive Maintenance	1/31/2024	\$	2,700.00	2/12/2024	182401
Maintenance & Repairs	Hill Manufacturing Company Inc	12/14/2023	(12) Wall Blocks	1/31/2024	\$	122.27	2/12/2024	182421
Maintenance & Repairs	T. Frank McCall's, Inc	12/21/2023	Maintenance Items	1/31/2024	\$	98.60	2/12/2024	182499
Maintenance & Repairs	Tustin Mechanical Services LLC	12/28/2023	Compressor Repair - Skatium	1/31/2024	\$	541.50	2/12/2024	182510
Maintenance & Repairs	Tustin Mechanical Services LLC	1/17/2024	Service - Bolier	1/31/2024	\$	239.32	2/12/2024	182510
Total 01451430002:					\$	4,117.40		
1451511002								
Zamboni Gas/Maint/Insurance	Arthur J Gallagher Risk Mgmt Serv Inc	12/18/2023	P & C Insurance Premium â€" 3rd Installment	1/31/2024	\$	571.48	1/30/2024	182312
Zamboni Gas/Maint/Insurance	J & C Ice Technologies Inc	1/16/2024	Fuel Pump, Speed Sensor Z-1	1/31/2024	\$	556.56	2/12/2024	182427
Zamboni Gas/Maint/Insurance	Petroleum Traders Corp	12/27/2023	Unleaded	1/31/2024	\$	48.16	2/12/2024	182473
Zamboni Gas/Maint/Insurance	Petroleum Traders Corp	1/19/2024	Unleaded	1/31/2024	\$	52.05	2/12/2024	182473
Zamboni Gas/Maint/Insurance	Tri-State/Ace Knife Grinding Corp	12/20/2023	Blade sharpening	1/31/2024	\$	262.00	2/12/2024	182506
Total 01451511002:					\$	1,490.25		
1451511502								
Purchase Of Rental Skates	Riedell Shoes Inc	12/27/2023	(21) Skates, (48) Laces	1/31/2024	\$	3,712.35	2/12/2024	182483
Total 01451511502:					\$	3,712.35		
1451511602								
Instructor Expense	Cassandra Hawks	2/1/2024	Instructor	1/31/2024	\$	216.00	2/12/2024	182376
Instructor Expense	Dean S Boornazian	2/1/2024	Instructor	1/31/2024	\$	624.00	2/12/2024	182388
Instructor Expense	Jill Cosgrove	2/1/2024	Instructor	1/31/2024	\$	324.00	2/12/2024	182430
Instructor Expense	Oleg Altukhov	2/1/2024	Instructor	1/31/2024	\$	324.00	2/12/2024	182463
Total 01451511602:					\$	1,488.00		
1451511702								
Rink Equipment	Rick Turnbull	1/10/2024	Broom, Grease Gun	1/31/2024	\$	90.75	1/16/2024	182290
Rink Equipment	Fisher's Ace Hardware	12/28/2023	Drill	1/31/2024	\$	139.00	2/12/2024	182405
Total 01451511702:					\$	229.75		
1451522802								
Gate Sharing Expense	St Joseph's Preparatory School	1/8/2024	Prep Hockey PTR - SJP Gate Split Pink the Rink	1/31/2024	\$	980.00	1/16/2024	182291
Total 01451522802:					\$	980.00		
1454150002								
Life Insurance	North American Benefits Company	1/22/2024	Group Term Life Insurance	1/31/2024	\$	78.60	1/30/2024	182320
Total 01454150002:					\$	78.60		
1454150502								
Health Benefits	DelCo Public Schools Healthcare Trst	1/2/2024	Health Benefits	1/31/2024	\$	21,100.33	1/16/2024	182272
Total 01454150502:					\$	21,100.33		
1454151002								
Rx/Dental/Vision/LTD	Express Scripts Inc	1/12/2024	Prescription Benefits	1/31/2024	\$	22.01	1/12/2024	426
Rx/Dental/Vision/LTD	Express Scripts Inc	1/22/2024	Prescription Benefits	1/31/2024	\$	87.35	1/30/2024	430
Rx/Dental/Vision/LTD	North American Benefits Company	1/22/2024	Long Term Civilian Disability Insurance	2/29/2024	\$	194.10	2/6/2024	182337
Total 01454151002:					\$	303.46		
1454152002								
Workers Compensation	Arthur J Gallagher Risk Mgmt Serv Inc	1/8/2024	2022 WC Audit	1/31/2024	\$	443.46	1/16/2024	182263
Total 01454152002:					\$	443.46		

1454200002								
Miscellaneous Expense	ReadyRefresh by Nestle Inc	1/6/2024	Water Service	1/31/2024	\$	1.99	1/16/2024	182289
Miscellaneous Expense	ReadyRefresh by Nestle Inc	1/6/2024	Water Service	1/31/2024	\$	1.99	1/30/2024	182324
Miscellaneous Expense	Commonwealth of PA	12/31/2023	Pesticide License - P Hickman	1/31/2024	\$	10.00	2/12/2024	182382
Miscellaneous Expense	Pennoni Associates, Inc	2/1/2024	Noise Monitoring @ Township Parks	1/31/2024	\$	1,239.22	2/12/2024	182469
Total 01454200002:					\$	1,253.20		
1454200502								
Computer Expense	Noratek Solutions Inc	1/9/2024	Annual Playground Inspection Software	1/31/2024	\$	3,307.50	2/12/2024	182459
Total 014542000502:					\$	3,307.50		
1454201302								
Utilities for Parks	Aqua Pennsylvania	12/20/2023	519 Hillside Ave - Hilltop	1/31/2024	\$	52.96	1/9/2024	182244
Utilities for Parks	Aqua Pennsylvania	12/20/2023	304 Oxford Hill Ln - Westgate	1/31/2024	\$	40.54	1/9/2024	182244
Utilities for Parks	Aqua Pennsylvania	12/20/2023	1426 Windsor Park Ln - Westgate	1/31/2024	\$	176.07	1/9/2024	182244
Utilities for Parks	Peco Energy	12/28/2023	534 Central Ave - Hilltop Club Hse	1/31/2024	\$	170.55	1/9/2024	182256
Utilities for Parks	Peco Energy	12/28/2023	534 Central Ave	1/31/2024	\$	34.15	1/9/2024	182256
Utilities for Parks	Peco Energy	12/28/2023	1002 Darby Rd - Field Lighting	1/31/2024	\$	537.10	1/9/2024	182256
Utilities for Parks	Peco Energy	12/28/2023	Burmout Rd - Warrior Rd	1/31/2024	\$	75.04	1/9/2024	182256
Utilities for Parks	Peco Energy	12/28/2023	600 Glendale Rd - Merry Place	1/31/2024	\$	641.96	1/9/2024	182256
Utilities for Parks	Peco Energy	12/28/2023	200 Darby Rd - Llanerch Crossing	1/31/2024	\$	119.47	1/9/2024	182256
Utilities for Parks	Peco Energy	12/28/2023	Grasslyn Av - Grasslyn Park	1/31/2024	\$	16.44	1/9/2024	182256
Utilities for Parks	Peco Energy	12/28/2023	Parkview Dr - Public Light	1/31/2024	\$	2,914.65	1/9/2024	182256
Utilities for Parks	Peco Energy	12/28/2023	521 Hillside Ave - Hilltop Park	1/31/2024	\$	25.70	1/9/2024	182256
Utilities for Parks	Peco Energy	12/28/2023	Hillcrest Rd - Rear @ Woodleigh Rd	1/31/2024	\$	48.86	1/9/2024	182256
Utilities for Parks	Peco Energy	12/28/2023	Preston Av & Railroad	1/31/2024	\$	14.74	1/9/2024	182256
Utilities for Parks	Peco Energy	12/28/2023	Rose Tree Ln & Oxford Hill Ln	1/31/2024	\$	11.02	1/9/2024	182256
Utilities for Parks	Peco Energy	12/28/2023	311 Highland Av	1/31/2024	\$	14.55	1/9/2024	182256
Utilities for Parks	Peco Energy	12/28/2023	672 Ardmore Av	1/31/2024	\$	146.26	1/9/2024	182256
Utilities for Parks	Peco Energy	12/28/2023	Veterans Field 20 W Manoa Rd	1/31/2024	\$	11.02	1/9/2024	182256
Utilities for Parks	Peco Energy	12/28/2023	Washington Av - Manoa Rd	1/31/2024	\$	56.53	1/9/2024	182256
Utilities for Parks	Peco Energy	12/28/2023	Washington Av	1/31/2024	\$	30.12	1/9/2024	182256
Utilities for Parks	Peco Energy	12/28/2023	Raymond Dr - Genthart	1/31/2024	\$	29.97	1/9/2024	182256
Utilities for Parks	Aqua Pennsylvania	1/16/2024	514 St Albans Rd - Grange Field	1/31/2024	\$	35.02	1/23/2024	182294
Utilities for Parks	Aqua Pennsylvania	1/16/2024	906 Powder Mill Rd - Powder Mill	1/31/2024	\$	35.99	1/23/2024	182294
Utilities for Parks	Aqua Pennsylvania	1/16/2024	1845 Karakung Dr - Karakung	1/31/2024	\$	20.97	1/23/2024	182294
Utilities for Parks	Aqua Pennsylvania	1/16/2024	1623 Pelham Rd - Karakung	1/31/2024	\$	20.97	1/23/2024	182294
Utilities for Parks	Aqua Pennsylvania	1/16/2024	705 Myrtle Ave - Karakung	1/31/2024	\$	35.99	1/23/2024	182294
Utilities for Parks	Aqua Pennsylvania	1/16/2024	2200 Grasslyn Ave - Grasslyn	1/31/2024	\$	20.97	1/23/2024	182294
Utilities for Parks	Aqua Pennsylvania	1/23/2024	605 Washington Ave - Veterans	1/31/2024	\$	35.99	1/30/2024	182311
Utilities for Parks	Aqua Pennsylvania	1/22/2024	519 Hillside Ave - Hilltop	1/31/2024	\$	38.69	1/30/2024	182311
Utilities for Parks	Aqua Pennsylvania	1/22/2024	304 Oxford Hill Ln - Westgate	1/31/2024	\$	21.34	1/30/2024	182311
Utilities for Parks	Aqua Pennsylvania	1/17/2024	ES Merrybrook Rd - Paddock	1/31/2024	\$	31.00	1/30/2024	182311
Utilities for Parks	Aqua Pennsylvania	1/17/2024	2512 Wynnefield Dr - Merwood	1/31/2024	\$	35.99	1/30/2024	182311
Utilities for Parks	Aqua Pennsylvania	1/17/2024	660 Ardmore Ave - Elwell	1/31/2024	\$	20.97	1/30/2024	182311
Utilities for Parks	Aqua Pennsylvania	1/17/2024	721 Railroad Ave - Preston	1/31/2024	\$	20.97	1/30/2024	182311
Utilities for Parks	Aqua Pennsylvania	1/17/2024	600 Dayton Rd - Polo	1/31/2024	\$	20.97	1/30/2024	182311
Utilities for Parks	Aqua Pennsylvania	1/22/2024	1426 Windsor Park Ln - Westgate	1/31/2024	\$	104.31	1/30/2024	182311
Utilities for Parks	Aqua Pennsylvania	1/17/2024	3500 Darby Rd - Lot A-Sprinkler	1/31/2024	\$	608.20	1/30/2024	182311
Utilities for Parks	Aqua Pennsylvania	1/17/2024	3500 Darby Rd - Lot B-Sprinkler	1/31/2024	\$	167.67	1/30/2024	182311
Utilities for Parks	Aqua Pennsylvania	1/17/2024	955 Railroad Av - Polo	1/31/2024	\$	117.78	1/30/2024	182311
Utilities for Parks	Aqua Pennsylvania	1/17/2024	9001 Parkview Dr - Dog Park Line	1/31/2024	\$	20.97	1/30/2024	182311
Utilities for Parks	Aqua Pennsylvania	1/17/2024	422 W Hathaway Ln - Merwood Park	1/31/2024	\$	45.33	1/30/2024	182311
Utilities for Parks	Peco Energy	1/29/2024	534 Central Ave - Hilltop Club Hse	2/29/2024	\$	116.43	2/6/2024	182339
Utilities for Parks	Peco Energy	1/29/2024	534 Central Ave	2/29/2024	\$	35.00	2/6/2024	182339
Utilities for Parks	Peco Energy	1/29/2024	1002 Darby Rd - Field Lighting	2/29/2024	\$	280.42	2/6/2024	182339
Utilities for Parks	Peco Energy	1/29/2024	Burmout Rd - Warrior Rd	2/29/2024	\$	37.18	2/6/2024	182339
Utilities for Parks	Peco Energy	1/29/2024	600 Glendale Rd - Merry Place	2/29/2024	\$	671.86	2/6/2024	182339
Utilities for Parks	Peco Energy	1/29/2024	200 Darby Rd - Llanerch Crossing	2/29/2024	\$	78.41	2/6/2024	182339
Utilities for Parks	Peco Energy	1/29/2024	Grasslyn Av - Grasslyn Park	2/29/2024	\$	16.50	2/6/2024	182339
Utilities for Parks	Peco Energy	1/29/2024	Parkview Dr - Public Light	2/29/2024	\$	2,316.54	2/6/2024	182339

Utilities for Parks	Peco Energy	1/29/2024	521 Hillside Ave - Hilltop Park	2/29/2024	\$ 25.73	2/6/2024	182339
Utilities for Parks	Peco Energy	1/29/2024	Hillcrest Rd - Rear @ Woodleigh Rd	2/29/2024	\$ 48.53	2/6/2024	182339
Utilities for Parks	Peco Energy	1/29/2024	Preston Av & Railroad	2/29/2024	\$ 14.77	2/6/2024	182339
Utilities for Parks	Peco Energy	1/29/2024	Rose Tree Ln & Oxford Hill Ln	2/29/2024	\$ 11.05	2/6/2024	182339
Utilities for Parks	Peco Energy	1/29/2024	311 Highland Av	2/29/2024	\$ 14.57	2/6/2024	182339
Utilities for Parks	Peco Energy	1/29/2024	672 Ardmore Av	2/29/2024	\$ 81.67	2/6/2024	182339
Utilities for Parks	Peco Energy	1/29/2024	Veterans Field 20 W Manoa Rd	2/29/2024	\$ 11.05	2/6/2024	182339
Utilities for Parks	Peco Energy	1/29/2024	Washington Av - Manoa Rd	2/29/2024	\$ 56.57	2/6/2024	182339
Utilities for Parks	Peco Energy	1/29/2024	Washington Av	2/29/2024	\$ 30.12	2/6/2024	182339
Utilities for Parks	Peco Energy	1/29/2024	Raymond Dr - Genthart	2/29/2024	\$ 30.04	2/6/2024	182339
Total 01454201302:					\$	10,504.23	
1454280302							
Uniforms Regular	Flocco Inc	8/30/2023	Work Boots	1/31/2024	\$ 840.00	1/16/2024	182275
Uniforms Regular	Eastern Glove & Safety	1/17/2024	Uniforms	1/31/2024	\$ 942.81	2/12/2024	182398
Total 01454280302:					\$	1,782.81	
1454300002							
Communications	Comcast	1/8/2024	Cable Service - 597 Glendale Rd	1/31/2024	\$ 266.33	1/16/2024	182265
Communications	AT & T Mobility	1/16/2024	Cellular Service	2/29/2024	\$ 89.46	2/6/2024	182331
Total 01454300002:					\$	355.79	
1454411702							
Vehicle Insurance	Arthur J Gallagher Risk Mgmt Serv Inc	12/18/2023	P & C Insurance Premium - 3rd Installment	1/31/2024	\$ 3,200.26	1/30/2024	182312
Total 01454411702:					\$	3,200.26	
1454430102							
Maint & Repair Facilities	Lowe's	12/21/2023	REFUND - Tax	1/31/2024	\$ (7.35)	1/16/2024	182284
Maint & Repair Facilities	Lowe's	12/12/2023	Lumber, Concrete Anchors	1/31/2024	\$ 61.22	1/16/2024	182284
Maint & Repair Facilities	Lowe's	12/12/2023	RETURN - Threshold	1/31/2024	\$ (25.63)	1/16/2024	182284
Maint & Repair Facilities	Lowe's	12/12/2023	Threshold	1/31/2024	\$ 16.13	1/16/2024	182284
Maint & Repair Facilities	Lowe's	12/20/2023	Door Stop, Weatherstrip	1/31/2024	\$ 43.25	1/16/2024	182284
Maint & Repair Facilities	Lowe's	12/21/2023	Saw Blade, Caulk	1/31/2024	\$ 129.84	1/16/2024	182284
Maint & Repair Facilities	Lowe's	12/22/2023	Combined Door Knob, Fiberglass Safety Mask, Grinding Wheel	1/31/2024	\$ 140.05	1/16/2024	182284
Maint & Repair Facilities	Lowe's	12/27/2023	Galvanized Steel, Trowel, Mortor Mix	1/31/2024	\$ 45.71	1/16/2024	182284
Maint & Repair Facilities	Lowe's	12/11/2023	(2) Exterior Single-cylinder Keyed Entry Door Knob	1/31/2024	\$ 106.32	1/16/2024	182284
Maint & Repair Facilities	Lowe's	12/11/2023	(2) Door Sweeps, Concrete Anchors	1/31/2024	\$ 71.96	1/16/2024	182284
Maint & Repair Facilities	Lowe's	12/19/2023	(3) 5-Tier Utility Shelving	1/31/2024	\$ 510.15	1/16/2024	182284
Maint & Repair Facilities	Lowe's	12/5/2023	Painters Tape, Lumber, Concrete	1/31/2024	\$ 53.15	1/16/2024	182284
Maint & Repair Facilities	Lowe's	12/12/2023	RETURN - Weatherstrip	1/31/2024	\$ (16.99)	1/16/2024	182284
Maint & Repair Facilities	Lowe's	12/12/2023	Keyed Entry Door Knob, Threshold	1/31/2024	\$ 139.50	1/16/2024	182284
Maint & Repair Facilities	McLenaghan Wholesale Tires Inc	3/13/2023	(2) Tires	1/31/2024	\$ 140.00	1/16/2024	182285
Maint & Repair Facilities	Brookline Baseball & Softball	1/30/2024	Veterans Field Snack Shack	2/29/2024	\$ 300.89	2/6/2024	182332
Maint & Repair Facilities	A Marinelli & Sons Inc	1/11/2024	Concrete - Westgate	1/31/2024	\$ 111.50	2/12/2024	182349
Maint & Repair Facilities	American Swing Products Inc	1/25/2024	(10) Swing Strap Seats, (10) Tot Swing Seats	1/31/2024	\$ 2,172.00	2/12/2024	182356
Maint & Repair Facilities	American Swing Products Inc	1/30/2024	(30) Swing Hangers	1/31/2024	\$ 858.00	2/12/2024	182356
Maint & Repair Facilities	Delaware Valley Turf	12/19/2023	Prepay 2024 Seasons Application - Steel Field	1/31/2024	\$ 2,183.10	2/12/2024	182391
Maint & Repair Facilities	FencCo Inc	1/18/2024	Chain Link Fence - McDonald	1/31/2024	\$ 7,350.00	2/12/2024	182404
Maint & Repair Facilities	FencCo Inc	1/30/2024	Fencing Turf & Lower Field - Reserve Park	1/31/2024	\$ 2,223.00	2/12/2024	182404
Maint & Repair Facilities	Flag Products Inc	1/3/2024	Nylon Rope - Freedom Playground	1/31/2024	\$ 349.00	2/12/2024	182406
Maint & Repair Facilities	MG Tree LLC	12/4/2023	Tree Removal - Veterans Park	1/31/2024	\$ 700.00	2/12/2024	182452
Maint & Repair Facilities	Pioneer Manufacturing Company	1/19/2024	(6) Aerosol Chalk	1/31/2024	\$ 735.90	2/12/2024	182476
Maint & Repair Facilities	Port A Bowl Restroom Co Corp	10/6/2023	Port A Bowl Restroom - McDonald	1/31/2024	\$ 102.46	2/12/2024	182478
Maint & Repair Facilities	Port A Bowl Restroom Co Corp	12/28/2023	Port A Bowl Restroom - Freedom Playground	1/31/2024	\$ 102.46	2/12/2024	182478
Maint & Repair Facilities	Port A Bowl Restroom Co Corp	1/1/2024	Port A Bowl Restroom - Haverford Reserve	1/31/2024	\$ 102.46	2/12/2024	182478
Maint & Repair Facilities	Port A Bowl Restroom Co Corp	1/28/2024	Port A Bowl Restroom - Freedom Playground	1/31/2024	\$ 102.46	2/12/2024	182478
Maint & Repair Facilities	Port A Bowl Restroom Co Corp	2/1/2024	Port A Bowl Restroom - Reserve	1/31/2024	\$ 102.46	2/12/2024	182478
Maint & Repair Facilities	Super Fence Company	1/31/2024	Install Chain Link Fence - Karakung	1/31/2024	\$ 1,250.00	2/12/2024	182497
Maint & Repair Facilities	Zeager Bros., Inc	12/26/2023	Wood Carpet	1/31/2024	\$ 2,800.50	2/12/2024	182520
Maint & Repair Facilities	Zeager Bros., Inc	1/4/2024	Woodcarpet	1/31/2024	\$ 3,043.38	2/12/2024	182520
Maint & Repair Facilities	Zeager Bros., Inc	1/11/2024	Woodcarpet	1/31/2024	\$ 3,222.38	2/12/2024	182520
Total 01454430102:					\$	29,219.26	
1454510002							

Engineering Fees	Pennoni Associates, Inc	2/1/2024	Landfill @ Maintenance Yard	1/31/2024	\$ 610.00	2/12/2024	19599
Total 08429290402:					\$ 610.00		
8429300002							
Communications	AT & T Mobility	1/16/2024	Cellular Service	2/29/2024	\$ 89.46	2/6/2024	19587
Communications	Pennsylvania One Call System Inc	12/31/2023	Emergency phone srvc	1/31/2024	\$ 199.30	2/12/2024	19600
Total 08429300002:					\$ 288.76		
8429410802							
General Liability Insurance	Arthur J Gallagher Risk Mgmt Serv Inc	12/18/2023	P & C Insurance Premium â€“ 3rd Installment	1/31/2024	\$ 2,949.50	1/30/2024	19585
Total 08429410802:					\$ 2,949.50		
8429411702							
Vehicle Insurance	Arthur J Gallagher Risk Mgmt Serv Inc	12/18/2023	P & C Insurance Premium â€“ 3rd Installment	1/31/2024	\$ 3,200.26	1/30/2024	19585
Total 08429411702:					\$ 3,200.26		
8429510002							
Vehicle Fuel	Petroleum Traders Corp	12/27/2023	Unleaded	1/31/2024	\$ 888.55	2/12/2024	19601
Vehicle Fuel	Petroleum Traders Corp	12/27/2023	Unleaded	1/31/2024	\$ 652.35	2/12/2024	19601
Vehicle Fuel	Petroleum Traders Corp	1/19/2024	Unleaded	1/31/2024	\$ 771.57	2/12/2024	19601
Vehicle Fuel	Petroleum Traders Corp	1/19/2024	Unleaded	1/31/2024	\$ 566.47	2/12/2024	19601
Vehicle Fuel	School District of Haverford Township	1/29/2024	Diesel Fuel	1/31/2024	\$ 480.51	2/12/2024	19602
Total 08429510002:					\$ 3,359.45		
8429510702							
Vehicle Maintenance	H A DeHart & Son	1/10/2024	Hose Assy SE-72	1/31/2024	\$ 333.90	2/12/2024	19594
Vehicle Maintenance	Imperial Supplies LLC	1/2/2024	(4) Hand Cleaners, ABS Coil, (20) Cut Off Wheels	1/31/2024	\$ 438.78	2/12/2024	19596
Vehicle Maintenance	Linde Gas & Equipment Inc	1/4/2024	Cylinder Rental	1/31/2024	\$ 266.52	2/12/2024	19598
Total 08429510702:					\$ 1,039.20		
8429600002							
Minor Equipment	Linde Gas & Equipment Inc	1/23/2024	Cylinder Rental	1/31/2024	\$ 220.59	2/12/2024	19598
Total 08429600002:					\$ 220.59		
Total Sewer Fund::					\$ 214,974.93		
Grand Totals:					\$ 3,048,768.23		

Haverford Township
 Check Register - January 9, 2024 thru February 12, 2024
 (Formatted for ADA Accessibility)

Check Issue Date	Check Number	Payee	Amount
American Rescue Plan - PLGIT			
1/9/2024	7091	Christine Fanelli	\$ 500.00
1/16/2024	7094	Julio S. Paz Y Mino	\$ 500.00
1/16/2024	7095	LogoWear House Inc	\$ 980.00
1/23/2024	7096	Edward Konieczny	\$ 500.00
1/29/2024	7097	Maryann Dugan	\$ - V
1/29/2024	7098	Scott Selkowitz	\$ - V
1/30/2024	7099	Maryann Dugan	\$ 500.00
1/30/2024	7100	Scott Selkowitz	\$ 80.62
2/6/2024	7101	Dolores E Brough	\$ 500.00
2/12/2024	7102	All Seasons Landscaping Co. Inc.	\$ 21,490.00
2/12/2024	7103	Element Environmental Solutions Inc	\$ 2,665.00
2/12/2024	7104	FencCo Inc	\$ 11,000.00
2/12/2024	7105	N Abbonizio Contractors, Inc	\$ 23,516.08
2/12/2024	7106	Penndot	\$ 140.00
2/12/2024	7107	Pennoni Associates, Inc	\$ 20,893.35
Total American Rescue Plan Fund:			\$ 83,265.05
2018 GO Bond - PLGIT			
2/12/2024	1138	Pennoni Associates, Inc	\$ 3,441.25 M
2023 GO Bond Series A - PLGIT			
1/16/2024	8055	Flag Products Inc	\$ 3,589.50
2/12/2024	8056	AJM Electric, Inc	\$ 17,775.00
2/12/2024	8057	Bernardon Architects	\$ 6,241.36
2/12/2024	8058	Bristol Environmental inc	\$ 12,300.00
2/12/2024	8059	C.B. Development Services, Inc	\$ 63,900.00
2/12/2024	8060	Corcoran Drilling Co Inc	\$ 1,950.00
2/12/2024	8061	David Blackmore & Associates Inc	\$ 4,698.48
2/12/2024	8062	Delaware County Intermediate Unit	\$ 12,754.08
2/12/2024	8063	Dolan Mechanical, Inc	\$ 124,135.20
2/12/2024	8064	Element Environmental Solutions Inc	\$ 8,607.85
2/12/2024	8065	Excel Elevator & Escalator LLC	\$ 850.00
2/12/2024	8066	Keystone Municipal Services, Inc	\$ 37.50
2/12/2024	8067	Pennoni Associates, Inc	\$ 848.75
2/12/2024	8068	Rycon Construction, Inc	\$ 164,159.78
2/12/2024	8069	Spidernet Technical Consulting, LLC	\$ 11,725.65
2023 GO Bond Series B - PLGIT			
2/12/2024	7016	McCloskey Mechanical Contractors, Inc	\$ 67,321.80
2/12/2024	7017	Pennoni Associates, Inc	\$ 5,806.75
2/12/2024	7018	Schipsi Electric, LLC	\$ 5,492.70
Capital Projects - PLGIT			
1/16/2024	1415	Richard E Pierson Construction Inc	\$ 96,590.05
1/16/2024	1416	Traffic Planning and Design, Inc	\$ 17,420.30
2/12/2024	1417	CDW Government Inc	\$ 13,115.50
2/12/2024	1418	Herbert Rowland and Grubic, Inc	\$ 3,757.22
2/12/2024	1419	Michael Baker International, Inc	\$ 12,364.98
2/12/2024	1420	Pennoni Associates, Inc	\$ 8,173.75

2/12/2024	1421	Signal Service, Inc	\$	14,887.40
2/12/2024	1422	Wiss, Janney, Elstner Associates, Inc.	\$	1,797.40
Total Capital Fund:			\$	683,742.25

CDBG Cash - Operating

1/9/2024	4770	Pennoni Associates, Inc	\$	981.60
1/9/2024	4771	S.B. Conrad, Inc	\$	7,040.00
2/12/2024	4772	AJP Contractors Inc	\$	2,700.00
2/12/2024	4773	Anthony J Dunleavy Assoc Inc	\$	25,000.00
2/12/2024	4774	Leadco Environmental Services Inc	\$	1,759.00
2/12/2024	4775	Pennoni Associates, Inc	\$	1,351.15
2/12/2024	4776	Surrey Services for Seniors	\$	5,513.00
Total CDBG Grant Fund:			\$	44,344.81

General Operating

1/12/2024	424	PA Dept of Labor & Industry	\$	2,782.19	M
1/12/2024	428	Arbiter Sports	\$	5,000.00	M
1/17/2024	182093	Plant Signs	\$	(1,437.47)	V
1/24/2024	182152	Dana Grossi	\$	(225.00)	V
1/9/2024	182244	Aqua Pennsylvania	\$	605.48	
1/9/2024	182245	Brian Barrett	\$	149.10	
1/9/2024	182246	Carol A Fee	\$	35.00	
1/9/2024	182247	Dallas Data Systems Inc	\$	9,401.00	
1/9/2024	182248	DCTA	\$	10.00	
1/9/2024	182249	Delaware Cty Police Chief's Association	\$	375.00	
1/9/2024	182250	FP Finance Program	\$	125.00	
1/9/2024	182251	J & J Landscaping Management, LLC	\$	1,930.00	
1/9/2024	182252	James McCans	\$	691.97	
1/9/2024	182253	Kevin Towell	\$	150.00	
1/9/2024	182254	Mothers Compost LLC	\$	1,200.00	
1/9/2024	182255	Nicole Baker	\$	100.00	
1/9/2024	182256	Peco Energy	\$	66,718.23	
1/9/2024	182257	Robert Sandy	\$	254.41	
1/9/2024	182258	Toshiba America Business Solutions	\$	432.29	
1/9/2024	182259	Toshiba Financial Service	\$	1,265.47	
1/9/2024	182260	Zedd360 LLC	\$	45.60	
1/16/2024	182261	APMM	\$	400.00	
1/16/2024	182262	Aqua Pennsylvania	\$	46,730.91	
1/16/2024	182263	Arthur J Gallagher Risk Mgmt Serv Inc	\$	31,139.60	
1/16/2024	182264	Beth Ann Rush	\$	30.00	
1/16/2024	182265	Comcast	\$	266.33	
1/16/2024	182266	Comcast	\$	198.76	
1/16/2024	182267	Comcast	\$	383.27	
1/16/2024	182268	Comcast Business	\$	1,627.99	
1/16/2024	182269	Dawn Griffin	\$	675.00	
1/16/2024	182270	Deborah Tori	\$	56.62	
1/22/2024	182271	Delaware County Fraternal Order of	\$	-	V
1/16/2024	182272	DelCo Public Schools Healthcare Trst	\$	368,179.46	
1/16/2024	182273	Diane M Hannold	\$	81.34	
1/16/2024	182274	Eileen Mottola	\$	60.55	
1/16/2024	182275	Flocco Inc	\$	8,731.00	
1/16/2024	182276	Independence Blue Cross	\$	4,321.80	
1/16/2024	182277	Independence Blue Cross	\$	5,868.27	

1/16/2024	182278	Independence Blue Cross	\$	1,658.22
1/16/2024	182279	Independence Blue Cross	\$	5,868.27
1/16/2024	182280	Independence Blue Cross	\$	4,561.90
1/16/2024	182281	Independence Blue Cross	\$	1,658.22
1/16/2024	182282	Jacob Low Hardware	\$	23.54
1/16/2024	182283	Kate D'Arcy Edmiston	\$	150.00
1/16/2024	182284	Lowe's	\$	1,411.58
1/16/2024	182285	McLenaghan Wholesale Tires Inc	\$	140.00
1/16/2024	182286	MLH Occupational & Travel Health	\$	212.00
1/16/2024	182287	Oakmont Fire Company	\$	742.50
1/16/2024	182288	Peco Energy	\$	1,204.82
1/16/2024	182289	ReadyRefresh by Nestle Inc	\$	157.27
1/16/2024	182290	Rick Turnbull	\$	113.01
1/16/2024	182291	St Joseph's Preparatory School	\$	980.00
1/16/2024	182292	T. Frank McCall's, Inc	\$	50.38
1/16/2024	182293	Xtel Communications, Inc	\$	740.49
1/23/2024	182294	Aqua Pennsylvania	\$	3,054.74
1/23/2024	182295	Ascendance Truck LLC	\$	107,983.00
1/23/2024	182296	Comcast	\$	131.90
1/23/2024	182297	Comcast	\$	655.01
1/23/2024	182298	Comcast	\$	153.66
1/23/2024	182299	Comcast	\$	275.26
1/23/2024	182300	Comcast	\$	156.85
1/23/2024	182301	Federal Express Corp	\$	189.78
1/23/2024	182302	Foley Inc	\$	9,302.00
1/23/2024	182303	GranTurk Equipment Company Inc	\$	93,664.50
1/23/2024	182304	Office Basics, Inc	\$	329.94
1/23/2024	182305	Petty Cash - Haverford Township	\$	300.00
1/23/2024	182306	ReadyRefresh by Nestle Inc	\$	300.91
1/23/2024	182307	Strassheim Digital Imaging	\$	3,851.61
1/23/2024	182308	Verizon	\$	61.18
1/23/2024	182309	Vision Benefits of America	\$	605.88
1/26/2024	182310	Postmaster	\$	10,595.81
1/30/2024	182311	Aqua Pennsylvania	\$	2,161.89
1/30/2024	182312	Arthur J Gallagher Risk Mgmt Serv Inc	\$	112,948.44
1/30/2024	182313	Caroline D Scott	\$	263.00
1/30/2024	182314	Comcast	\$	321.92
1/30/2024	182315	Constellation NewEnergy Gas Division LLC	\$	4,501.24
1/30/2024	182316	Dana Visanska	\$	225.00
1/30/2024	182317	Eileen Mottola	\$	157.72
1/30/2024	182318	Imperial Dade	\$	2,399.23
1/30/2024	182319	Jake Ritter	\$	535.50
1/30/2024	182320	North American Benefits Company	\$	4,702.90
1/30/2024	182321	PA DEP	\$	100.00
1/30/2024	182322	Philadelphia Zoo	\$	50.00
1/30/2024	182323	Rachel Loev	\$	22.00
1/30/2024	182324	ReadyRefresh by Nestle Inc	\$	1.99
1/30/2024	182325	Staci Gillespie	\$	802.50
1/30/2024	182326	Toshiba Financial Service	\$	1,265.47
1/30/2024	182327	Tree Authority LLC	\$	1,257.00
1/30/2024	182328	Vision Benefits of America	\$	112.00
2/6/2024	182329	Andrew Payne	\$	45.00
2/6/2024	182330	Arnold's Family Fun Center	\$	325.00

2/6/2024	182331	AT & T Mobility	\$	5,188.46
2/6/2024	182332	Brookline Baseball & Softball	\$	300.89
2/6/2024	182333	City Wide Facility Solutions	\$	2,000.00
2/6/2024	182334	Federal Express Corp	\$	52.15
2/6/2024	182335	FP Finance Program	\$	125.00
2/6/2024	182336	Llanerch Diner	\$	251.85
2/6/2024	182337	North American Benefits Company	\$	3,065.12
2/6/2024	182338	Patrick McNelis	\$	78.00
2/6/2024	182339	Peco Energy	\$	69,262.10
2/6/2024	182340	Pennsylvania State Assoc. of Boroughs	\$	30.00
2/6/2024	182341	Petty Cash - Haverford Township	\$	67.28
2/6/2024	182342	Shred Patrol LLC	\$	275.00
2/6/2024	182343	Suzanne Guelli	\$	100.00
2/6/2024	182344	Toshiba America Business Solutions	\$	323.06
2/6/2024	182345	Urban Air - Delco	\$	1,547.97
2/12/2024	182346	21st Century Media-Philly Cluster	\$	2,540.75
2/12/2024	182347	911 Safety Equipment LLC	\$	150.00
2/12/2024	182348	95 Signs Inc	\$	850.00
2/12/2024	182349	A Marinelli & Sons Inc	\$	2,746.00
2/12/2024	182350	Aidan M Chivalette	\$	289.00
2/12/2024	182351	Aidan McBrearty	\$	111.00
2/12/2024	182352	A-Jon Construction Inc	\$	234.00
2/12/2024	182353	All Traffic Solutions, Inc.	\$	5,500.00
2/12/2024	182354	Allison Fineberg	\$	42.00
2/12/2024	182355	American Biosoils & Compost LLC	\$	17,334.76
2/12/2024	182356	American Swing Products Inc	\$	3,030.00
2/12/2024	182357	Anthony Campese	\$	48.00
2/12/2024	182358	Apex Elevator Inspection & Testing LLC	\$	60.00
2/12/2024	182359	Ardmore Tire Inc	\$	5,200.16
2/12/2024	182360	Arlene M. LaRosa, RPR	\$	397.00
2/12/2024	182361	Ascendance Truck Pennsylvania LLC	\$	89,758.00
2/12/2024	182362	Atlantic Tactical	\$	41.99
2/12/2024	182363	Baltimore County Police Foundation Inc	\$	1,100.00
2/12/2024	182364	Berrodin Parts Warehouse	\$	563.43
2/12/2024	182365	Beth Ann Rush	\$	800.00
2/12/2024	182366	BFI-King Of Prussia Recyclery	\$	36,005.27
2/12/2024	182367	Bird Control Services Inc	\$	102.00
2/12/2024	182368	Bound Tree Medical LLC	\$	176.93
2/12/2024	182369	Brian James Bausman Jr	\$	357.00
2/12/2024	182370	Bridgee Bees Floral Creations LLC	\$	70.00
2/12/2024	182371	Bryce Pivovarnik	\$	289.00
2/12/2024	182372	Bryn Mawr Racing Company	\$	460.00
2/12/2024	182373	Cardone-Nuss Printing	\$	628.50
2/12/2024	182374	Carol A Fee	\$	315.00
2/12/2024	182375	Caroline D Scott	\$	145.00
2/12/2024	182376	Cassandra Hawks	\$	216.00
2/12/2024	182377	Charles E Watkins	\$	140.00
2/12/2024	182378	Cherry Valley Tractor Sales	\$	445.57
2/12/2024	182379	Church's Auto Parts	\$	426.76
2/12/2024	182380	City Wide Facility Solutions	\$	1,881.10
2/12/2024	182381	Clearnetwork Inc	\$	452.54
2/12/2024	182382	Commonwealth of PA	\$	10.00
2/12/2024	182383	CooperUniversity Physicians	\$	350.00

2/12/2024	182384	D M I Home Supply	\$	518.00
2/12/2024	182385	Daktronics Inc	\$	250.00
2/12/2024	182386	Daniel Gallagher	\$	322.50
2/12/2024	182387	Daniel Henry Bell	\$	216.25
2/12/2024	182388	Dean S Boornazian	\$	624.00
2/12/2024	182389	Deborah Saldana	\$	120.00
2/12/2024	182390	Delaware County Solid Waste Authority	\$	107,872.01
2/12/2024	182391	Delaware Valley Turf	\$	2,183.10
2/12/2024	182392	Del-Val International Trucks, Inc	\$	20,035.20
2/12/2024	182393	Direct Paint & Collision Inc	\$	5,978.12
2/12/2024	182394	Discover Haverford	\$	26,908.75
2/12/2024	182395	Drugscan, Inc	\$	705.00
2/12/2024	182396	Eagle Contracting & Landscaping, Inc	\$	9,240.00
2/12/2024	182397	Eagle Wireless Communications LLC	\$	1,146.17
2/12/2024	182398	Eastern Glove & Safety	\$	942.81
2/12/2024	182399	Eastern Salt Company Inc	\$	5,119.08
2/12/2024	182400	Elizabeth Luff	\$	200.00
2/12/2024	182401	Elliott-Lewis	\$	2,700.00
2/12/2024	182402	Emblem Enterprises, Inc	\$	2,685.01
2/12/2024	182403	FBI-LEEDA	\$	100.00
2/12/2024	182404	FencCo Inc	\$	9,573.00
2/12/2024	182405	Fisher's Ace Hardware	\$	233.96
2/12/2024	182406	Flag Products Inc	\$	349.00
2/12/2024	182407	Flamm Walton Heimbach	\$	169.94
2/12/2024	182408	Franklin Cleaning Equip & Supply Co	\$	293.86
2/12/2024	182409	Gail Stickney	\$	157.26
2/12/2024	182410	Galantino Supply Company Inc	\$	1,310.50
2/12/2024	182411	General Code	\$	2,350.00
2/12/2024	182412	Grace Baraldi	\$	45.00
2/12/2024	182413	Grainger	\$	644.37
2/12/2024	182414	GranTurk Equipment Company Inc	\$	5,799.55
2/12/2024	182415	Guidemark Inc	\$	2,800.00
2/12/2024	182416	H A DeHart & Son	\$	79,985.00
2/12/2024	182417	Haverford Township Free Library	\$	111,692.34
2/12/2024	182418	Havis Inc	\$	40,489.10
2/12/2024	182419	Health Advocate Solutions Inc	\$	1,420.80
2/12/2024	182420	Hill Buick GMC	\$	9,468.07
2/12/2024	182421	Hill Manufacturing Company Inc	\$	122.27
2/12/2024	182422	Hillyard /Delaware Valley Inc	\$	108.40
2/12/2024	182423	Hockeytown 19083 LLC	\$	188.00
2/12/2024	182424	Human Relations Media	\$	481.43
2/12/2024	182425	IACP	\$	950.00
2/12/2024	182426	Imperial Supplies LLC	\$	112.23
2/12/2024	182427	J & C Ice Technologies Inc	\$	556.56
2/12/2024	182428	Jacob Low Hardware	\$	69.98
2/12/2024	182429	Jake Ritter	\$	548.25
2/12/2024	182430	Jill Cosgrove	\$	324.00
2/12/2024	182431	Joe's Automotive	\$	120.00
2/12/2024	182432	JPS Equipment Co., Inc	\$	5,459.00
2/12/2024	182433	K & S Towing & Recovery Inc	\$	678.00
2/12/2024	182434	Kelly Industrial Supply	\$	2,278.02
2/12/2024	182435	Keystone Municipal Services, Inc	\$	18,672.50
2/12/2024	182436	Kieran Gillespie	\$	425.00

2/12/2024	182437	Kilkenny Law, LLC	\$	9,653.75
2/12/2024	182438	Lauren DiMartino	\$	105.00
2/12/2024	182439	Linde Gas & Equipment Inc	\$	214.07
2/12/2024	182440	Lisa A Drake	\$	175.00
2/12/2024	182441	Little's	\$	489.80
2/12/2024	182442	LogoWear House Inc	\$	2,230.75
2/12/2024	182443	Maeve Hegarty	\$	48.00
2/12/2024	182444	Main Line Mower-Tree Care Supplies	\$	756.31
2/12/2024	182445	Manoa Cleaners, Inc	\$	946.35
2/12/2024	182446	Mary Pat Hartline	\$	240.00
2/12/2024	182447	Mason Paul	\$	285.00
2/12/2024	182448	Maura Riscavage	\$	143.00
2/12/2024	182449	Maxwell J Carfrey	\$	112.00
2/12/2024	182450	McLenaghan Wholesale Tires Inc	\$	1,713.00
2/12/2024	182451	McNichol, Byrne, & Matlawski, PC	\$	1,365.00
2/12/2024	182452	MG Tree LLC	\$	700.00
2/12/2024	182453	Mickey's Suburban Alignment Inc	\$	157.50
2/12/2024	182454	MLH Occupational & Travel Health	\$	106.00
2/12/2024	182455	MMJM Enterprises LLC	\$	1,189.60
2/12/2024	182456	Mothers Compost LLC	\$	100.00
2/12/2024	182457	National Tactical Officers Association	\$	35.00
2/12/2024	182458	Nichols Plumbing & Heating, Inc	\$	200.00
2/12/2024	182459	Noratek Solutions Inc	\$	3,307.50
2/12/2024	182460	NRPA	\$	180.00
2/12/2024	182461	Nuss Printing Inc	\$	450.50
2/12/2024	182462	Office Basics, Inc	\$	4,104.88
2/12/2024	182463	Oleg Altukhov	\$	324.00
2/12/2024	182464	Orner's Garden Center	\$	140.00
2/12/2024	182465	PA Chiefs of Police Association	\$	300.00
2/12/2024	182466	Pacifico Marple Ford	\$	9,032.94
2/12/2024	182467	Park's Best Car Wash Inc	\$	540.00
2/12/2024	182468	Penn Power Group	\$	631.17
2/12/2024	182469	Pennoni Associates, Inc	\$	5,015.22
2/12/2024	182470	PeopleGuru Inc	\$	2,231.58
2/12/2024	182471	Personal Protection Consultants inc	\$	1,794.00
2/12/2024	182472	PetroChoice	\$	9,291.52
2/12/2024	182473	Petroleum Traders Corp	\$	24,328.93
2/12/2024	182474	PetSmart #1804	\$	155.97
2/12/2024	182475	Pi-Chi Yang	\$	140.00
2/12/2024	182476	Pioneer Manufacturing Company	\$	735.90
2/12/2024	182477	Police Chiefs Assoc. of Southeastern Pa	\$	75.00
2/12/2024	182478	Port A Bowl Restroom Co Corp	\$	512.30
2/12/2024	182479	PPS Print Solutions	\$	11,592.65
2/12/2024	182480	Qualification Targets Inc	\$	450.84
2/12/2024	182481	R.S. Sales & Service, Inc	\$	576.00
2/12/2024	182482	Raffaele & Puppio, LLP	\$	2,951.00
2/12/2024	182483	Riedell Shoes Inc	\$	3,712.35
2/12/2024	182484	Robert Rinaldi	\$	56.00
2/12/2024	182485	Sandi Kirschner	\$	175.00
2/12/2024	182486	Sandy McGuire	\$	520.00
2/12/2024	182487	School District of Haverford Township	\$	10,790.00
2/12/2024	182488	School District of Haverford Township	\$	28,473.40
2/12/2024	182489	Schwaab Inc	\$	222.99

2/12/2024	182490	Signal Service, Inc	\$	9,143.50	
2/12/2024	182491	Sinclair Exterminating Inc	\$	690.00	
2/12/2024	182492	Sir Speedy Printing Center #7099	\$	2,428.00	
2/12/2024	182493	Spectrum Letterbox	\$	7,790.00	
2/12/2024	182494	Spike's Trophies Limited	\$	226.40	
2/12/2024	182495	St Jude Shop Inc	\$	43.00	
2/12/2024	182496	Staci Gillespie	\$	1,005.00	
2/12/2024	182497	Super Fence Company	\$	1,250.00	
2/12/2024	182498	Superior Alarm Systems Inc	\$	540.00	
2/12/2024	182499	T. Frank McCall's, Inc	\$	3,554.57	
2/12/2024	182500	Taddeo's Greenhouse Inc	\$	120.00	
2/12/2024	182501	Tedder Industries LLC	\$	863.55	
2/12/2024	182502	Thomson Reuters-West	\$	316.33	
2/12/2024	182503	Tri County Canine, LLC	\$	150.00	
2/12/2024	182504	Triple R Truck Parts	\$	2,326.63	
2/12/2024	182505	Tri-State Financial Group LLC	\$	6,110.97	
2/12/2024	182506	Tri-State/Ace Knife Grinding Corp	\$	262.00	
2/12/2024	182507	TruckPro LLC Corp	\$	4,271.33	
2/12/2024	182508	Turtle & Hughes, Inc	\$	2,672.25	
2/12/2024	182509	Tustin Energy Solutions, LLC	\$	2,050.00	
2/12/2024	182510	Tustin Mechanical Services LLC	\$	3,553.99	
2/12/2024	182511	Tustin Water Solutions LLC	\$	381.00	
2/12/2024	182512	ULINE, Inc	\$	105.37	
2/12/2024	182513	VCA Wellington Animal Hospital	\$	357.30	
2/12/2024	182514	Victory Gardens Inc	\$	800.00	
2/12/2024	182515	W. B. Mason Co, Inc.	\$	140.00	
2/12/2024	182516	William McKee	\$	238.00	
2/12/2024	182517	Witmer Public Safety Group Inc	\$	4,228.11	
2/12/2024	182518	YCG Inc	\$	3,341.75	
2/12/2024	182519	Yearsley's Service, Ltd	\$	14.00	
2/12/2024	182520	Zeager Bros., Inc	\$	9,066.26	
Investment - PLGIT					
1/9/2024	421	Express Scripts Inc	\$	834.80	M
1/9/2024	422	Express Scripts Inc	\$	38,596.44	M
1/12/2024	425	Express Scripts Inc	\$	3.00	M
1/12/2024	426	Express Scripts Inc	\$	52,689.69	M
1/30/2024	429	Express Scripts Inc	\$	17.50	M
1/30/2024	430	Express Scripts Inc	\$	34,967.45	M
1/9/2024	7092	Express Scripts Inc	\$	-	V
1/9/2024	7093	Express Scripts Inc	\$	-	V
Total General Fund:			\$	2,022,441.19	
Investment - Sewer PLGIT					
1/9/2024	423	Express Scripts Inc	\$	3,936.14	M
1/12/2024	427	Express Scripts Inc	\$	65.47	M
1/30/2024	431	Express Scripts Inc	\$	2.32	M
Sewer Cash - Operating					
1/16/2024	19581	Arthur J Gallagher Risk Mgmt Serv Inc	\$	233.40	
1/16/2024	19582	DelCo Public Schools Healthcare Trst	\$	9,519.55	
1/16/2024	19583	Flocco Inc	\$	800.00	
1/23/2024	19584	Vision Benefits of America	\$	195.70	
1/30/2024	19585	Arthur J Gallagher Risk Mgmt Serv Inc	\$	6,149.76	
1/30/2024	19586	North American Benefits Company	\$	64.80	

2/6/2024	19587	AT & T Mobility	\$	89.46
2/6/2024	19588	North American Benefits Company	\$	113.55
2/12/2024	19589	A Marinelli & Sons Inc	\$	822.00
2/12/2024	19590	Bullen Companies Inc	\$	1,094.86
2/12/2024	19591	Cawley Environmental Services Inc	\$	4,755.35
2/12/2024	19592	Eagle Contracting & Landscaping, Inc	\$	35,600.00
2/12/2024	19593	Galantino Supply Company Inc	\$	28.50
2/12/2024	19594	H A DeHart & Son	\$	333.90
2/12/2024	19595	Hilltop Distributors Co	\$	956.73
2/12/2024	19596	Imperial Supplies LLC	\$	438.78
2/12/2024	19597	Kilkenny Law, LLC	\$	503.75
2/12/2024	19598	Linde Gas & Equipment Inc	\$	487.11
2/12/2024	19599	Pennoni Associates, Inc	\$	1,262.50
2/12/2024	19600	Pennsylvania One Call System Inc	\$	199.30
2/12/2024	19601	Petroleum Traders Corp	\$	2,878.94
2/12/2024	19602	School District of Haverford Township	\$	480.51
2/12/2024	19603	Upper Darby Township Municipal Building	\$	1,920.87
2/12/2024	19604	Upper Darby Township Municipal Building	\$	142,041.68
Total Sewer Fund:			\$	214,974.93
Grand Totals:			\$	3,048,768.23

Haverford Township
 Gross Payroll Dated January 18 2024
 (Imported from Paychex Payroll Service and formatted for ADA Accessibility)

Department	Total Earnings	Total ER Taxes	Total Labor Cost
400 Administration	\$ 15,784.90	\$ 1,168.29	\$ 16,953.19
402 Finance	\$ 16,405.47	\$ 1,221.61	\$ 17,627.08
406 Human Resources	\$ 6,325.39	\$ 483.90	\$ 6,809.29
407 Info Technology	\$ 12,104.10	\$ 893.70	\$ 12,997.80
409 Facilities	\$ 18,572.65	\$ 1,383.76	\$ 19,956.41
410 Police	\$ 475,361.89	\$ 8,618.68	\$ 483,980.57
412 EMS Administration	\$ 9,636.02	\$ 712.24	\$ 10,348.26
413 Code Enforcement	\$ 24,702.11	\$ 1,841.45	\$ 26,543.56
416 Comm Development	\$ 3,044.84	\$ 226.79	\$ 3,271.63
427 Sanitation	\$ 80,089.12	\$ 5,973.51	\$ 86,062.63
429 Sewer Operations	\$ 18,074.21	\$ 1,348.30	\$ 19,422.51
430 PW Highways	\$ 108,907.70	\$ 8,125.17	\$ 117,032.87
450 Parks and Recreation	\$ 45,393.99	\$ 3,402.35	\$ 48,796.34
451 Ice Rink	\$ 20,855.44	\$ 1,567.86	\$ 22,423.30
454 Parks Maintenance	\$ 30,379.56	\$ 2,265.84	\$ 32,645.40
Totals	\$ 885,637.39	\$ 39,233.45	\$ 924,870.84
		Less:Noncash Fringe	\$ (2,878.08)
			\$ 921,992.76
		Sewer Fund	\$ 19,422.51
		General Fund	\$ 902,570.25

Haverford Township
 Gross Payroll Dated February 1 2024
 (Imported from Paychex Payroll Service and formatted for ADA Accessibility)

Department	Total Earnings	Total ER Taxes	Total Labor Cost
400 Administration	\$ 15,257.56	\$ 1,127.95	\$ 16,385.51
402 Finance	\$ 14,873.97	\$ 1,104.45	\$ 15,978.42
406 Human Resources	\$ 6,325.39	\$ 483.90	\$ 6,809.29
407 Info Technology	\$ 12,054.42	\$ 889.90	\$ 12,944.32
409 Facilities	\$ 17,923.96	\$ 1,334.17	\$ 19,258.13
410 Police	\$ 349,597.53	\$ 6,816.57	\$ 356,414.10
412 EMS Administration	\$ 9,672.66	\$ 715.04	\$ 10,387.70
413 Code Enforcement	\$ 22,482.72	\$ 1,671.67	\$ 24,154.39
416 Comm Development	\$ 2,294.84	\$ 169.41	\$ 2,464.25
427 Sanitation	\$ 75,107.93	\$ 5,592.42	\$ 80,700.35
429 Sewer Operations	\$ 19,406.85	\$ 1,450.25	\$ 20,857.10
430 PW Highways	\$ 115,614.38	\$ 8,633.53	\$ 124,247.91
450 Parks and Recreation	\$ 40,181.75	\$ 3,003.62	\$ 43,185.37
451 Ice Rink	\$ 15,309.30	\$ 1,143.59	\$ 16,452.89
454 Parks Maintenance	\$ 33,968.23	\$ 2,540.41	\$ 36,508.64
Totals	\$ 750,071.49	\$ 36,676.88	\$ 786,748.37
		Sewer Fund	\$ 20,857.10
		General Fund	\$ 765,891.27

Haverford Township
Credit Card Summary
(Formatted for ADA Accessibility)

Statement Ending Date: 1/27/2024
Payment Posting Date: 2/5/2024

Date	Vendor	Department	Description	GL Account	Amount
1/2/2024	PSU Cooperative Extens	Administration	Tree Tenders Training Series - A DeSanti	01-400-2602.02	\$ 40.00
1/2/2024	PSU Cooperative Extens	Administration	Arborist Short Course Series - A DeSanti	01-400-2602.02	\$ 250.00
1/2/2024	Isa	Administration	Arborists Certification Study Guide - A DeSanti	01-400-2602.02	\$ 133.22
1/3/2024	Psats	Administration	PSATS Training - M Buchanan	01-400-2602.02	\$ 45.00
1/8/2024	Omni Bedford Springs	Administration	Conference/Meeting lodging - D Burman	01-400-2602.02	\$ 224.06
1/8/2024	Nudys Café	Administration	Working meeting with new Chief Of Narberth Ambulance	01-400-2000.02	\$ 38.75
1/13/2024	EIG Constant Contact	Administration	Constant Contact Software	01-400-2000.02	\$ 137.75
12/28/2023	Amazon	IT	(2) USB charger, laptop power supply adapter cord	01-407-2002.02	\$ 77.98
12/28/2023	Philly Pretzel	Recreation	Rockin NYE pretzels	01-450-9220.02	\$ 90.00
12/28/2023	Amazon	Recreation	Rockin NYE décor	01-450-9220.02	\$ 23.64
12/28/2023	Amazon	Recreation	Rockin NYE candy	01-450-9220.02	\$ 52.41
12/28/2023	Amazon	Public Works	Pre-cut write on wipe off magnetic strips	01-430-2000.02	\$ 11.95
12/29/2023	National Construction	Recreation	Refund	01-454-4301.02	\$ (3.44)
12/30/2023	Bamboohr HRIS	HR	HRIS Monthly Subscription	01-406-2005.02	\$ 1,833.07
1/3/2024	Amazon	Police	(3) Streamlight battery	01-410-6109.02	\$ 61.23
1/3/2024	Amazon	Police	(2) Holster for iPhone 14 with belt clip	01-410-2000.02	\$ 35.70
1/3/2024	Amazon	Police	(5) Tactical magazine pouch, (5) tactical radio pouch	01-410-6000.02	\$ 158.75
1/4/2024	Amazon	Police	(2) Tactical drop leg gas mask hip platform	01-410-6000.02	\$ 71.90
1/4/2024	Amazon	Administration	1099 envelopes	01-400-2002.02	\$ 55.47
1/5/2024	Amazon	Recreation	Steering wheel cover for Ford F-150	01-454-4301.02	\$ 19.99
1/5/2024	Amazon	Recreation	Pipe cleaners	01-450-9220.02	\$ 7.99
1/5/2024	Amazon	Recreation	Pipe cleaners and elastic string for bracelets	01-450-9220.02	\$ 17.98
1/5/2024	Amazon	Recreation	Foot straps for rower	01-450-9220.02	\$ 18.99
1/5/2024	Amazon	Recreation	Watercolor refill bulk set of 50	01-450-9220.02	\$ 34.19
1/5/2024	Amazon	Recreation	Kids Night Out pizza	01-450-9220.02	\$ 350.00
1/6/2024	Amazon	Police	250 pack Poly coin bags, 72 pack 9V batteries	01-410-6113.02	\$ 344.99
1/6/2024	Amazon	Recreation	Construction paper, pencil erasers, pony beads and watercolor paper	01-450-9220.02	\$ 54.06
1/7/2024	Amazon	Recreation	100 cup Percolate coffee maker	01-450-9232.02	\$ 109.99
1/7/2024	Amazon	Administration	Label maker tape replacement	01-400-2002.02	\$ 10.49
1/8/2024	Peloton	Police	Gym Expense (recurring)	01-410-2000.02	\$ 46.64
1/9/2024	Amazon	Police	(2) 1,000 Wood coffee stirrers, (2) HP 64 ink cartridges	01-410-2002.02	\$ 109.76
1/9/2024	Ndal.Org	Recreation	Environmental training - P Gilbert	01-450-2602.02	\$ 238.50
1/10/2024	Amazon	Recreation	(5) Molle Double Pistol Mag pouch	01-410-6000.02	\$ 38.66
1/10/2024	Amazon	Public Works	Neoprene boots	01-430-2803.02	\$ 164.99
1/10/2024	Cummins Osm	Public Works	Cummins computer program	01-411-5107.02	\$ 770.00
1/10/2024	Amazon	Police	(2) Storage clipboard	01-410-6000.02	\$ 47.48
1/10/2024	Amazon	Police	Blackhawk duty belt	01-410-2803.02	\$ 62.16
1/10/2024	Amazon	Police	Blackhawk duty belt	01-410-2803.02	\$ 59.98
1/10/2024	The UPS Store	EAC/Admin	Shipping - TerraCycle	01-427-2772.02	\$ 13.72
1/10/2024	Amazon	Recreation	(2) Aluminum Citation Holder	01-410-6000.02	\$ 48.98

1/10/2024	Digicert	IT	3 year certificate	01-407-2005.02	\$ 1,346.80
1/11/2024	Amazon	Skatium	Commercial toilet seat	01-451-5117.02	\$ 51.38
1/11/2024	Quiver Farm Project	Recreation	Chick Hatching	01-450-9220.02	\$ 375.00
1/11/2024	BJS	Recreation	Little Explorers Snacks	01-450-9220.02	\$ 202.76
1/12/2024	Amazon	Recreation	Little Explorers Snacks	01-450-9220.02	\$ 69.16
1/13/2024	Intl Code Council Inc	Codes/ARPA	Inspector Training Program	01-130.00	\$ 83.74
1/15/2024	Amazon	Recreation	Volleyball clinic	01-450-9220.02	\$ 125.44
1/16/2024	Bagspot Pet Waste	Recreation	Dog waste bags	01-454-4301.02	\$ 398.65
1/16/2024	Adobe Acropro Subs	HR	Subscription	01-406-2000.02	\$ 21.19
1/17/2024	Amazon	Recreation	Little Explorers Snacks	01-450-9220.02	\$ 26.31
1/17/2024	AWS Inc	Police	40MM Bandoleer	01-410-6103.02	\$ 98.19
1/17/2024	Amazon	HR	PA Labor law poster	01-406-2000.02	\$ 176.70
1/17/2024	Plant Signs	EAC/Admin	Engraved plant id sign and stakes	01-427-2772.02	\$ 1,476.38
1/19/2024	Home Depot	Police	Black rolling toolbox with keyed lock	01-410-6141.02	\$ 328.91
1/19/2024	Amazon	Police	Windshield spray de-icer	01-410-2003.02	\$ 55.99
1/19/2024	Amazon	Police	Snow brush with detachable ice scraper	01-410-2003.02	\$ 122.84
1/19/2024	Amazon	Recreation	Measuring cup, aquarium cleaning brush and Folgers coffee	01-450-9232.02	\$ 75.35
1/21/2024	Userway.org	IT	Accessibility scanning and monitoring	01-407-2005.02	\$ 99.00
1/22/2024	Colonial Market	Fire	Awards dinner	01-411-2603.02	\$ 250.00
1/23/2024	Amazon	Police	Uniform belt	01-410-2803.02	\$ 74.00
1/23/2024	Onset Computer Corp	Recreation	Haverford Weather Station Annual HOBO Service Plan	01-450-2000.02	\$ 299.00
1/23/2024	Amazon	Police	Lenovo Laptop	01-450-2005.02	\$ 594.99
1/23/2024	Terminal Depot	Finance	Credit card machine paper rolls	01-402-2002.02	\$ 37.51
1/24/2024	Boccellas	Public Works	Breakfast for snow storm	01-430-2000.02	\$ 190.00
1/24/2024	Amazon	Recreation	Little Explorers Art Show	01-450-9220.02	\$ 94.29
1/24/2024	Terminal Depot	Finance	Refund for credit card machine paper rolls	01-402-2002.02	\$ (37.51)
1/24/2024	Pennsylvania State Assoc	Comm Dev	Training - M Buchanan	01-416-2602.02	\$ 25.00
1/25/2024	Intl Code Council Inc	Codes/ARPA	Inspector Apprentice Program	01-130.00	\$ 240.00
1/25/2024	Amazon	Recreation	Apple USB-C Headphone jack adapter	01-450-9220.02	\$ 25.44

Total Credit Card Purchasing as of January 27, 2024

\$ 12,833.49

Township of Haverford -Finance Department

Memorandum

Date: February 05, 2024

To: David R. Burman, Township Manager

From: Aimee Cuthbertson, Director of Finance/Asst Township Manager

Re: Re-Appointment of Jennifer W. Brown, Esquire as Act 511 Special Counsel

For many years, the Township has utilized the professional services of Jennifer W. Brown, Esquire as special counsel for any matters related to the enforcement and administration of the Township's Act 511 taxes with primary emphasis on the business privilege, mercantile and local services tax.

As an expert in this specialty tax field unique to municipal entities, I am recommending Ms. Brown's reappointment as special counsel for Act 511 matters at a rate of \$250 per hour. The services of special counsel are on an "as needed" basis.

The recommendation has also been reviewed by John Walko in his role as Township Solicitor.

If you have any questions, please do not hesitate to contact me.

Township of Haverford - Ordinance Number P1-2024

An Ordinance of the Township of Haverford, County of Delaware, Commonwealth of Pennsylvania, amending and supplementing the General Laws of the Township of Haverford Chapter 95, Article III Recycling, Sections 95-23 and 95-25 by adding a definition of Community Event and requiring organizers to provide separate containers for and to collect recyclable materials.

Section 1. - § 95-23 Definitions.

Add: Community Event.

Any gathering that is open to the public including, without limitation, any parade, outdoor demonstration, meeting, dance, live entertainment, concert, rock group, stage show, burlesque, vaudeville, disc jockey or talent show, for any and all purposes.

Section 2. - § 95-25 Recyclables.

Add: G. Community Events.

(1) The organizers or sponsors of a community event shall establish a collection system that includes an appropriate number of recycling containers at easily accessible locations to accommodate the amount of recyclable materials generated. Community activity organizers and sponsors shall provide signage and/or labels on recycling containers to indicate what recyclable materials are to be source separated by event participants.

(2) Organizers or sponsors shall contact the township for the collection of recyclable materials, at a fee to be determined by the Township.

Section 3. Any ordinance or part of ordinance to the extent that it is inconsistent herewith is hereby repealed.

Section 4. Severability. The provision of this ordinance are severable and if any section, sentence, clause, part, or provision hereof shall be held illegal, invalid or unconstitutional by any court of competent jurisdiction, such decision of this shall not affect or impair the remaining sections, sentences, clauses, parts or provisions of this ordinance. It is hereby declared to be the Intent of the board that this ordinance would have been adopted if such illegal, invalid or unconstitutional section, sentence, clause, part or provision had not been included herein.

Section 5. Effective date. This ordinance shall become effective 10 days following final adoption by the board of commissioners and publication as required by law.

Adopted this 12th day of February, 2024.

Township of Haverford
By: C. Lawrence Holmes, Esq.
President Board of commissioners

Attested by: David R. Burman
Township Manager/Secretary

Township of Haverford - Ordinance Number P2-2024

An ordinance of the township of Haverford, County of Delaware, commonwealth of Pennsylvania, further amending and supplementing Ordinance No. 1960, adopted June 30, 1986, and known as "general laws of the Township of Haverford" chapter 175, vehicles and traffic.

Be it enacted and ordained by the Board of Commissioners of the Township of Haverford, County of Delaware, Commonwealth of Pennsylvania, and it is hereby enacted and ordained by the authority of the same:

Section 1. Section 175-94, Schedule XIX: Parking Time Limited

Establish:

On the west side of Allston Road from Brookline Boulevard to, but not including 1204 Allston Road, 15-minute parking from 8:00 a.m. to 4:00 p.m., Monday through Friday

Section 2. That Section 175-91, Schedule XVI: Parking of All Vehicles Prohibited at All Times

Rescind:

East side of Allston Road from Brookline Boulevard to Sagamore

West side of Allston Road from Brookline Boulevard to a point 35 feet south thereof

Section 3. That Section 175-95, Schedule XX: Special Purpose Parking Zones:

Rescind:

On the West side of Allston Road, approximately 75 feet south of its intersection with Brookline Boulevard

Section 4. Upon effective date of this ordinance, the Highway Department shall install appropriate signs in the designated section or zones giving notice of the regulations aforesaid.

Section 5. Any ordinance or part of an ordinance to the extent that it is inconsistent herewith is hereby repealed.

Adopted this 12th day of February, 2024.

Township of Haverford

By: C. Lawrence Holmes, Esq.
President

Attest: David R. Burman
Township Manager/Secretary

Township of Haverford - Ordinance Number P3-2024

An Ordinance of the Township of Haverford, County of Delaware, Commonwealth of Pennsylvania, further amending and supplementing Ordinance 1960, adopted June 30, 1980, and known as the "General Laws of the Township of Haverford" authorizing the lease of certain township grounds.

Now, therefore, it is hereby ordained and enacted that:

Section I: Pursuant to Section 707, paragraph A, of the Home Rule Charter, the Township hereby authorizes a renewal lease agreement with Shef & Sons, LLC dba Hav-A-Burger, Essington, PA for a portion of certain property located at 1018 Darby Road (the Skatium), Havertown, PA subject to review by the Township Solicitor and further subject to the approval of the Township Manager of the final document.

Section II: All Township elected and appointed officials are authorized to take all action necessary to ensure the implementation and effect the purpose hereof.

Section III: Any and all Ordinances and/or Resolutions, or parts thereof, conflicting herewith are repealed insofar as the matters herein are affected.

Section IV: This is effective ten (10) days following final adoption by the Board of Commissioners and publication as required by law, and shall remain in effect hereafter until revised, amended, or revoked by action of the Board of Commissioners of the Township of Haverford.

Adopted by the Township Board of Commissioners this (day) day of (month) , 2024.

Township of Haverford

By:

C. Lawrence Holmes, Esq.
President, Board of Commissioners

Attest:

David R. Burman,
Township Manager/Secretary

Township of Haverford - Finance Department

Memorandum

Date: February 05, 2024

To: David R. Burman, Township Manager

From: Aimee Cuthbertson, Director of Finance/Asst Township Manager

Re: Renewal of Skatium Café Lease

Staff has been in lease renewal discussions with the current tenant as the existing lease expired January 31, 2024. A two-year renewal term is proposed.

The current rent is \$1,300 per month with \$50 per party hosted in the upstairs party room. Renewal terms, which have been agreed to in principle, will be an increase to \$1,360 in year 1 of the renewal and to \$1,425 in year 2. The \$50 party fee will remain unchanged.

We added language including a required cleaning of the exhaust hood system every six (6) months, at the expense of the tenant. Additionally, the Township committed to the installation of a concrete pad for trash storage on the café entrance side behind the existing fenced trash area. This is planned for the Spring of 2024 and will be completed by Township staff.

If you have any questions, please do not hesitate to contact me.

Township of Haverford - Ordinance Number P4-2024

An Ordinance of the Township of Haverford, County of Delaware, Commonwealth of Pennsylvania, further amending and supplementing ordinance no. 1960, adopted June 30, 1986, and known as "General Laws of the Township of Haverford" Chapter 175, Vehicles and Traffic.

Be it enacted and ordained by the Board of Commissioners of the Township of Haverford, County of Delaware, Commonwealth of Pennsylvania, and it is hereby enacted and ordained by the authority of the same:

Section 1. That Section 175-96, Article XX, Special Purpose Parking Zones:
Establish in front of 2447 Wynnefield Drive

Section 2. That Section 175-91 Schedule XVI: Parking of All Vehicles Prohibited at All Times:
No Parking Here to Corner
the unit block of Colfax Road, north side, from the corner of Darby Road to a point 60 feet west.

Section 3. That Section 175-99, Schedule XXIV, Sticker Parking Only
Rescind Permit Parking Only on Mifflin Avenue

Section 4. Upon effective date of this ordinance, the Highway Department shall install appropriate signs in the designated section or zones giving notice of the regulations aforesaid.

Section 5. Any ordinance or part of an ordinance to the extent that it is inconsistent herewith is hereby repealed.

Adopted this day of , 2024.

Township of Haverford

C. Lawrence Holmes, Esq.
President

Attest: David R. Burman
Township Manager/Secretary

Township of Haverford - Ordinance Number P4-2024

An Ordinance of the Township of Haverford, County of Delaware, Commonwealth of Pennsylvania, further amending and supplementing ordinance no. 1960, adopted June 30, 1986, and known as "General Laws of the Township of Haverford" Chapter 175, Vehicles and Traffic.

Be it enacted and ordained by the Board of Commissioners of the Township of Haverford, County of Delaware, Commonwealth of Pennsylvania, and it is hereby enacted and ordained by the authority of the same:

Section 1. That Section 175-96, Article XX, Special Purpose Parking Zones:
Establish in front of 2447 Wynnefield Drive

Section 2. That Section 175-91 Schedule XVI: Parking of All Vehicles Prohibited at All Times:
No Parking Here to Corner
the unit block of Colfax Road, north side, from the corner of Darby Road to a point 60 feet west.

Section 3. That Section 175-99, Schedule XXIV, Sticker Parking Only
Rescind Permit Parking Only on Mifflin Avenue

Section 4. Upon effective date of this ordinance, the Highway Department shall install appropriate signs in the designated section or zones giving notice of the regulations aforesaid.

Section 5. Any ordinance or part of an ordinance to the extent that it is inconsistent herewith is hereby repealed.

Adopted this day of , 2024.

Township of Haverford

C. Lawrence Holmes, Esq.
President

Attest: David R. Burman
Township Manager/Secretary

Resolution No. 2360-2024

Whereas, the Preliminary / Final Subdivision / Land Development Plan for Carmanico Homes, LLC, 14 Claremont Blvd., Haverford, PA, Delaware County, known as D.C. Folio Nos. 22-00-00355-00 has been submitted to subdivide an existing 30,625 square foot lot into three building lots resulting in the following area: Lot 1 to contain 10,210 square feet, Lot 2 to contain 10,208 square feet and Lot 3 to contain 10, 208 square feet. Each lot is proposed with a single-family dwelling of 1,785 square feet with individual on-site stormwater facilities.

The properties are zoned R-5 Low-to-Medium Density Residential District, and are located in the 1st Ward. The aforesaid plans were prepared by G.D Houtman & Son, Inc., Media, PA, dated November 30, 2023; and

Whereas, the Planning Commission of Haverford Township at the public meeting of Thursday, January 11, 2024, did vote to recommend approval of the plans subject to the comments contained within the January 4, 2024 review letter prepared by Pennoni Associates and that the open space requirement be addressed to the Board of Commissioners satisfaction; and

Whereas, said plans have been submitted before the Board of Commissioners of the Township of Haverford for consideration in accordance with the Pennsylvania Municipalities Planning Code, Act 247, as amended, and pursuant to the Haverford Township Subdivision and Land Development Regulations, Ordinance 1960, Chapter 160, Sections 4. A and B,

Now, therefore, be it Resolved, by the Board of Commissioners of the Township of Haverford, County of Delaware, Commonwealth of Pennsylvania, that the recommendations and findings of the Planning Commission are hereby adopted and the Preliminary / Final / Land Development Plan for Carmanico Homes, LLC, 14 Claremont Blvd., Haverford Township, Delaware County, dated November 30, 2023, is approved subject to compliance with the recommendations described hereinabove.

Resolved this 12th day of February, 2024.

Township of Haverford

By: C. Lawrence Holmes, Esq. President
President, Board of Commissioners

Attest: David R. Burman,
Township Manager/Secretary

The Applicant hereby acknowledges that any revision to the approved SWM site plan must be approved by the Municipality, and that a revised erosion and sediment control plan must be submitted to the Conservation District for a determination of adequacy.

Present Owner _____
Date _____

CORPORATE ACKNOWLEDGMENT FOR PLAN

COMMONWEALTH OF PENNSYLVANIA :
COUNTY OF DELAWARE :

On this _____ day of _____, 2023, before me the undersigned, personally appeared Daniel Caramanico, who being duly sworn according to law, acknowledged himself/herself to be President of Caramanico Homes, LLC and that he, as such officer duly authorized to do so, deposes and says that Caramanico Homes, LLC is the owner/Equitable Owner of the property shown on this Plan, that this Plan was made at the direction of the Corporation and the Corporation acknowledges the same to be its act and Plan and desires the same to be recorded as such according to law.

Witness my hand and seal the day above written.

Corporate Name: Caramanico Homes, LLC
By: Daniel Caramanico
Title: President
Notary Public: _____
My Commission Expires: _____

State of Pennsylvania, County of Delaware

On this _____ day of _____, 2023, before me, the undersigned officer, personally appeared _____, who being duly sworn according to law, deposed and says that he is the owner (or equitable owner) of the property shown on this plan, that the subdivision plan therof was made at his direction and that he acknowledges the same to be his act and plan and desires the same to be recorded as such according to law.
Witness my hand and seal the day and date above written.

(signature of individual)
(Notary public or other officer)
(My commission expires)

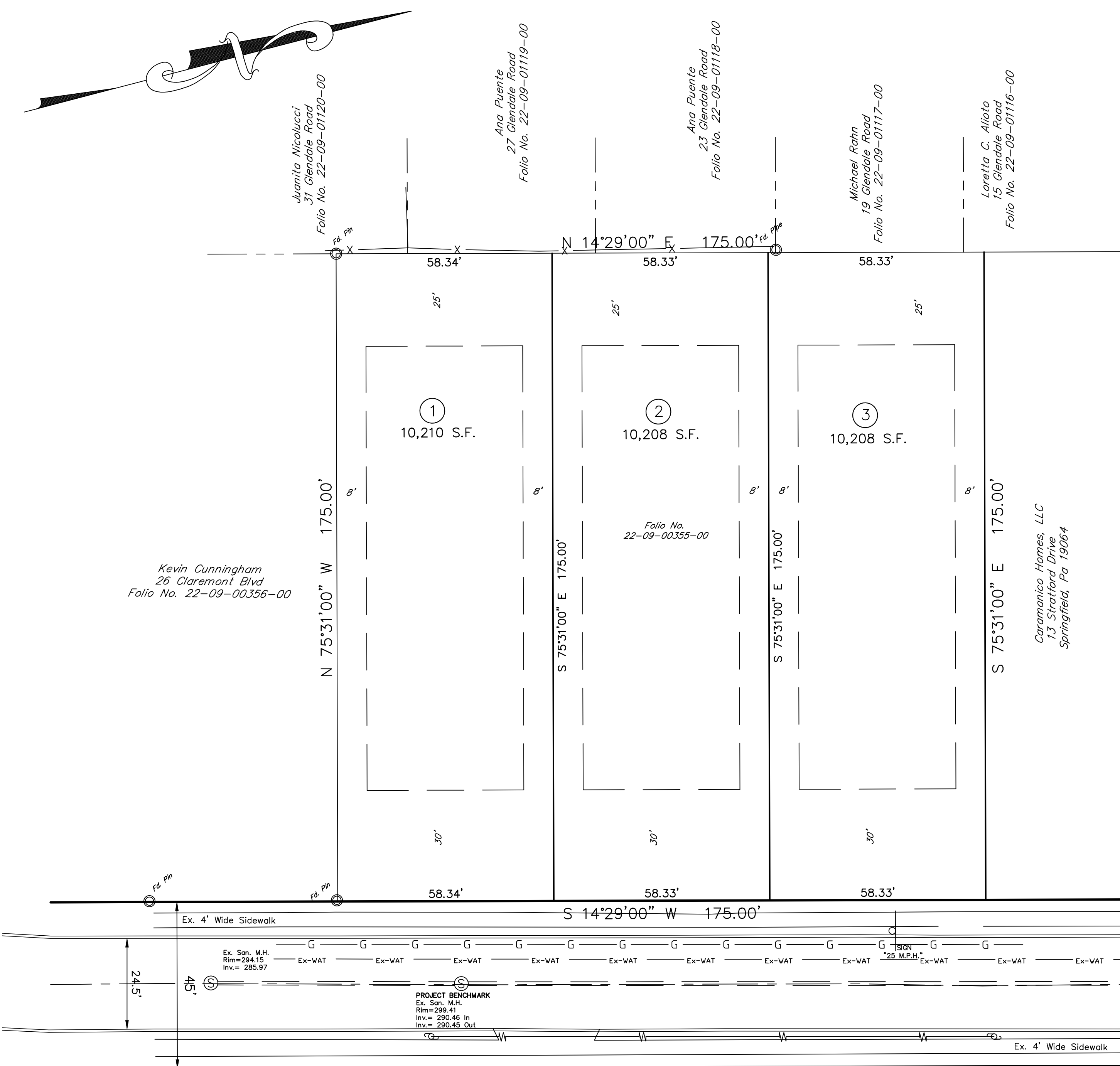

POST CONSTRUCTION STORMWATER MANAGEMENT NOTES:

- Post development stormwater management facilities at the property consist of the following:
 - Underground stormwater infiltration Bed.
 - Maintenance responsibilities for all the Stormwater facilities on the site, including the underground Stormwater Detention/Retention Basins and Underground Infiltration Bed, shall be that of the individual lot owner(s) on which the BMP's are located.
 - Maintenance program:
 - Infiltration beds:**
Infiltration beds shall be inspected on a Quarterly Basis

Debris Trap:

A sump area has been provided within each inlet servicing the proposed seepage bed. The sump area of the inlet is the area between the bottom of the lowermost pipe in the inlet and the bottom of the Inlet Box. Inspect debris trap at the noted frequencies. Remove debris and sediment from the sump areas when it has reached a depth of eight (8) inches. Dispose sediment and debris in accordance with local ordinances.

Stone Infiltration Area:

Inspect stone infiltration area at the noted frequencies. Ensure that ponded water at infiltration bed is percolating properly. Monitor water level in seepage bed area by inspecting water level in debris traps. Water at infiltration bed location as viewed from debris trap should not stay ponded for more than 3 days. Stone and sediment shall be removed from clogged beds and replaced as necessary. Install new filter fabric at repaired areas.

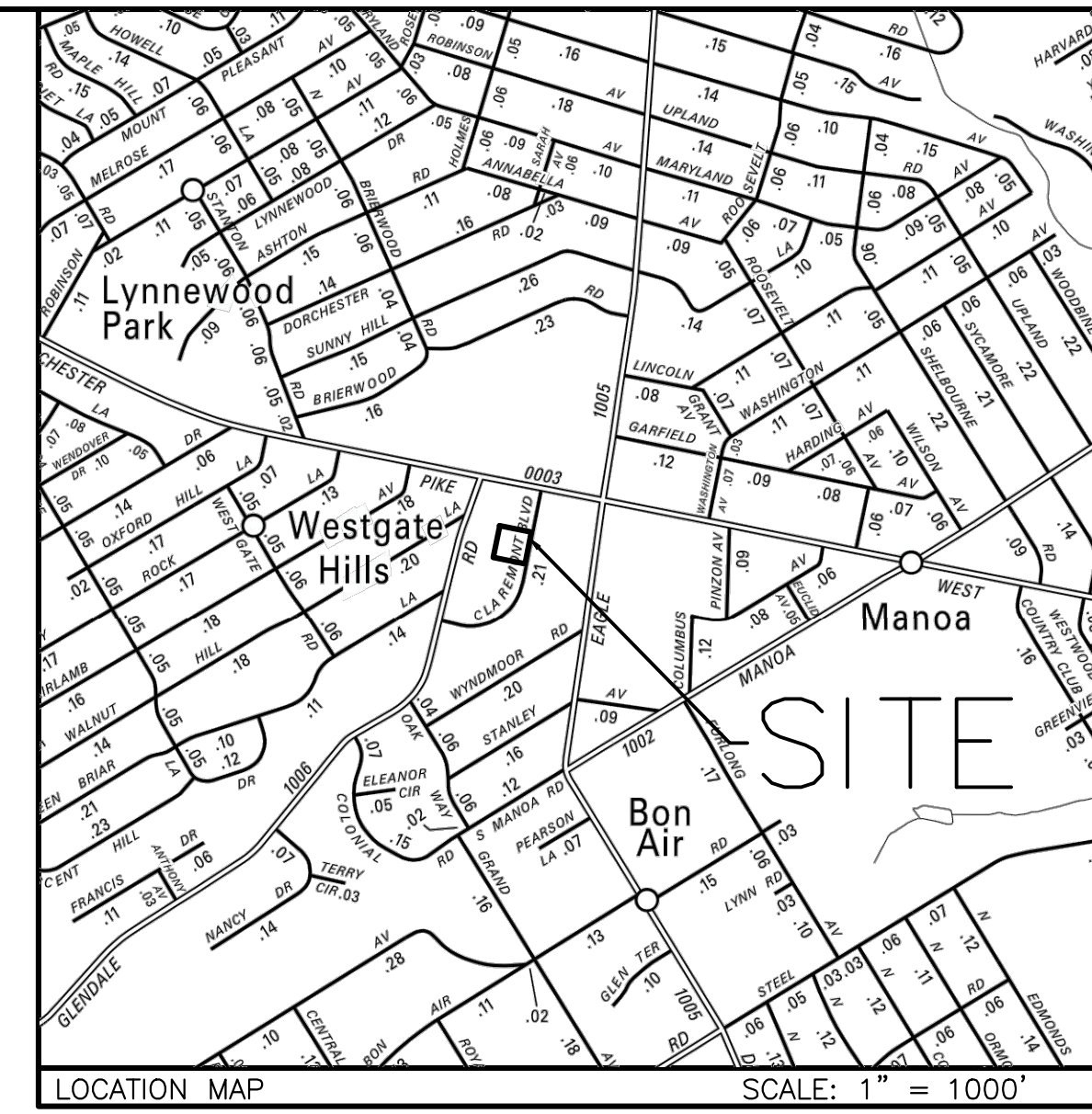

GENERAL NOTES:

Purpose: Applicant is proposing the subdivision of parcel 22-00-00355-00 into 3 Lots. The created lots will be developed with single family custom homes.

- Lot Area 30,625 S.F. (0.703 Acres)
- Zoned R-5

Minimum Lot Size	Required	Proposed
Minimum Lot Size	5,500 Sq.Ft.	10,208 s.f. Min
Minimum Lot Width at street	38'	58.33'
Minimum Lot Width at building	50'	58.33'
Minimum Front Yard	30'	31'
Minimum Side Yard	8'	8.42'
Minimum Side Yard Aggr.	16'	16.84'
Minimum Rear Yard	25'	101'
Maximum Building Coverage	30%	17.5% (1,785 s.f.)
Maximum Impervious Coverage	45%	23.0% (2,350 s.f.)
Maximum Height	35' or 3.5 Stories	< 35' or 3.5 Stories
- Site contains no Steep or Very Steep Slopes.
- Lots serviced by public water service and sewage disposal.
- Contours from field survey performed using Global Positioning System (GPS) Equipment. Elevation Per North American Vertical Datum of 1985. Project Benchmark – Rim of sanitary manhole located in Claremont Boulevard. Rim = 299.41
- Soils information from Soil Survey– Chester and Delaware Counties, Pennsylvania, Series 1959, No. 19, Issued May 1963. The Soil Types are as follows:
Me – Made land schist & gneiss materials
Mc – Made land silt & clay materials
- Owner/Applicant: Caramanico Homes, LLC
13 Stratford Drive
Springfield, PA 19064
- There is no 100-Year Flood Plain on this site as shown on the Flood Insurance rate Map (FIRM), Delaware County, Pa, Panel 102 of 250, Map Number 42045C0102F – Map revised November 18, 2009
- Reference Plan: Plan of Lots of "Claremont Hills", dated April 7th, 1925 prepared by Franklin & Company.
- This plan represents lots 199 through 204, Block I as shown on the reference plan.
- Addresses for the proposed lots are to be provided by the Township and or local post office.
- All standard curb and sidewalk along the property frontages shall be replaced at the discretion of the Township Engineer.
- Work is scheduled to begin June '24 and completed in June '25.

WAIVER REQUEST:

160-3E – The applicant is requesting a waiver from Preliminary Plan submittal and to submit plans as Final.

CLAREMONT BOULEVARD

DESIGN ENGINEERS CERTIFICATIONS:

- I hereby certify that the Stormwater Management Site Plan meets all design standards and criteria of the Haverford Township Stormwater Management Ordinance.
- The proposed grading activities shall not significantly increase stormwater runoff to, and/or otherwise adversely impact, downstream properties except as may be part of an approved Stormwater Management Plan (as defined by Haverford Township Code)
- The accuracy of this plan and details are in accordance with Act 367, known as the Professional Engineers Registration Law (P.L. 913, No. 367.63 P.S. 151), as amended.

I, Gustave N. Houtmann, P.E., on this date hereby certify, to the best of my knowledge and belief, that the aforementioned statements and certifications are true and accurate.

(Signature & Seal)

Date

The information shown on this plan is the result of a professional service rendered by G.D. Houtman & Son, Inc. Reproduction of this plan without approval of G.D. Houtman & Son, Inc. is not permitted. The reproduction of a copy of this plan for the purpose of creating additional copies or making a copy of this plan shall, in no circumstance, be approved. Certification for the work contained herein is limited to the entity for whom the work was performed as of the date shown on the plans.
Note: All locations of existing utilities shown on the plan have been developed from existing utility records and / or above ground examination of the site. Completeness or accuracy of locations and depth of underground utilities or structures cannot be guaranteed. Contractor must verify location and depth of all underground utilities and facilities before start of work, as per PA Act 181 as per the latest amendment of PA Act 287 of 1974, Effective Mar. 28, 2007.

GRAPHIC SCALE

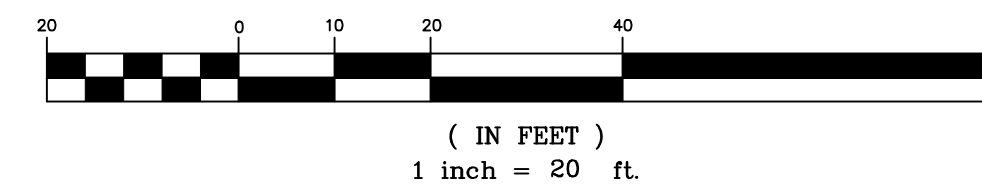

G. D. Houtman & Son, Inc. reserves its common law copyright and all other proprietary rights in these plans. All drawings, specifications and copies thereof are to remain property of G. D. Houtman & Son, Inc. They are to be used only in respect to this project. They are not intended or represented to be suitable for reuse by owner or others on extensions of project or any other project. They are not to be assigned to any third party without first obtaining written permission by G.D. Houtman & Son, Inc. Any re-use without written permission for the specific purpose intended will be at the third party's sole risk and without liability or legal exposure to G. D. Houtman & Son, Inc. The third party shall further indemnify and hold harmless G. D. Houtman & Son, Inc. from all claims, damages, losses and expenses arising thereto or resulting therefrom.

These plans were prepared to obtain Subdivision/Land Development approval from the governing Municipality and to obtain certain permits from state and federal agencies. If a surveyor or engineer other than G. D. Houtman & Son, Inc. is contacted to perform construction stake-out services, said surveyor or engineer shall assume the responsibility for verifying dimensions, elevations, presence of underground utilities, utility interference, building size, etc. for coordinating information shown on lay-out plans, grading plans, utility plans, profiles, and details and for coordinating these plans with plans prepared by others such as utility companies, architectural building plans, landscape plans, lighting plans and etc.

DATE	REVISION

SCALE 1" = 20'
DATE November 30, 2023

RECORD PLAN OF PROPERTY FOR
CARAMANICO HOMES, LLC
HAVERFORD TOWNSHIP
DELAWARE COUNTY, PA

G.D. HOUTMAN & SON, INC.	Sheet 1 of 6
CIVIL ENGINEERS—LAND SURVEYORS	PROJECT Caramanico
LAND PLANNERS	WORK SHEET 39258
139 EAST BALTIMORE PIKE MEDIA, PA 19063 (610)585-4383	FILE 39258

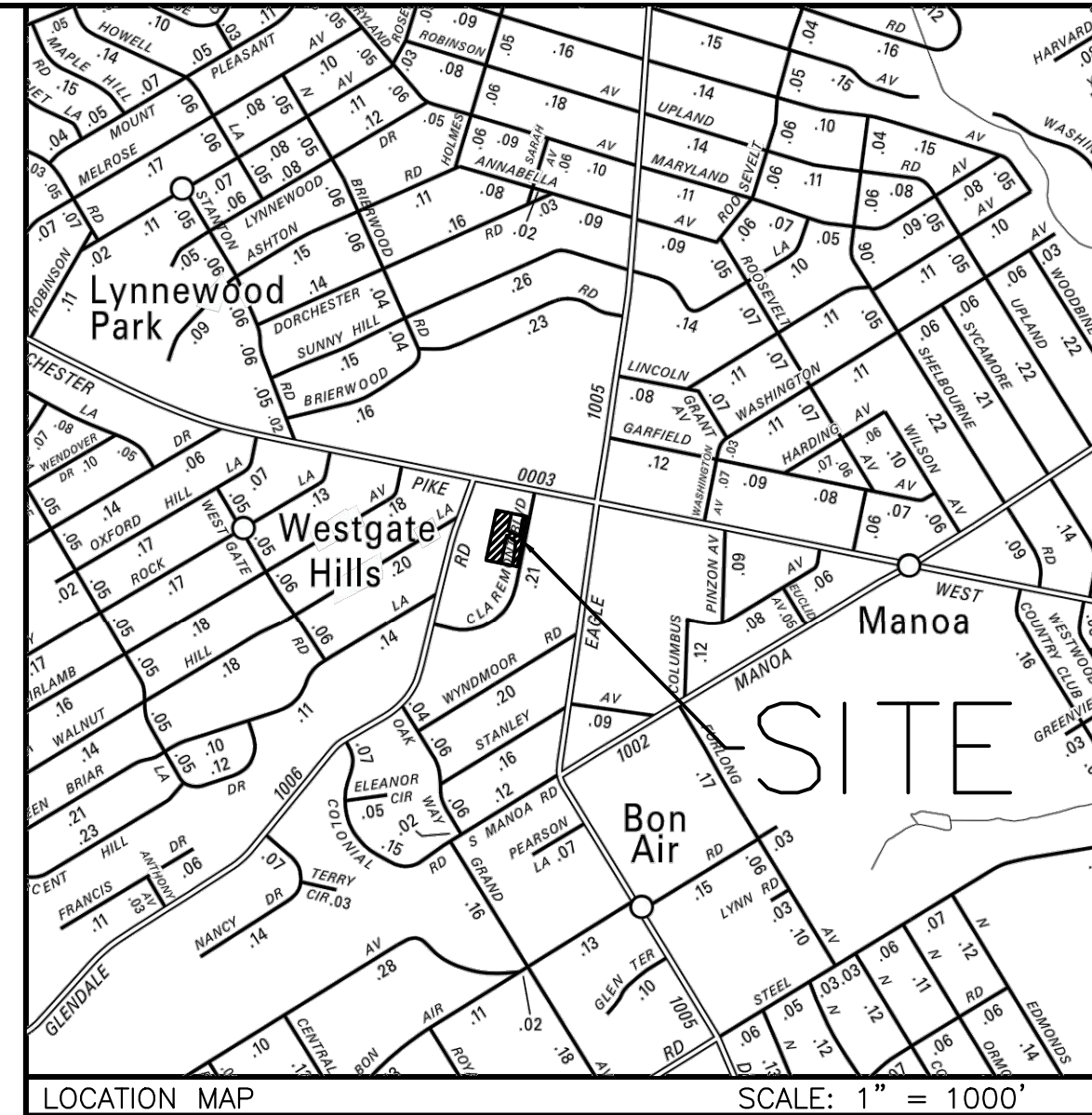
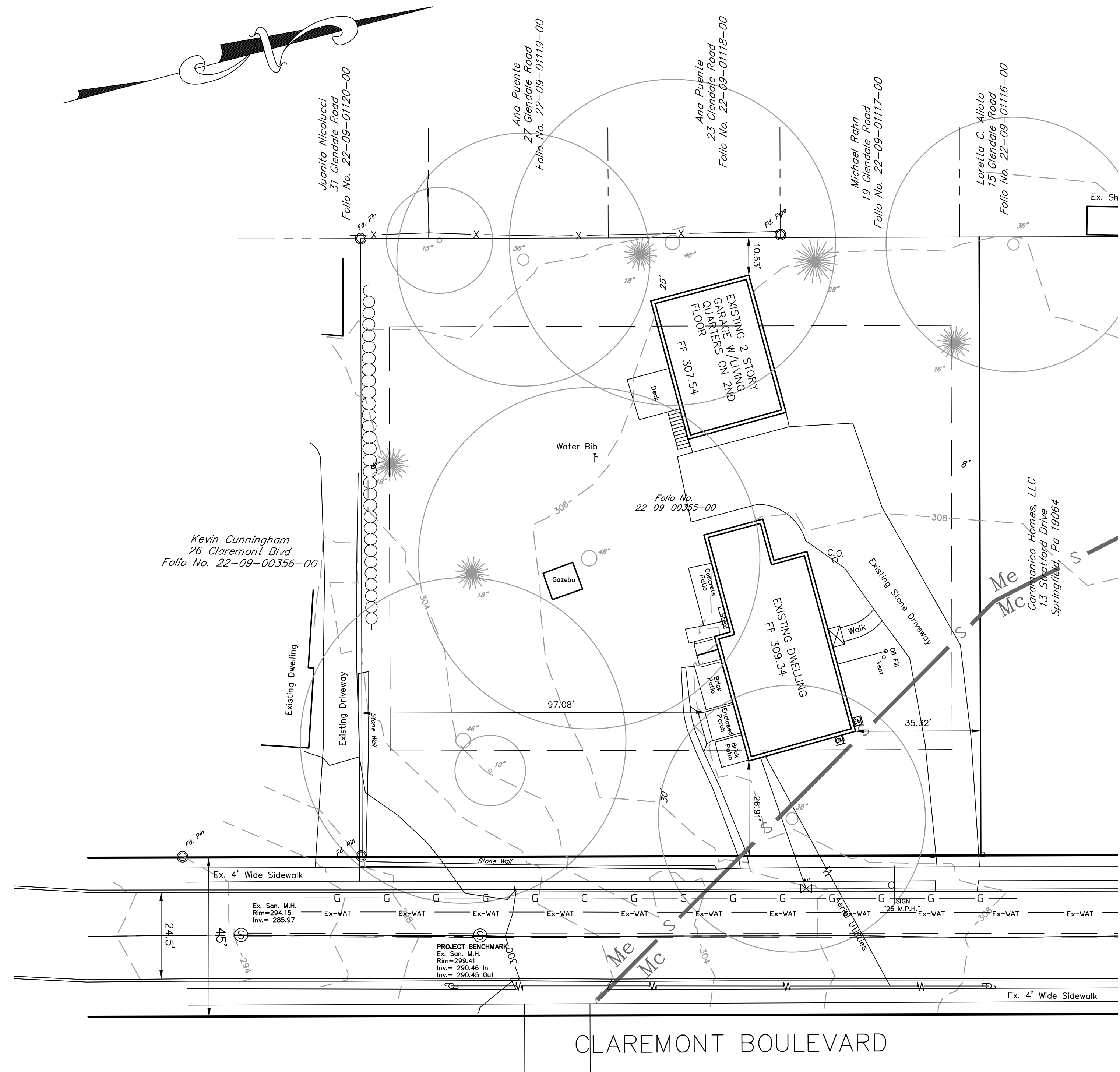

- GENERAL NOTES:
- Lot Area 30,625 S.F. (0.703 Acres)
 - Zoned R-5
 - Minimum Lot Size - 5,500 Sq.Ft.
 - Minimum Lot Width - 38' at street, 50' at building
 - Minimum Front Yard - 30'
 - Minimum Side Yard - 8'
 - Minimum Side Yard Aggr. - 16'
 - Minimum Rear Yard - 25'
 - Maximum Building Coverage - 30%
 - Maximum Impervious Coverage - 45%
 - Maximum Height - 35' or 3.5 Stories
 - Site contains no Steep or Very Steep Slopes.
 - Lots serviced by public water & public sewage.
 - Contours from field survey performed using Global Positioning System (GPS) Equipment. Elevation Per North American Vertical Datum of 1988. Project Benchmark - Rim of sanitary manhole located in Claremont Boulevard. Rim = 299.41
 - Soils information from Soil Survey- Chester and Delaware Counties, Pennsylvania, Series 1959, No. 19, Issued May 1963. The Soil Types are as follows:
 - Me - Made land schist & gneiss materials
 - Mc - Made land silt & clay materials
 - Owner/Applicant: Caramanico Homes, LLC
13 Stratford Drive
Springfield, PA 19064
 - There is no 100-Year Flood Plain on this site as shown on the Flood Insurance rate Map (FIRM), Delaware County, Pa, Panel 102 of 250, Map Number 42045C0102F - Map revised November 18, 2009

CLAREMONT BOULEVARD

LEGEND

- EXISTING UTILITY POLE
- EXISTING WATER VALVE
- EXISTING DECIDUOUS TREE
- EXISTING EVERGREEN TREE
- DENOTES EXISTING TREE TO BE REMOVED
- EXISTING 2' CONTOUR
- EXISTING 10' CONTOUR
- EXISTING INLET
- EXISTING SANITARY MANHOLE
- EXISTING SANITARY SEWER
- EXISTING WATER MAIN
- EX-VAT EXISTING WATER SERVICE
- G EXISTING GAS LINE
- X-X EXISTING FENCES

#1 ▲ PERCOLATION TEST LOCATION

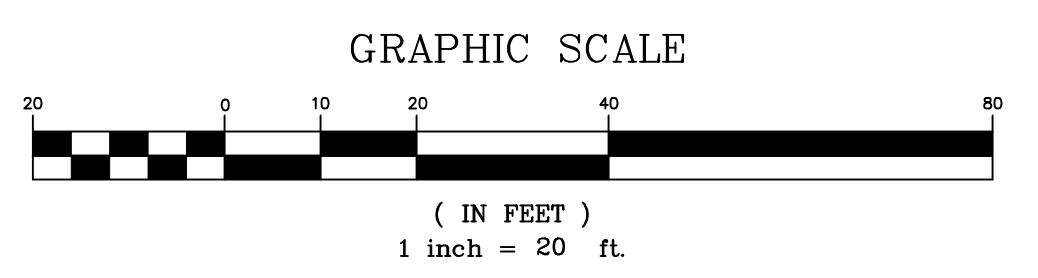

The information shown on this plan is the result of a professional service rendered by G.D. Houtman & Son, Inc. Reproduction of this plan without approval of G.D. Houtman & Son, Inc. is not permitted. The reproduction of a copy of this plan for the purpose of creating additional copies or making a plan shall, in no circumstance, be approved. Certification for the work contained herein is limited to the entity for whom the work was performed as of the date shown on the plans.

Note: All locations of existing utilities shown on the plan have been developed from existing utility records and / or above ground examination of the site. Completeness or accuracy of locations and depth of underground utilities or structures cannot be guaranteed. Contractor must verify location and depth of all underground utilities and facilities before start of work, as per PA Act 181 as per the latest amendment of PA Act 287 of 1974, Effective Mar. 28, 2007.

G. D. Houtman & Son, Inc. reserves its common law copyright and all other proprietary rights in these plans. All drawings, specifications and copies thereof are to remain property of G. D. Houtman & Son, Inc. They are to be used only in respect to this project. They are not to be assigned or represented to be suitable for reuse by owner or others on extensions of project or any other project. They are not to be assigned to any third party without first obtaining written permission by G.D. Houtman & Son, Inc. Any re-use without written permission for the specific purpose intended will be at the third party's sole risk and without liability or legal exposure to G. D. Houtman & Son, Inc. The third party shall further indemnify and hold harmless G. D. Houtman & Son, Inc. from all claims, damages, losses and expenses arising thereto or resulting therefrom.

These plans were prepared to obtain Subdivision/Land Development approval from the governing Municipality and to obtain certain permits from state and federal agencies. If a surveyor or engineer other than G. D. Houtman & Son, Inc. is contacted to perform construction stake-out services, sold surveyor or engineer shall assume the responsibility for verifying dimensions, elevations, presence of underground utilities, utility interference, building size, etc. for coordinating information shown on lay-out plans, grading plans, utility plans, profiles, and details and for coordinating these plans with plans prepared by others such as utility companies, architectural building plans, landscape plans, lighting plans and etc.

DATE	REVISION	SCALE 1" = 20' DATE November 30, 2023	EXISTING CONDITIONS PLAN OF PROPERTY FOR CARAMANICO HOMES, LLC HAVERFORD TOWNSHIP DELAWARE COUNTY, PA	G.D. HOUTMAN & SON, INC. CIVIL ENGINEERS-LAND SURVEYORS LAND PLANNERS 139 EAST BALTIMORE PIKE MEDIA, PA 19063 (610)565-6363	Sheet 2 of 6
					PROJECT Caramanico WORK SHEET FILE 39258 39258

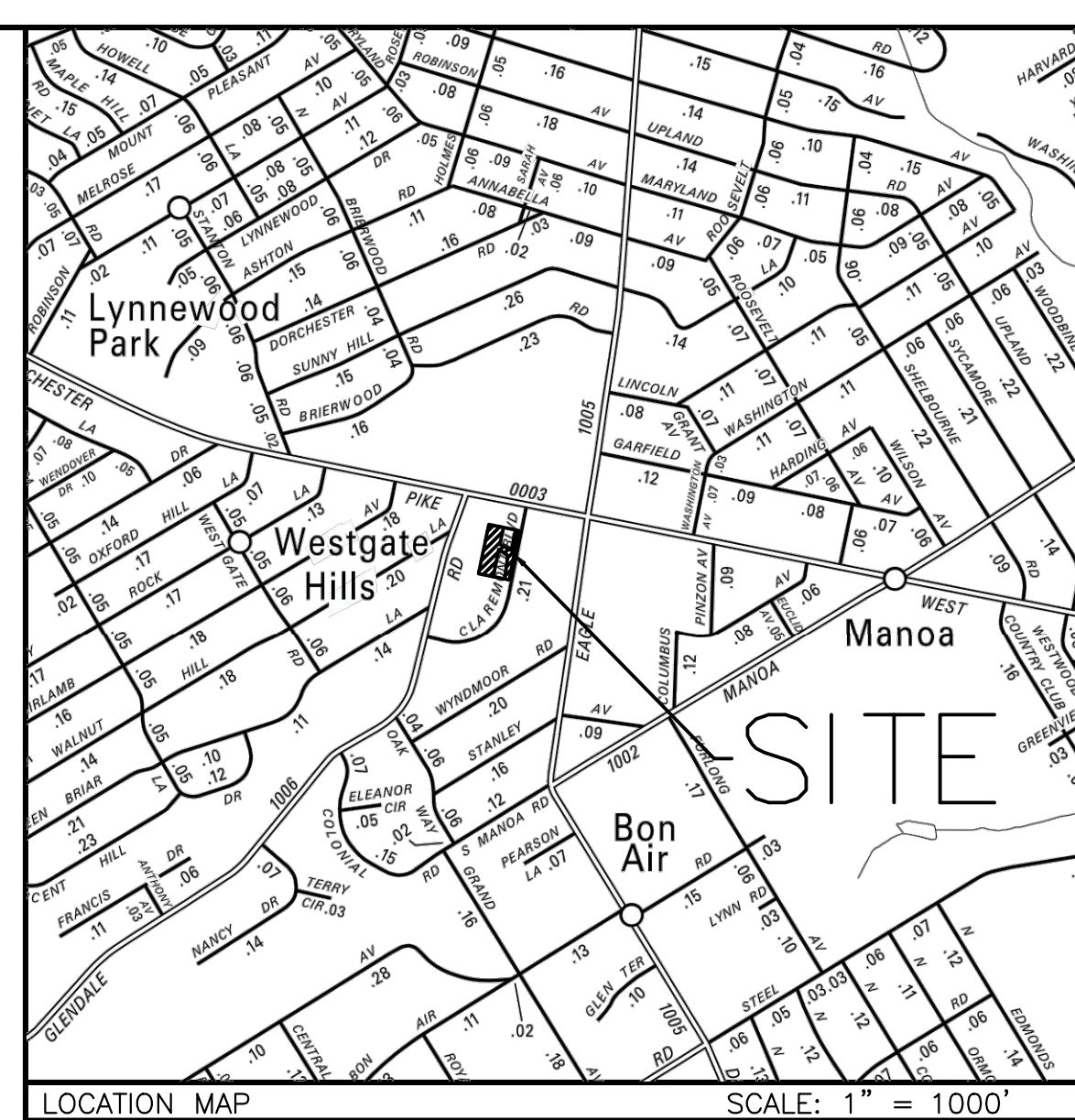
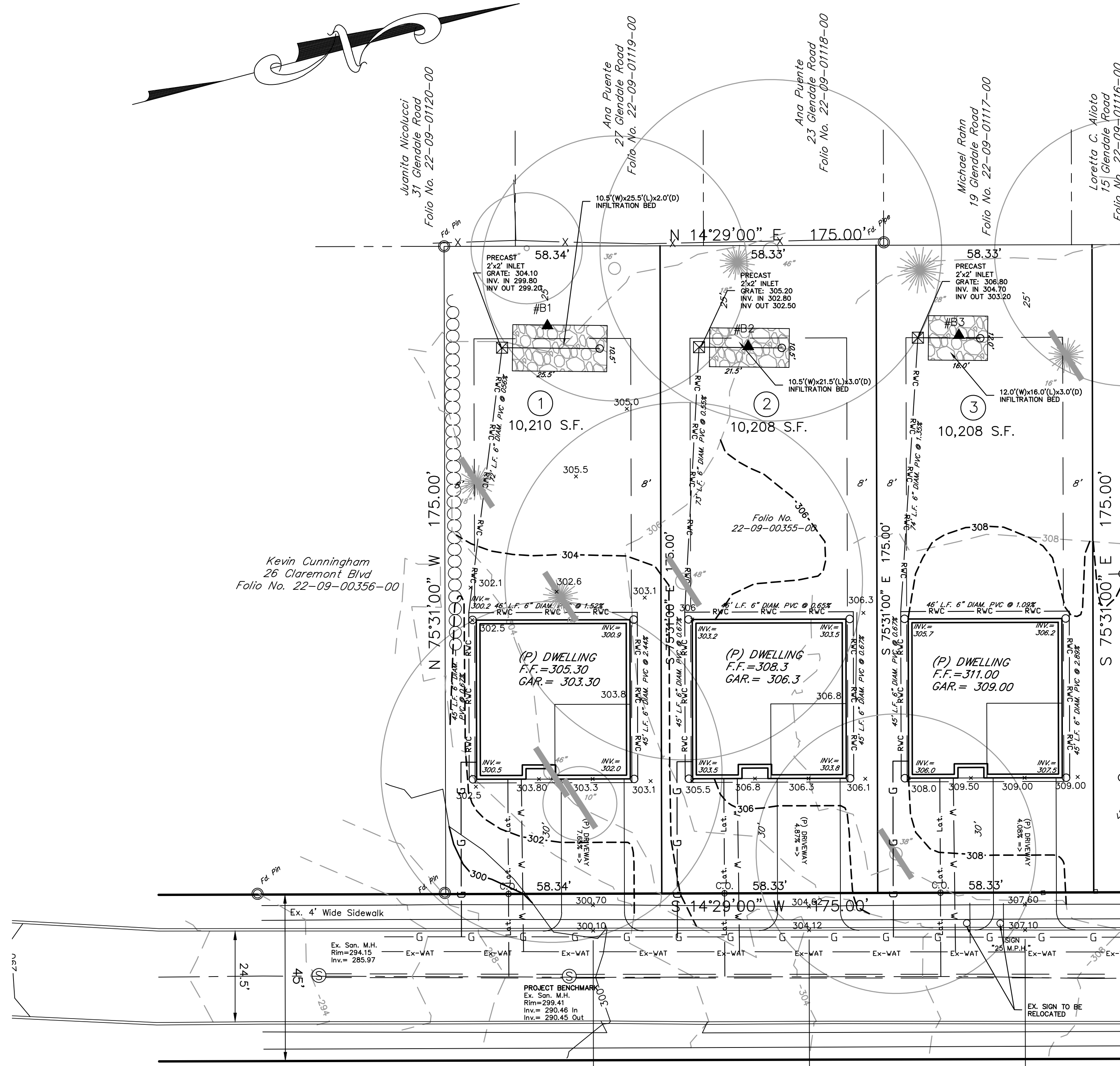

Kevin Cunningham
26 Claremont Blvd
Folio No. 22-09-00356-00

Juanita Nicoletti
31 Glendale Road
Folio No. 22-09-01120-00

Ana Puente
27 Glendale Road
Folio No. 22-09-01119-00

Ana Puente
23 Glendale Road
Folio No. 22-09-01118-00

Michael Rahn
19 Glendale Road
Folio No. 22-09-01117-00

Loretta C. Alitto
15 Glendale Road
Folio No. 22-09-01116-00

CLAREMONT BOULEVARD

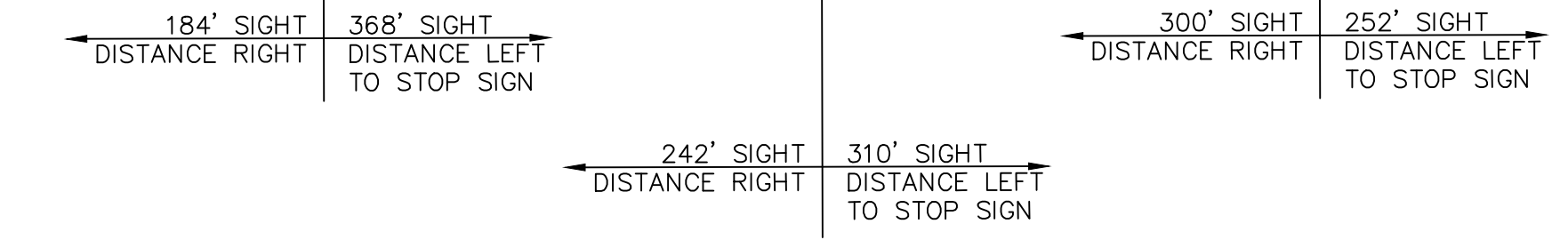

VEGETATION LOCATED WITHIN THE RIGHT-OF-WAY OF CLAREMONT BLVD. IS TO BE TRIMMED AS NECESSARY TO PROVIDE LISTED SIGHT DISTANCES

- LEGEND**
- EXISTING UTILITY POLE
 - EXISTING WATER VALVE
 - EXISTING DECIDUOUS TREE
 - EXISTING EVERGREEN TREE
 - DENOTES EXISTING TREE TO BE REMOVED
 - EXISTING 2' CONTOUR
 - EXISTING 10' CONTOUR
 - EXISTING INLET
 - EXISTING SANITARY MANHOLE
 - EXISTING SANITARY SEWER
 - EXISTING WATER MAIN
 - EXISTING WATER SERVICE
 - EXISTING GAS LINE
 - EXISTING FENCES
 - PERCOLATION TEST LOCATION
 - PROPOSED CONTOUR 2' INTERVAL
 - PROPOSED CONTOUR 10' INTERVAL
 - PROPOSED WATER SERVICE LINE
 - PROPOSED GAS LINE
 - PROPOSED SANITARY SEWER LATERAL
 - ROOF LEADER PIPE
 - PROPOSED SANITARY SEWER LATERAL CLEAN-OUT
 - PROPOSED 2'X2' INLET

DESIGN ENGINEERS CERTIFICATIONS:

- I hereby certify that the Stormwater Management Site Plan meets all design standards and criteria of the Haverford Township Stormwater Management Ordinance.
- The proposed grading activities shall not significantly increase stormwater runoff to, and/or otherwise adversely impact, downstream properties except as may be part of an approved Stormwater Management Plan (as defined by Haverford Township Code)
- The accuracy of this plan and details are in accordance with Act 367, known as the Professional Engineers Registration Law (P.L. 913, No. 367.63 P.S. 151), as amended.

I, Gustave N. Houtmann, P.E., on this date hereby certify, to the best of my knowledge and belief, that they aforementioned statements and certifications are true and accurate.

(Signature & Seal) _____ Date _____

The information shown on this plan is the result of a professional service rendered by G.D. Houtman & Son, Inc. Reproduction of this plan without approval of G.D. Houtman & Son, Inc. is not permitted. The reproduction of a copy of this plan for the purpose of creating additional copies or making any other use of the plan, in any form, is prohibited. Certification for the work contained herein is limited to the entity for whom the work was performed as of the date shown on the plans.

Note: All locations of existing utilities shown on the plan have been developed from existing utility records and / or above ground examination of the site. Completeness or accuracy of locations and depth of underground utilities or structures cannot be guaranteed. Contractor must verify location and depth of all underground utilities and facilities before start of work, as per PA Act 181 as per the latest amendment of PA Act 287 of 1974, Effective Mar. 28, 2007.

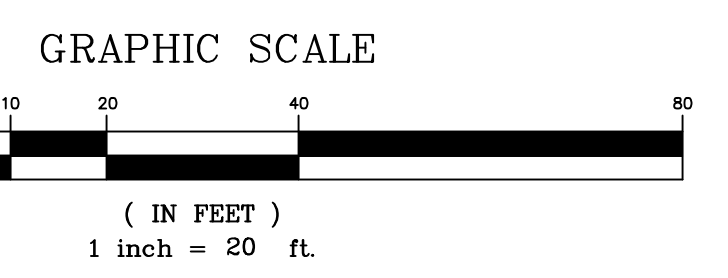

G. D. Houtman & Son, Inc. reserves its common law copyright and all other proprietary rights in these plans. All drawings, specifications and copies thereof are to remain property of G. D. Houtman & Son, Inc. They are to be used only in respect to this project. They are not to be assigned or represented to be suitable for reuse by owner or others on extensions of project or any other project. They are not to be assigned to any third party without first obtaining written permission by G.D. Houtman & Son, Inc. Any re-use without written permission for the specific purpose intended will be at the third party's sole risk and without liability or legal exposure to G. D. Houtman & Son, Inc. The third party shall further indemnify and hold harmless G. D. Houtman & Son, Inc. from all claims, damages, losses and expenses arising thereto or resulting therefrom.

These plans were prepared to obtain Subdivision/Land Development approval from the governing Municipality and to obtain certain permits from state and federal agencies. If a surveyor or engineer other than G. D. Houtman & Son, Inc. is contacted to perform construction stake-out services, soil survey or other engineering services, the responsibility for verifying dimensions, elevations, presence of underground utilities, utility interference, building size, etc. for coordinating information shown on lay-out plans, grading plans, utility plans, profiles, and details and for coordinating these plans with plans prepared by others such as utility companies, architectural building plans, landscape plans, lighting plans and etc.

DATE	REVISION
November 30, 2023	

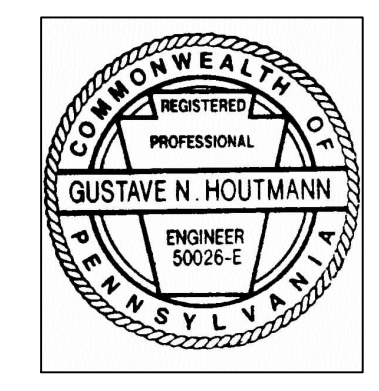

GRADING PLAN OF PROPERTY FOR
CARAMANICO HOMES, LLC
HAVERFORD TOWNSHIP
DELAWARE COUNTY, PA

G.D. HOUTMAN & SON, INC.
CIVIL ENGINEERS-LAND SURVEYORS
LAND PLANNERS
139 EAST BALTIMORE PIKE MEDIA, PA 19063
(610)565-4383

Sheet 3 of 6
PROJECT: Caramanico
WORK SHEET: 39258
FILE: 39258

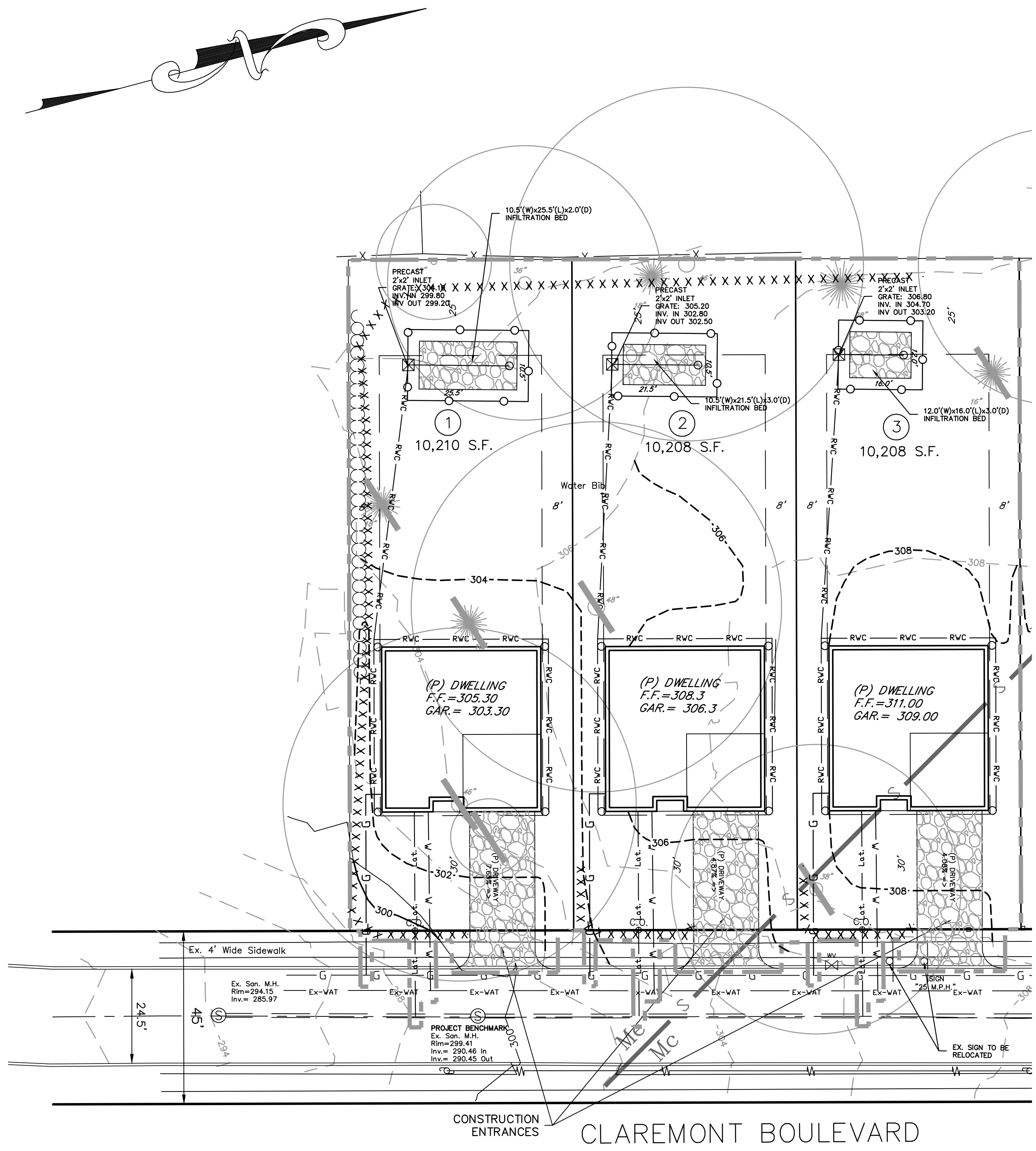

HOUSE CONSTRUCTION NOTES:

1. Install silt fence where shown on the plan. Install Construction Barrier Fencing at perimeter of infiltration beds. Construction vehicles shall not traverse over infiltration bed area. Infiltration bed areas shall remain undisturbed until bed is constructed.
2. Out in driveway, apply layer of crushed stone and maintain as construction access to the house site.
3. Construct house foundation. As soon as first floor decking is in place, backfill foundation and rough grade surrounding area.
4. Any topsoil stockpile generated by ITEMS 2 through 4 shall be placed in an area not subject to erosion and a silt fence barrier shall be installed and maintained around the downslope perimeter.
5. To all areas which earthmoving activities have ceased and will be subject to the action of earthmoving and other equipment, apply a mulch (wood chip - 2-3 tons per acre; hay or straw - 3 tons per acre). All other disturbed areas remaining open shall be temporarily seeded and mulched.
6. Contact the Township a minimum of 2 days Prior to the and Construct Infiltration Bed for roof drainage. Place orange construction fencing around infiltration bed area. Temporarily seal inlet grate with plywood and sealant. Sediment laden runoff must be prevented from flowing into the infiltration bed while the site remains disturbed.
7. Install underground utilities following procedures set forth in UTILITIES following final grading.
8. Complete house construction and discharge roof drains to infiltration bed system.
9. Permanent grass cover shall be established by seeding and mulching following final grading.
10. Driveway is to be stabilized with crushed stone or paving following the completion of the house construction. Stone filter berms may be incorporated into the driveway if relatively clean. Remove if choked with sediment.
11. Erosion and sediment control facilities are to be checked and properly maintained weekly and after each storm event. Sufficient quantities of silt fencing, crushed stone, straw bales, seeding and mulching should be readily available for remedial work if required.
12. Silt fencing may be removed when the site is stabilized. Accumulated sediment may be spread at the site in areas not subject to erosion.
13. The Contractor is advised to become familiar with the "Erosion and Sediment Pollution Control Program Manual" by the Commonwealth of PA., Department of Environmental Resources, April 2000 edition.
14. Copies of these plans must be available on site throughout construction.

SEEDING SPECIFICATIONS

- Disturbed areas on which activities have ceased must be stabilized immediately.
- I. Growing Season (March thru November 15)
 - A. Temporary Cover - for disturbed areas which are not at finished grade and which will be redisturbed within 1 year.
 1. Site Preparation: Apply 2 ton/acre of Agricultural grade limestone, plus fertilizer 50-50-50 per acre (50 lbs of N, 50 lbs of P2O5 and 50 lbs of K2O per acre) and work in where possible.
 2. Seeding: 50% Annual Ryegrass 50% Winter Rye. Apply at rate of 3lb/1000 S.F.
 3. Mulch: 3 tons per acre of small grain straw.
 - B. Permanent Cover - for disturbed areas at finish grade or will not be redisturbed within 1 year.
 1. Site Preparation: Re-apply topsoil to area. Apply 3 tons/acre of Agricultural grade Limestone plus Fertilizer 100-200-200 (100 lbs of N, 200 lbs of P2O5 and 200 lbs of K2O) and work in where possible.
 2. Seeding: 60% Kentucky Bluegrass
10% Perennial Ryegrass
30% Pennlawn Red Fescue
Apply at rate of 4 lb/1000 S.F.
 3. Mulch: 3 tons per acre of small grain straw.
 - II. Non-germinating Period (Nov 15 thru March 1)
 1. Apply mulch (3 tons per acre of small grain straw) to disturbed areas.
 2. Those areas that were stabilized by mulching only are to be limed, fertilized, seeded and mulched according to permanent or temporary seeding specifications at the end of the non-germinating period.

LEGEND

- | | | | |
|--|-------------------------------------|--|---|
| | EXISTING UTILITY POLE | | PERCOLATION TEST LOCATION |
| | EXISTING WATER VALVE | | PROPOSED CONTOUR 2' INTERVAL |
| | EXISTING DECIDUOUS TREE | | PROPOSED CONTOUR 10' INTERVAL |
| | EXISTING EVERGREEN TREE | | PROPOSED WATER SERVICE LINE |
| | DENOTES EXISTING TREE TO BE REMOVED | | PROPOSED GAS LINE |
| | EXISTING 2' CONTOUR | | PROPOSED SANITARY SEWER LATERAL |
| | EXISTING 10' CONTOUR | | ROOF LEADER PIPE |
| | EXISTING INLET | | PROPOSED SANITARY SEWER LATERAL CLEAN-OUT |
| | EXISTING SANITARY MANHOLE | | PROPOSED CONSTRUCTION FENCING |
| | EXISTING SANITARY SEWER | | PROPOSED SILT FENCE |
| | EXISTING WATER MAIN | | LIMIT OF DISTURBANCE (32,390 S.F.) |
| | EXISTING WATER SERVICE | | PROPOSED 2'X2' INLET |
| | EXISTING GAS LINE | | |
| | EXISTING FENCES | | |

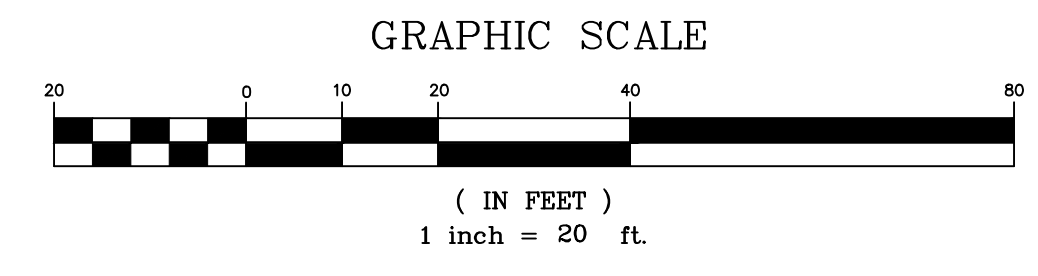

The information shown on this plan is the result of a professional service rendered by G.D. Houtman & Son, Inc. Reproduction of this plan without approval of G.D. Houtman & Son, Inc. is not permitted. The reproduction of a copy of this plan for the purpose of creating additional copies or retaining said plan shall, in no circumstance, be approved. Certification for the work contained herein is limited to the entity for whom the work was performed as of the date shown on the plans.

Note: All locations of existing utilities shown on the plan have been developed from existing utility records and / or above ground examination of the site. Completeness or accuracy of locations and depth of underground utilities or structures cannot be guaranteed. Contractor must verify location and depth of all underground utilities and facilities before start of work, as per PA Act 181 as amended by the latest amendment of PA Act 287 of 1974, Effective Mar. 28, 2007.

G. D. Houtman & Son, Inc. reserves its common law copyright and all other proprietary rights in these plans. All drawings, specifications and copies thereof are to remain property of G. D. Houtman & Son, Inc. They are to be used only in respect to this project. They are not to be assigned or represented to be suitable for reuse by owner or others on extensions of project or any other project. They are not to be assigned to any third party without first obtaining written permission by G.D. Houtman & Son, Inc. Any re-use without written permission for the specific purpose intended will be at the third party's sole risk and without liability or legal exposure to G. D. Houtman & Son, Inc. The third party shall further indemnify and hold harmless G. D. Houtman & Son, Inc. from all claims, damages, losses and expenses arising thereto or resulting therefrom.

These plans were prepared to obtain Subdivision/Land Development approval from the governing Municipality and to obtain certain permits from state and federal agencies. If a surveyor or engineer other than G. D. Houtman & Son, Inc. is contacted to perform construction stake-out services, said surveyor or engineer shall assume the responsibility for verifying dimensions, elevations, presence of underground utilities, utility interferences, building size, etc. for coordinating information shown on lay-out plans, grading plans, utility plans, profiles, and details and for coordinating these plans with plans prepared by others such as utility companies, architectural building plans, landscape plans, lighting plans and etc.

DATE	REVISION	SCALE 1" = 20' DATE November 30, 2023	SEDIMENT & EROSION CONTROL PLAN OF PROPERTY FOR CARAMANICO HOMES, LLC HAVERFORD TOWNSHIP DELAWARE COUNTY, PA	G.D. HOUTMAN & SON, INC. CIVIL ENGINEERS-LAND SURVEYORS LAND PLANNERS 139 EAST BALTIMORE PIKE MEDIA, PA 19063 (610)565-4383	Sheet 4 of 6
					PROJECT Caramanico WORK SHEET 39258 FILE 39258

TREE PROTECTION REQUIREMENTS

- Prior to any clearing or site disturbance, the Township requires a meeting with the applicant and/or site Contractor, to determine the methods to be implemented by the applicant to minimize tree loss. Application is required to follow standards as established in Section 170.
- All trees and other vegetation to be preserved shall be protected from damage by construction fencing or other effective barriers approved by the Township. Fencing or barriers around trees shall be placed outside the critical root zone, unless otherwise approved by the Township. Tree Protection fencing must be installed and approved by the Township prior to the start of any clearing or earth disturbance and monitored periodically. The tree protection fencing shall be removed only after all construction activities that may impact tree roots are completed.
- When disturbance within the critical root zone is unavoidable, applicants shall minimize encroachment and use the best available methods as approved by the Township to minimize damage and preserve trees. These methods may include, but shall not be limited to, utility tunneling, use of Geo-textiles, mulching, hand root pruning, and soil aeration. Applicants shall consult references such as a Guide to Preserving Trees in Development Projects, published by the Penn State College of Agricultural Sciences Cooperative Extension.

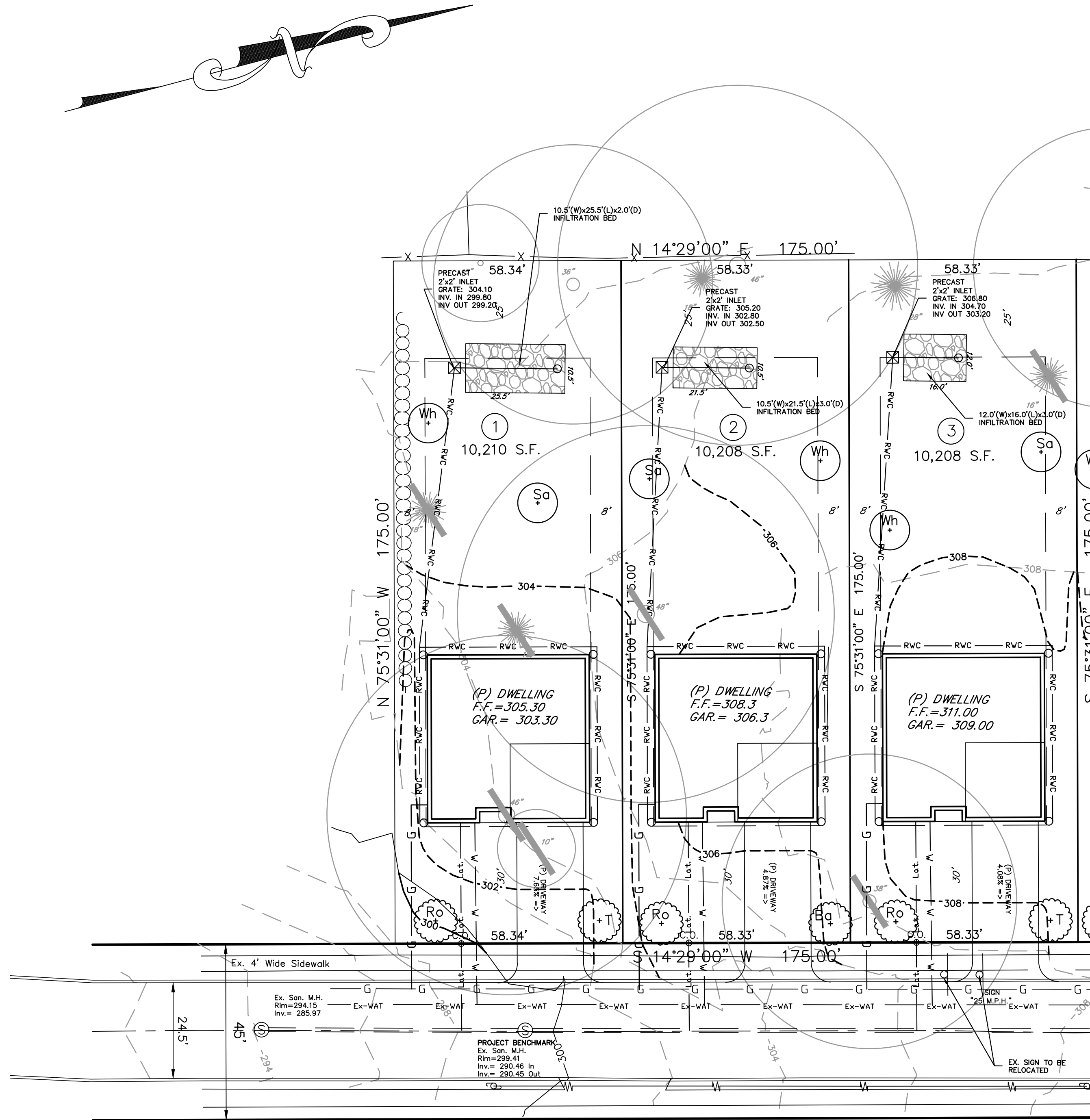
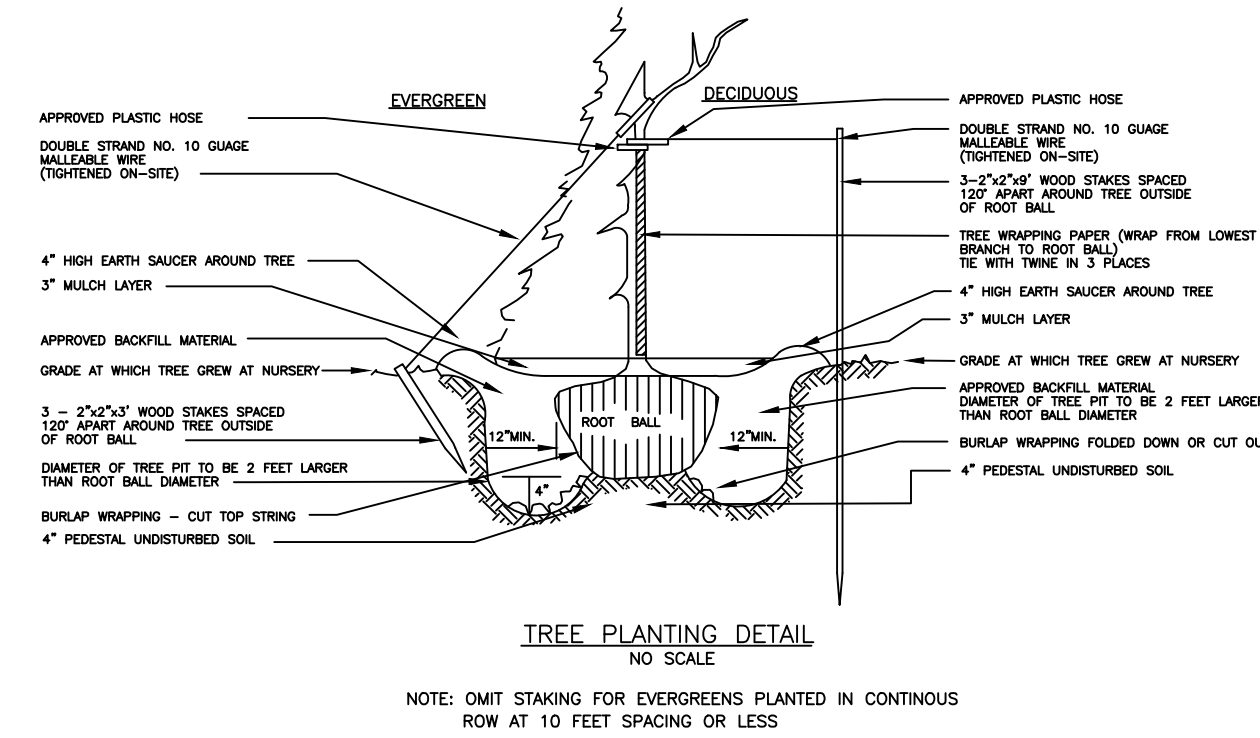

TREES TO BE REMOVED	TOTAL TREE REMOVAL (DBH)	SECTION 170-2.A&B REPLACEMENT REQUIREMENTS	REQUIRED TREE DIAM. REPLACEMENT	REQUIRED EQUIVALENT 2" DIAM. REPLACEMENT
LESS THAN 30" DBH (*)	62"	1" OF REPLACEMENT TREE DIAM. FOR EVERY 4" REMOVED	16"	8
10" - 1				
16" - 1				
18" - 2				
30" DBH AND GREATER	132"	1" OF REPLACEMENT TREE DIAM. FOR EVERY 1" REMOVED	132"	66
48" - 1				
46" - 1				
38" - 1				

GRAND TOTAL TREE REMOVAL = 7

(**) A Payment for Fee-In-Lieu of Tree Replacement Will Be Provided by the Developer for the 60 Replacement Trees Not Being Planted in Accordance with Section 170-4B.(7).

PROPOSED PLANTINGS:

STREET TREES:

SYMBOL	QUANTITY	BOTANIC/Common Name	SIZE	SPECS
Ro	3	Quercus rubra Red Oak	2.0" Cal.	B&B
Ba	1	Tilia americana Bosswood	2.0" Cal.	B&B
T	2	Liliodendron tulipifera Tulipwood	2.0" Cal.	B&B

PROPOSED NUMBER OF STREET TREES = 6

REPLACEMENT TREES:

SYMBOL	QUANTITY	BOTANIC/Common Name	SIZE	SPECS
Wh	3	Platanus occidentalis Sycamore	2.0" Cal.	B&B
Sa	3	Sassafras albidum Sassafras	2.0" Cal.	B&B

PROPOSED NUMBER OF REPLACEMENT TREES = 6

LANDSCAPING NOTES:

- Preservation: The landowner or developer shall protect trees to be retained from damage during construction. The following procedures shall be followed in order to so protect such trees:
 - Shade trees of twelve (12) inch caliper or more shall be preserved.
 - No more than five (5) inches of soil shall be placed around the trunks of trees, which are to remain. For those trees, which are to remain, where more than five (5) inches of soil are to be placed, tree wells shall be constructed to preserve such trees.
 - Trees to remain shall be protected by wooden silt snow fencing, placed around such trees. Fencing to be placed beyond the critical root zone of the tree(s) to be preserved (measured 12 times the trunk diameter or to the dripline, whichever is greater). Fencing shall be maintained throughout the construction period.
 - Trees shall not be used for roping, cables, signs, or fencing. Nails and spikes shall not be driven into trees.
 - Heavy equipment operators shall avoid damaging existing tree trunks and roots. Feeder roots shall not be cut or disturbed within the area circumscribed by the drip line of any tree.
 - No disturbance, material stockpiling, foot or vehicle traffic, excavation or fill shall be permitted within the critical root zone.
 - Tree limbs damaged during construction shall be sawed flush to tree trunks and treated with tree paints as necessary.
 - Deciduous trees shall be given a heavy application of fertilizer to aid in their recovery from possible damage caused by construction operations.
- Plant Characteristics and Maintenance
 - All plants shall conform to the "American Standards for Nursery Stock" of the American Association of Nurserymen.
 - Trees and shrubs shall be typical of their species and variety, have normal growth habits, well developed, densely foliated branches, and vigorous, fibrous root systems.
 - Trees and shrubs shall be free from defects and injuries and certified by appropriate Federal and State Authorities to be free from diseases and insect infestations.
 - Trees and shrubs shall be freshly dug and nursery grown. They shall have been grown under climatic conditions similar to those in the locality of the project or properly acclimated to conditions of the locality of the project.
 - The landowner or developer shall replace any tree or shrub, which dies within the term of a maintenance agreement. Any tree or shrub, which is deemed, in the opinion of the township, not to have survived or grown in a manner characteristic of its type, shall be replaced. Substitutions for certain species of plants may only be made when approved by the Board of Supervisors.
 - It shall be the responsibility of the landowners, tenants and/or other occupants of the premises to adequately and properly maintain the landscaped areas, which responsibility shall include watering, cleaning of weeds and debris, pruning and trimming, replacement of dead or diseased plantings, and fertilizing to maintain healthy growth.
 - All trees along the right-of-way of any property shall be kept trimmed nine (9) feet above any sidewalk and eleven (11) feet above all streets.
 - All shrubs and other growth abutting any sidewalks shall be kept cut back six (6) inches from the edge of the sidewalks.
 - Existing trees and shrubs at the corner of an intersection of streets and/or driveways, shall be cut to the height of 24 ins. from point of intersection of corner property lines back 50 ft. to avoid blocking sight distance to oncoming traffic; and shrubs or groundcovers to be planted shall be of the dwarf variety and shall not exceed 24 ins. height at maturity.

LEGEND

	EXISTING UTILITY POLE		PERCOLATION TEST LOCATION
	EXISTING WATER VALVE		PROPOSED CONTOUR 2' INTERVAL
	EXISTING DECIDUOUS TREE		PROPOSED CONTOUR 10' INTERVAL
	EXISTING EVERGREEN TREE		PROPOSED WATER SERVICE LINE
	DENOTES EXISTING TREE TO BE REMOVED		PROPOSED GAS LINE
	EXISTING 2' CONTOUR		PROPOSED SANITARY SEWER LATERAL
	EXISTING 10' CONTOUR		ROOF LEADER PIPE
	EXISTING INLET		PROPOSED SANITARY SEWER LATERAL CLEAN-OUT
	EXISTING SANITARY MANHOLE		
	EXISTING SANITARY SEWER		
	EXISTING WATER MAIN		
	EXISTING WATER SERVICE		
	EXISTING GAS LINE		
	EXISTING FENCES		

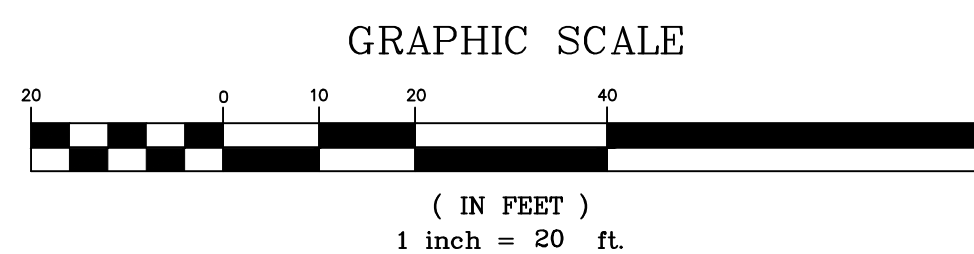

G. D. Houtman & Son, Inc. reserves its common law copyright and all other proprietary rights in these plans. All drawings, specifications and copies thereof are to remain property of G. D. Houtman & Son, Inc. They are to be used only in respect to this project. They are not intended or represented to be suitable for reuse by owner or others on extensions of project or any other project. They are not to be assigned to any third party without first obtaining written permission by G.D. Houtman & Son, Inc. Any re-use without written permission for the specific purpose intended will be at the third party's sole risk and without liability or legal exposure to G. D. Houtman & Son, Inc. The third party shall further indemnify and hold harmless G. D. Houtman & Son, Inc. from all claims, damages, losses and expenses arising thereto or resulting therefrom.

These plans were prepared to obtain Subdivision/Land Development approval from the governing Municipality and to obtain certain permits from state and federal agencies. If a surveyor or engineer other than G. D. Houtman & Son, Inc. is contacted to perform construction stake-out services, said surveyor or engineer shall assume the responsibility for verifying dimensions, elevations, presence of underground utilities, utility interference, building size, etc. for coordinating information shown on lay-out plans, grading plans, utility plans, profiles, and details and for coordinating these plans with plans prepared by others such as utility companies, architectural building plans, landscape plans, lighting plans and etc.

DATE	REVISION	SCALE	DATE	PROJECT
		1" = 20'	October 20, 2021	LANDSCAPE & TREE REPLACEMENT PLAN OF PROPERTY FOR CARAMANICO HOMES, LLC
				Sheet 5 of 6
				G.D. HOUTMAN & SON, INC. CIVIL ENGINEERS-LAND SURVEYORS 139 EAST BALTIMORE PIKE MEDIA, PA 19063 (610)985-4383

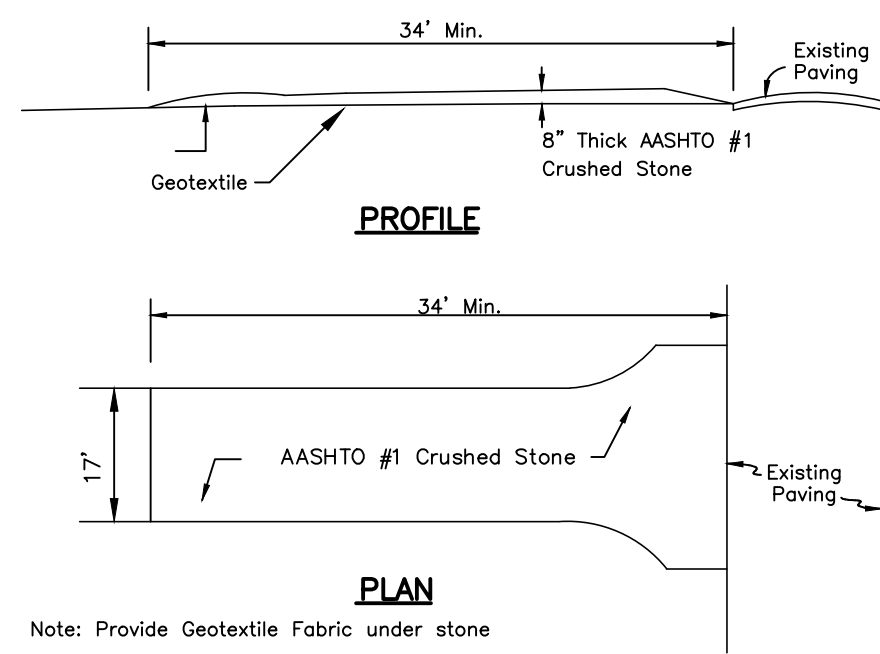

Note: Provide Geotextile Fabric under stone

- Maintenance Notes:
1. Rock Construction Entrance Thickness Shall Be Constantly Maintained To The Specified Dimensions By Adding Rock.
 2. A Stockpile Shall Be Maintained On-Site For This Purpose.
 3. At The End Of Each Construction Day, All Sediment Deposited On Paved Roadways Shall Be removed and Returned To The Construction Site.

CONSTRUCTION ENTRANCE - DETAIL

Note: Rock Construction entrance to be adjusted for site conditions as necessary

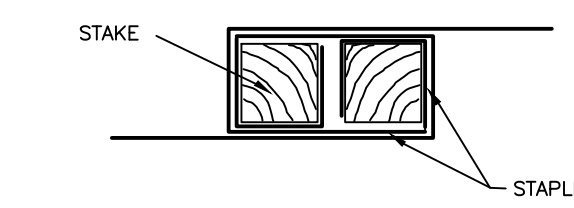

JOINING FENCE SECTIONS

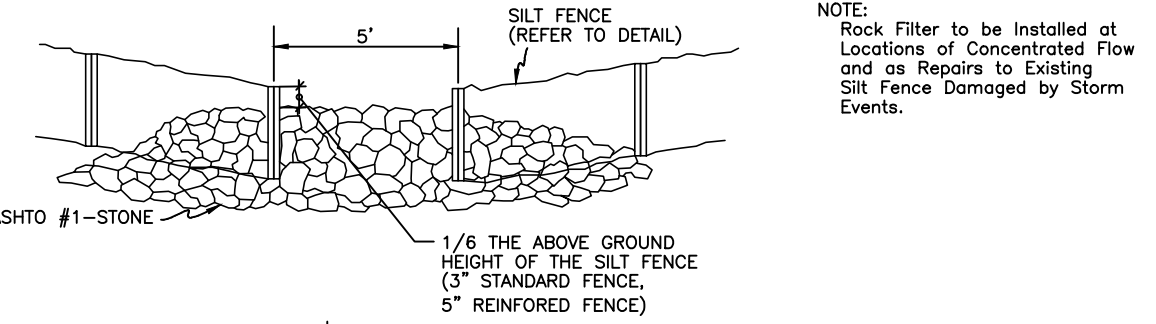

NOTE: Rock Filter to be installed at Locations of Concentrated Flow and as Repairs to Existing Silt Fence Damaged by Storm Events.

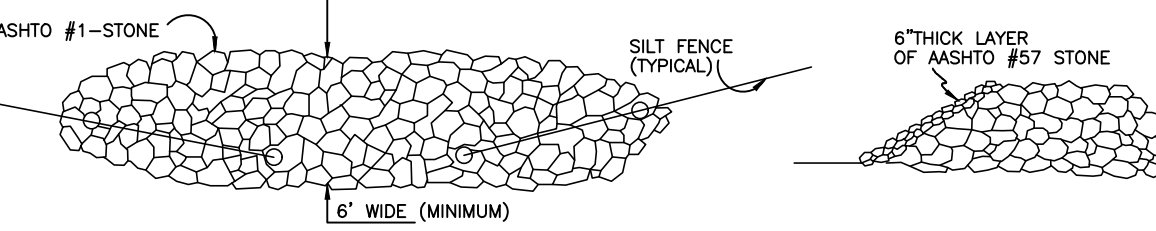

ROCK FILTER OUTLET FOR SILT FENCE

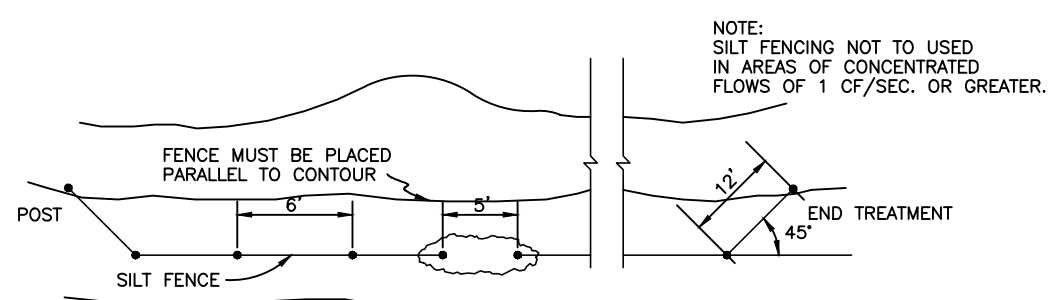

TEMPORARY SILT FENCE INSTALLATION

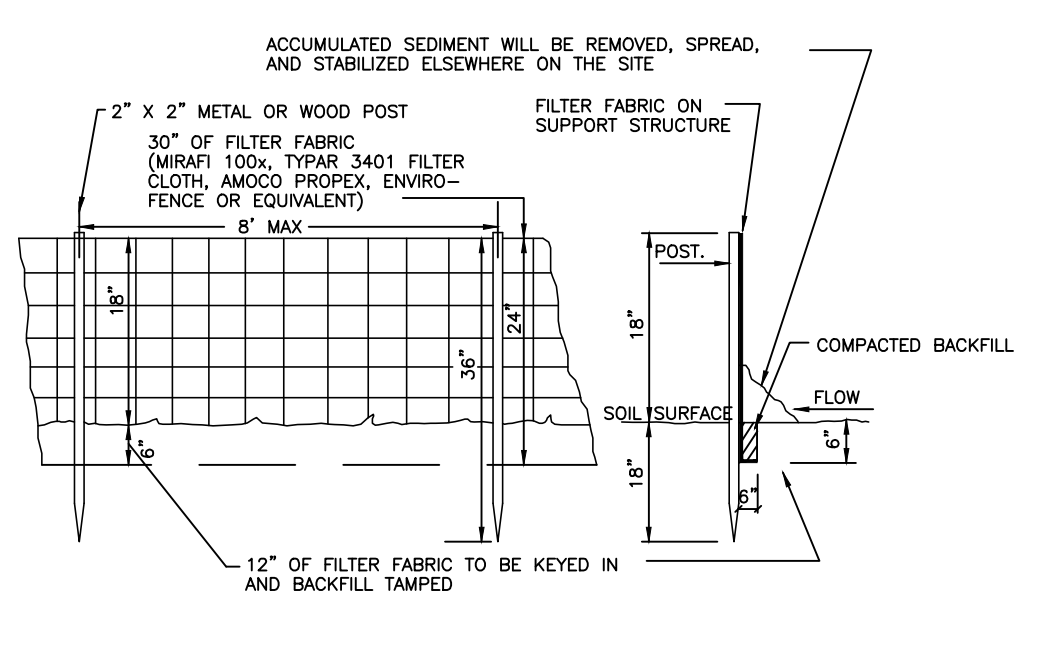

INSPECT SILT FENCING AFTER EACH STORM EVENT. REMOVE ACCUMULATED SEDIMENT WHEN IT REACHES A DEPTH OF 1/2 THE FABRIC HEIGHT (MAXIMUM 12"). ANY SILT FENCING WHICH HAS BEEN TOPPED OR UNDERMINED SHALL BE REPLACED WITH ROCK FILTER OUTLETS IMMEDIATELY.

TEMPORARY SILT FENCE DETAIL

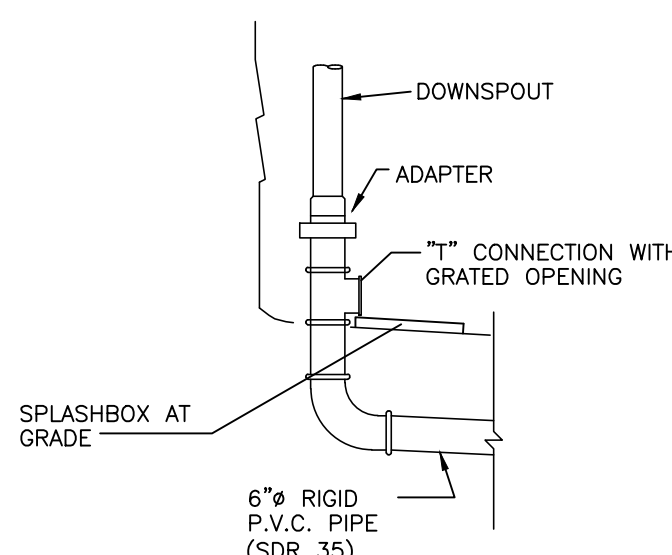

NOTE: ALL ROOF DRAINS FROM THE DWELLINGS SHALL BE DIRECTLY CONNECTED TO THE PROPOSED INFILTRATION BEDS AS SHOWN.

ROOF DRAIN CONNECTION DETAIL

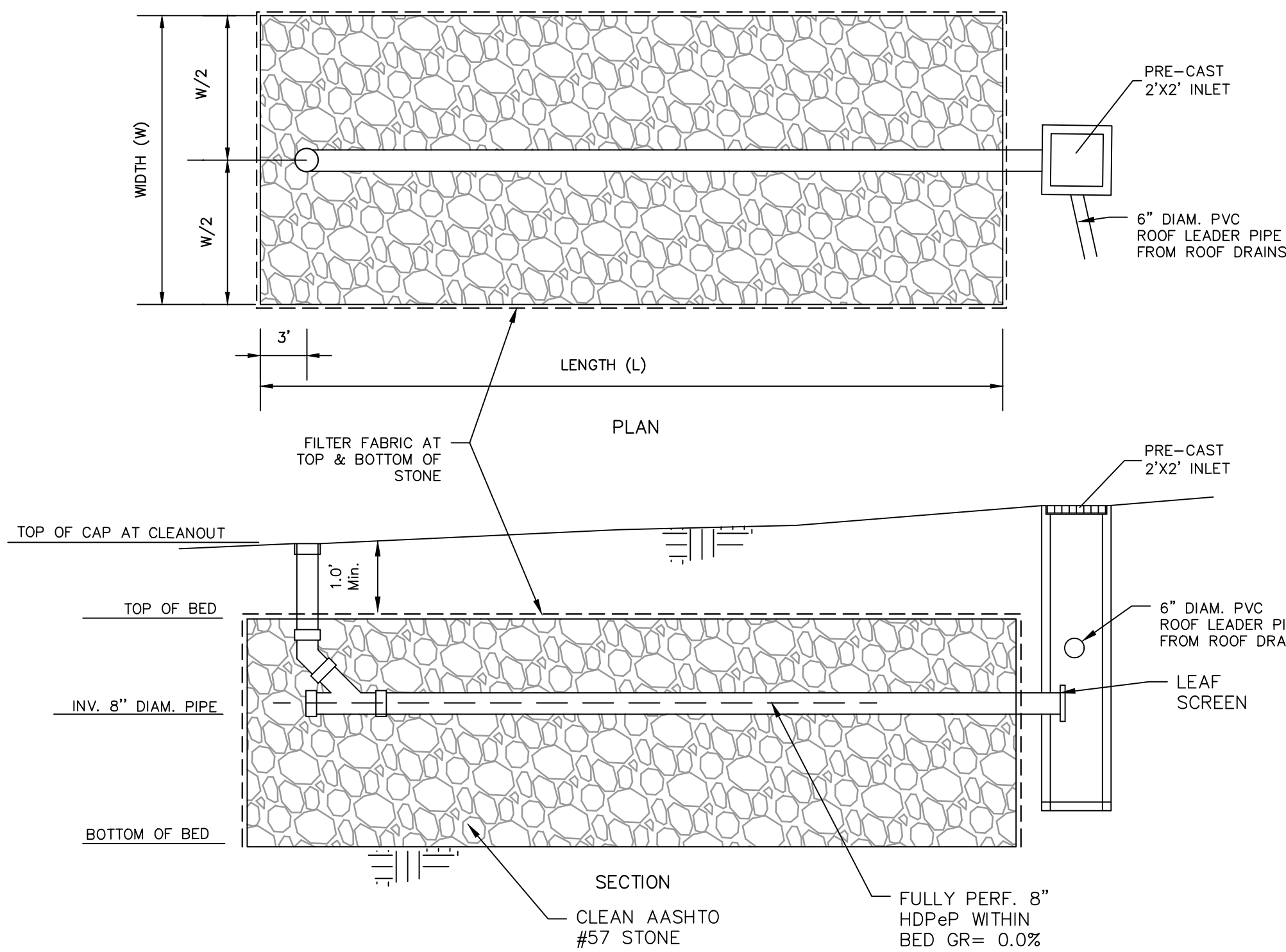

LOCATION	TOP OF GRATE ELEV.	INV. PIPE TO BED ELEV.	TOP OF BED ELEV.	BOTTOM OF BED ELEV.	BED LENGTH (L)	BED WIDTH (W)	BED DEPTH (D)	TOP OF CLEAN-OUT ELEV.
LOT #1	304.1	299.2	300.2	298.2	10.5'	25.5'	2.0'	304.7
LOT #2	305.2	302.5	304.0	301.0	10.5'	21.5'	3.0'	306.2
LOT #3	306.8	303.2	304.7	301.7	12.0'	16.0'	3.0'	306.7

- NOTES:
1. TOWNSHIP SHALL BE NOTIFIED A MINIMUM OF 48 HOURS PRIOR TO CONSTRUCTION FOR INSPECTION.
 2. ALL EQUIPMENT SHALL BE KEPT OFF INFILTRATION BED AREA TO PREVENT ANY COMPACTION.
 3. GEOTEXTILE SHALL BE PLACED AT ALL STONE/SOIL INTERFACES AT THE TOP AND SIDES OF THE INFILTRATION BED.
 4. ALL GEO-TEXTILE SHALL CONFORM TO P.A.D.O.T. CLASS 1 SPECIFICATIONS AND SHALL HAVE A MINIMUM OVERLAP OF 12".
 5. ALL STONE SHALL BE CLEAN WASHED AASHTO #57 STONE.
 6. ALL PIPE WITHIN STONE SHALL BE FULLY PERFORATED AND SHALL BE RIDGED SCHD. 40 PVC OR SDR 35 PIPE OR ADS N-12 PIPE. ALL OTHER PIPE SHALL BE RIGID SOLID SCHD 40 PVC, SDR 35 PIPE OR ADS N-12 PIPE.
 7. BOTTOM OF BED SHALL BE SCARIFIED PRIOR TO THE PLACEMENT OF STONE.
 8. ALL ROOF DRAINS SHALL BE PIPED DIRECTLY TO INFILTRATION BED.
 9. LEAF SCREEN SHALL BE PROVIDED ON ALL OUTLET PIPES TO INFILTRATION BED.

INFILTRATION BED DETAIL

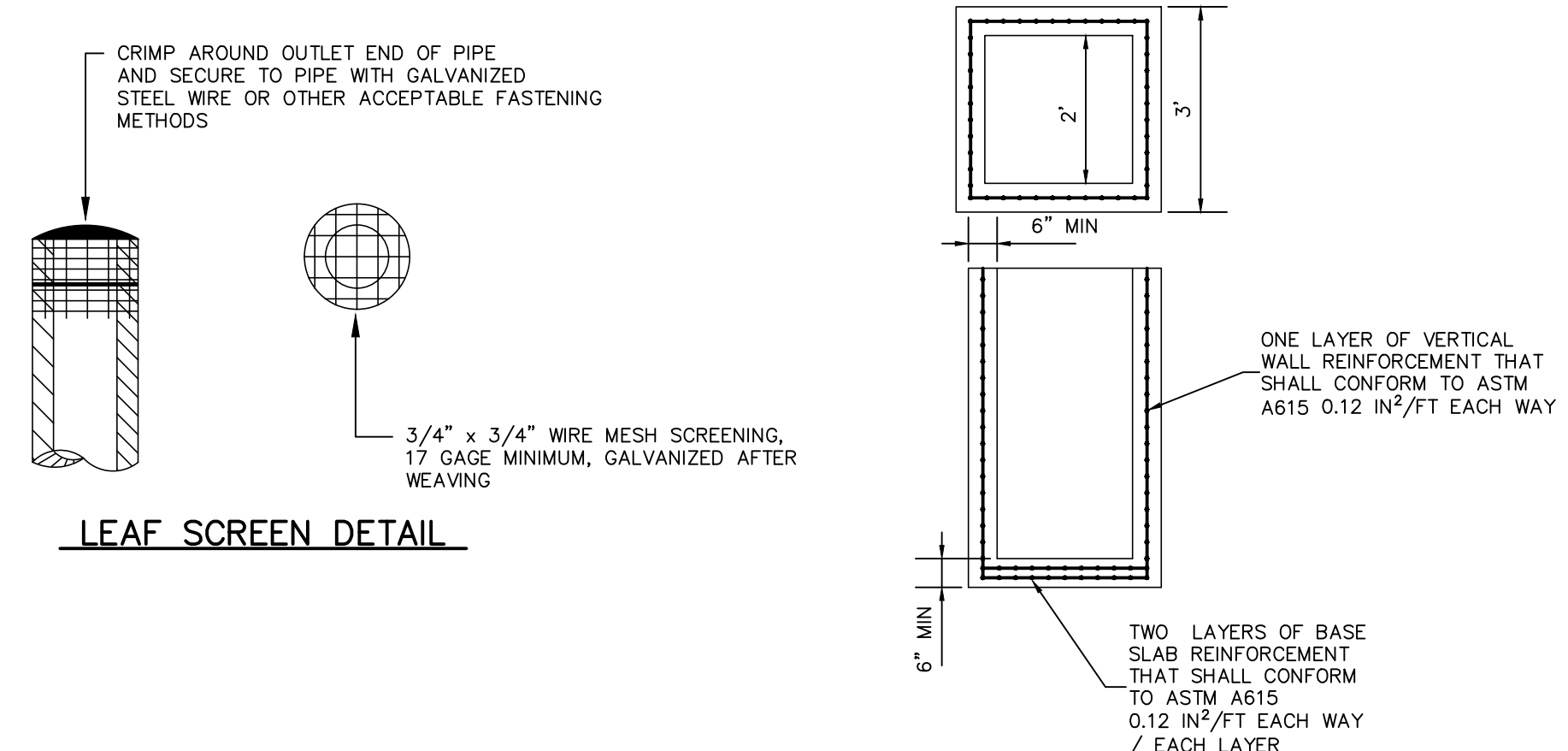

LEAF SCREEN DETAIL

- NOTES:
1. MATERIAL AND CONSTRUCTION SHALL COMPLY WITH PENN D.O.T. PUB. 408
 2. CLASS AA CONCRETE 4000 PSI @ 28 DAYS
 3. REINFORCEMENT SHALL COMPLY WITH ASTM A615

2'x2' PRE-CAST INLET DETAIL

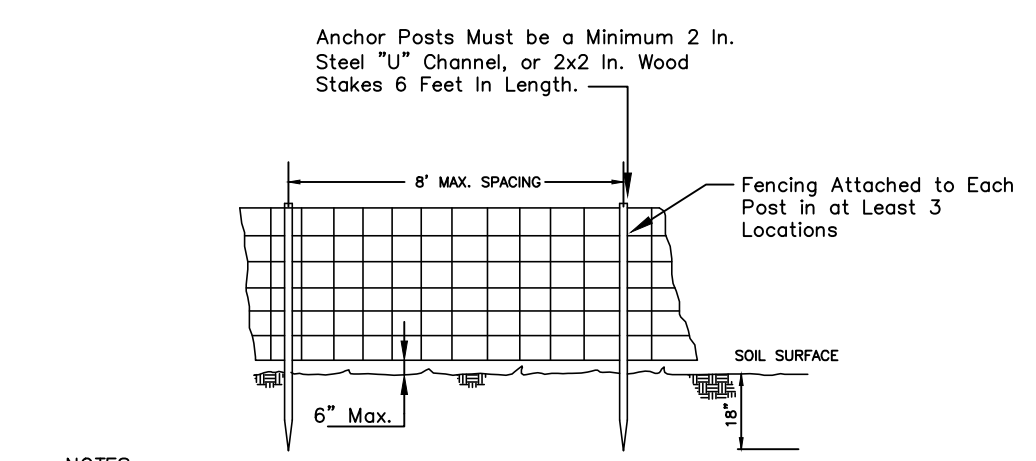

- NOTES:
1. Protection barrier to be installed at the dripline of proposed individual trees and protected forested areas.
 2. Anchor post to be driven into the ground at least 18 inches.
 3. Provide a maximum clearance between the protection barrier fencing and the ground surface of 6 inches.
 4. Protection barrier shall be 4 feet high, constructed of durable and highly visible material (Plastic orange construction fence and snow-fence may be used).
 5. Protection barriers shall be maintained throughout the duration of the work at the site.
 6. Additional warning signs should also be placed on the fencing and in appropriate areas near the work zone.

TREE PROTECTION/CONSTRUCTION FENCING DETAIL

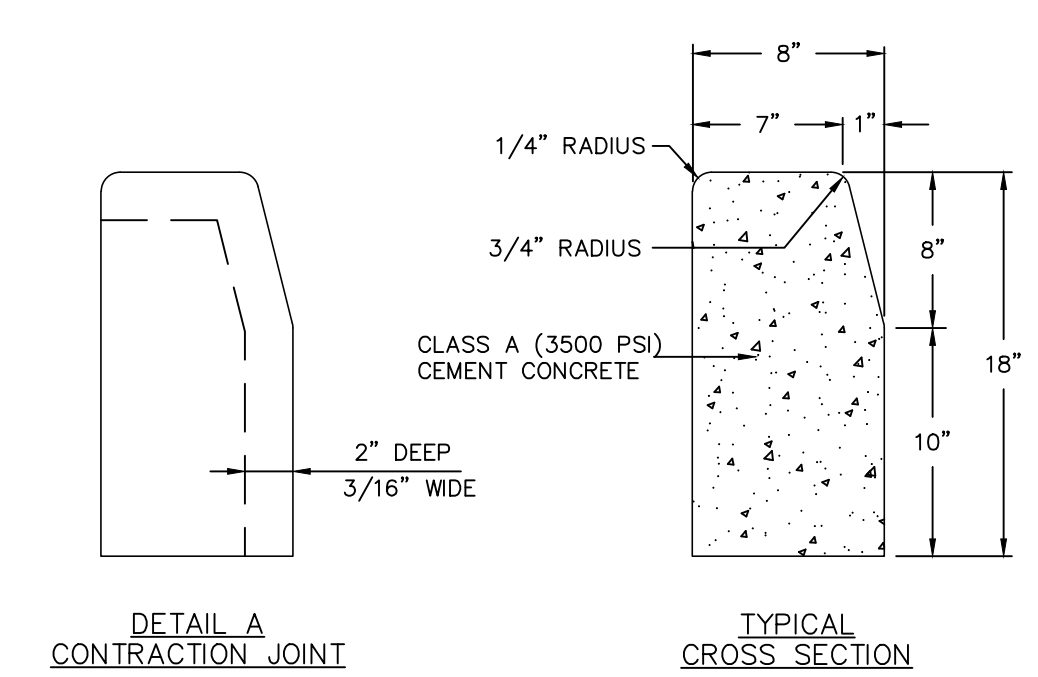

DETAIL A CONTRACTION JOINT

TYPICAL CROSS SECTION

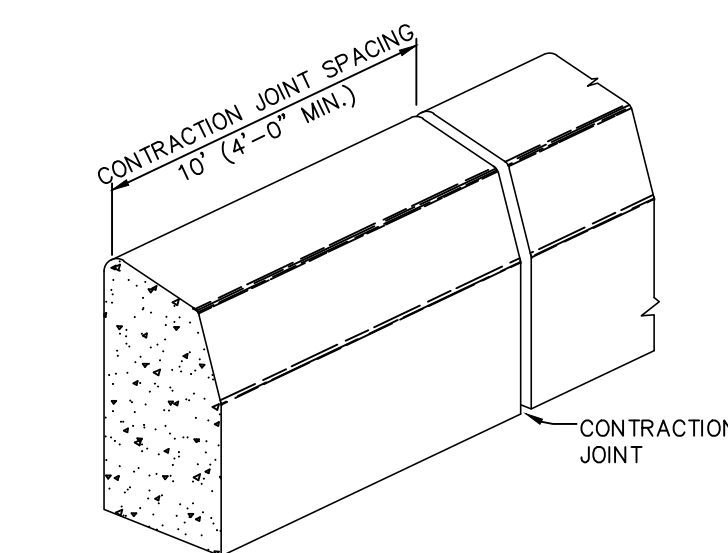

PLAIN CEMENT CONCRETE CURB

NOT TO SCALE

NOTE: Concrete to have minimum 28 day compressive strength of 3,750 psi.

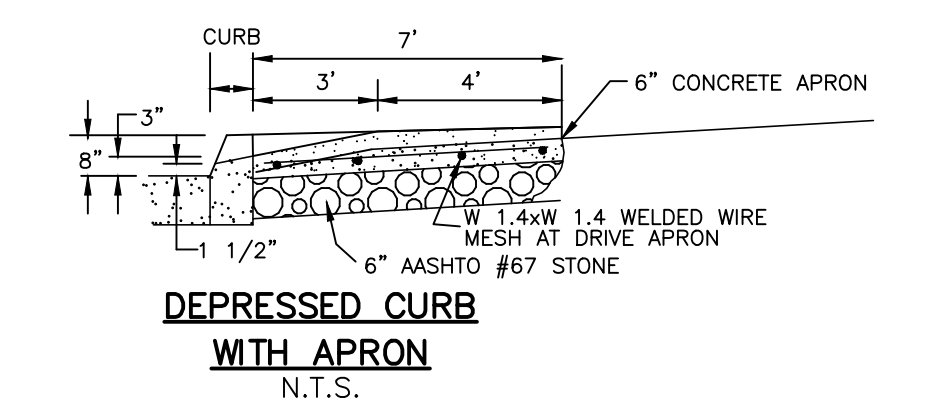

DEPRESSED CURB WITH APRON

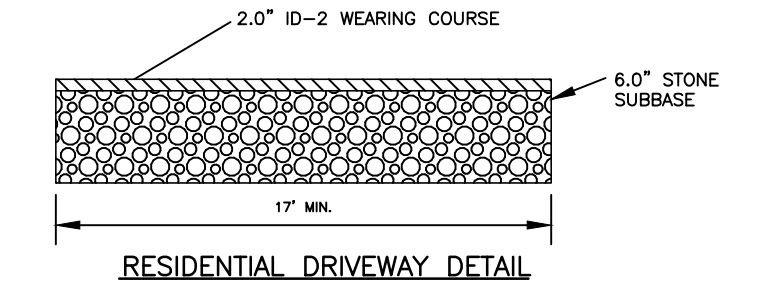

RESIDENTIAL DRIVEWAY DETAIL

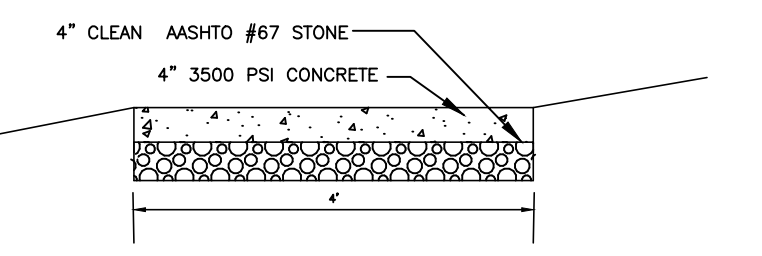

SIDEWALK DETAIL

NOTE: Concrete to have minimum 28 day compressive strength of 3,750 psi.

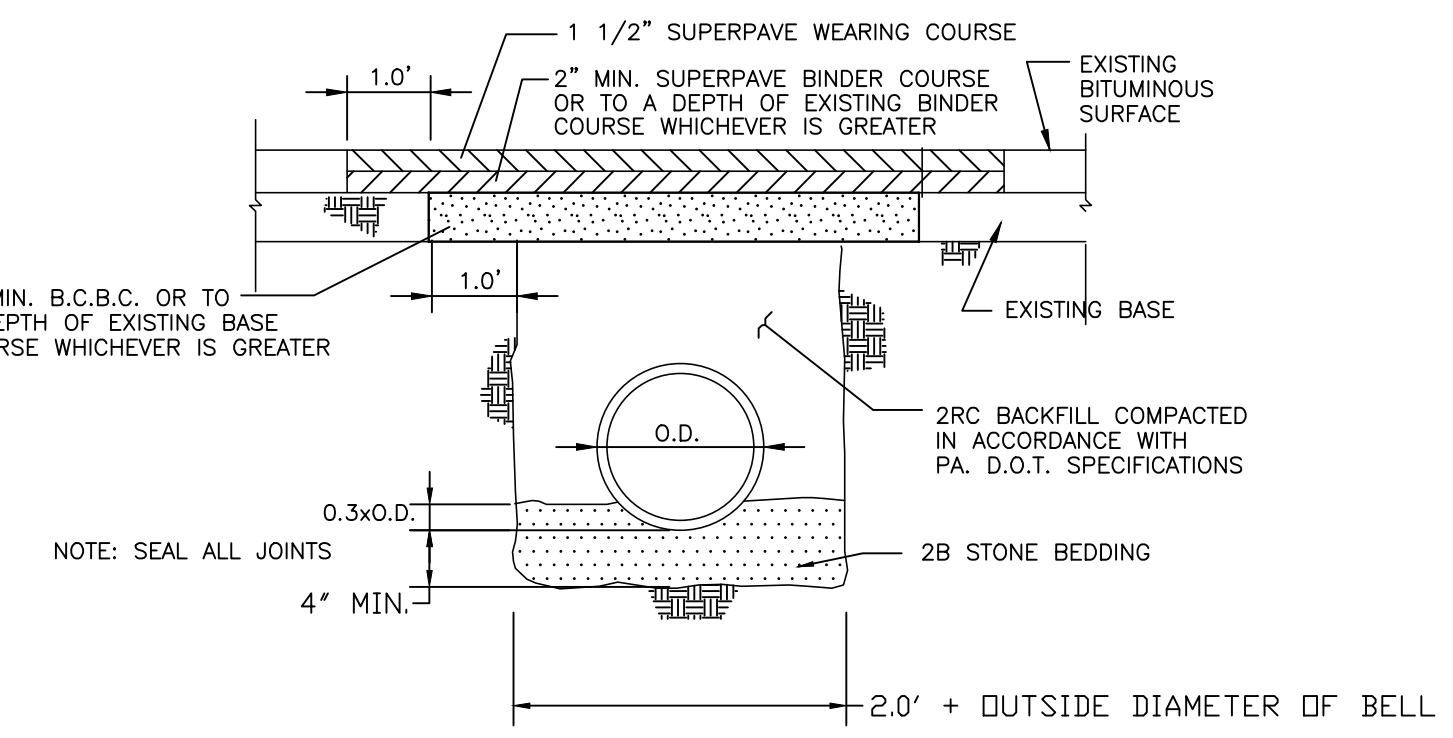

TOWNSHIP ROAD TRENCHING AND RESTORATION DETAIL

NOTE: EXPOSED VERTICAL AND HORIZONTAL SURFACES SHALL BE PREPARED AS PER PUB. 408, SECT. 401.3(f).

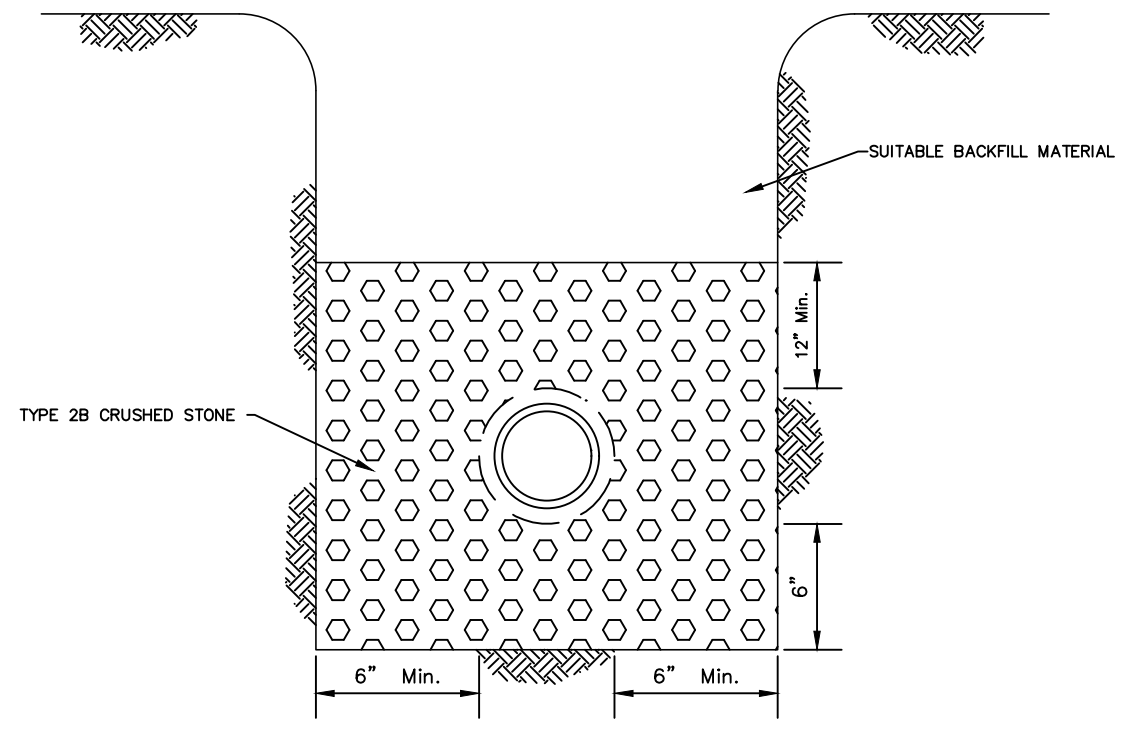

TYPICAL SANITARY SEWER BEDDING DETAIL

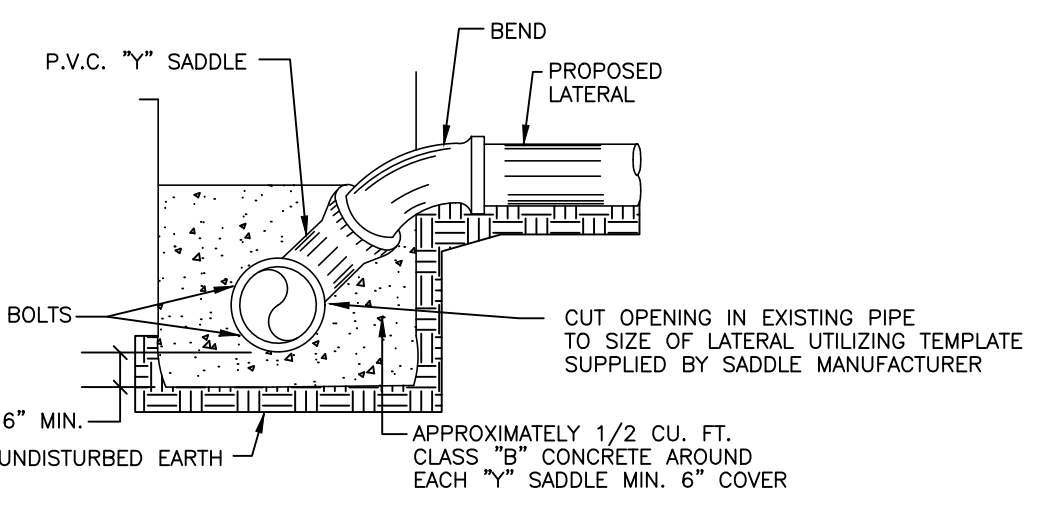

NOTE: SERVICE BEND AND Y BRANCH SHALL BE EITHER 4\"/>

\"/>

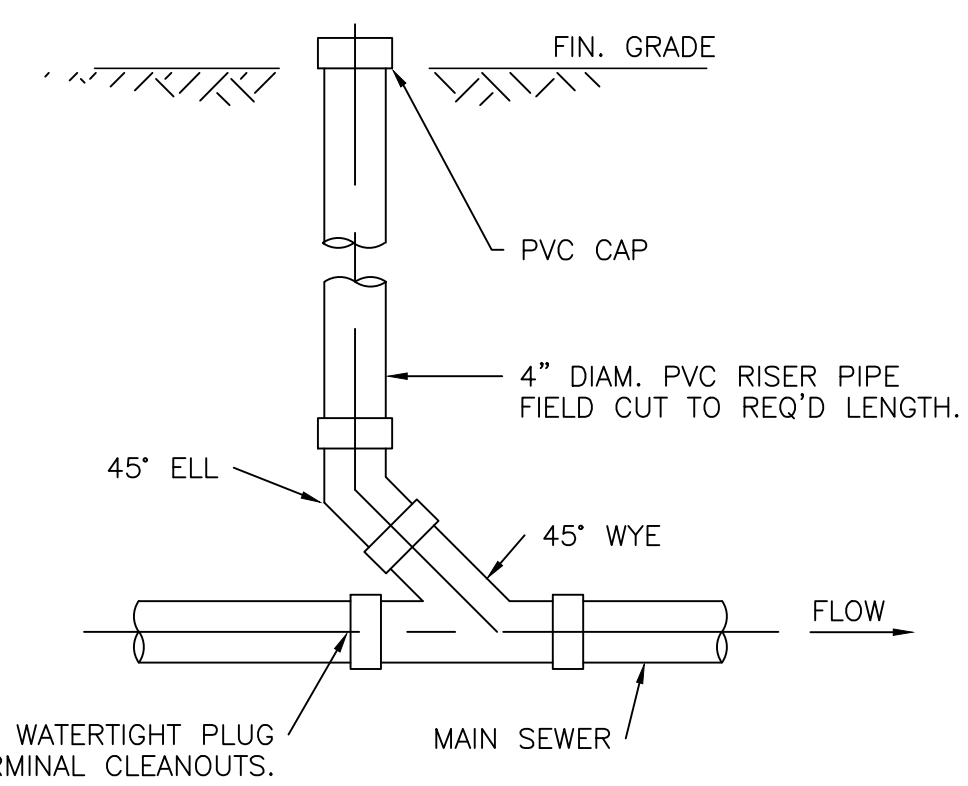

CLEANOUT DETAIL

NOT TO SCALE

G. D. Houtman & Son, Inc. reserves its common law copyright and all other proprietary rights in these plans. All drawings, specifications and copies thereof are to remain property of G. D. Houtman & Son, Inc. They are to be used only in respect to the project they are not to be assigned to any third party without first obtaining written permission by G.D. Houtman & Son, Inc. Any re-use without written permission for the specific purpose intended will be at the third party's sole risk and without liability or legal exposure to G. D. Houtman & Son, Inc. The third party shall further indemnify and hold harmless G. D. Houtman & Son, Inc. from all claims, damages, losses and expenses arising thereto or resulting therefrom.

These plans were prepared to obtain Subdivision/Land Development approval from the governing Municipality and to obtain certain permits from state and federal agencies. If a surveyor or engineer other than G. D. Houtman & Son, Inc. is contracted to perform construction stake-out services, said surveyor or engineer shall assume the responsibility for verifying dimensions, elevations, presence of underground utilities, utility interference, building size, etc. for coordinating information shown on lay-out plans, grading plans, utility plans, profiles, and details and for coordinating these plans with plans prepared by others such as utility companies, architectural building plans, landscape plans, lighting plans and etc.

The information shown on this plan is the result of a professional service rendered by G.D. Houtman & Son, Inc.. Reproduction of this plan without approval of G.D. Houtman & Son, Inc. is not permitted. The reproduction of a copy of this plan for the purpose of creating additional copies or retaining said plan shall, in no circumstance, be approved. Certification for the work contained herein is limited to the entity for whom the work was performed as of the date shown on the plans.

Note: All locations of existing utilities shown on the plan have been developed from existing utility records and / or above ground examination of the site. Completeness or accuracy of locations and depth of underground utilities or structures cannot be guaranteed. Contractor must verify location and depth of all underground utilities and facilities before start of work, as per PA Act 181 as per the latest amendment of PA Act 287 of 1974, Effective Mar. 28, 2007.

DATE	REVISION	SCALE
		None
		DATE
		November 30, 2023

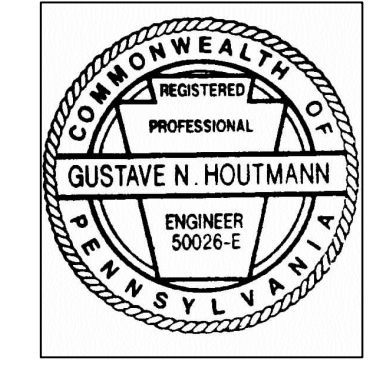

CONSTRUCTION DETAILS PLAN OF PROPERTY FOR

CARAMANICO HOMES, LLC

Haverford Township Delaware County, PA

G.D. HOUTMAN & SON, INC. Sheet 6 of 6

CIVIL ENGINEERS-LAND SURVEYORS LAND PLANNERS

139 EAST BALMORE PIKE MEDIA, PA 19063 (610)585-4383

PROJECT WORK SHEET Caramanico 39258 FILE 39258



TOWNSHIP OF
HAVERFORD

DELAWARE COUNTY
1014 DARBY ROAD
HAVERTOWN, PA 19083-2551
(610) 446-1000

LARRY HOLMES, ESQ, PRESIDENT
JUDY TROMBETTA, VICE PRESIDENT
DAVID R. BURMAN, TWP MANAGER/SECRETARY
AIMEE CUTHBERTSON, ASS'T TWP. MANAGER
JOHN R. WALKO ESQ., SOLICITOR
PENNONI ASSOCIATES, INC. ENGINEER

WARD COMMISSIONERS
1ST WARD BRIAN D. GONDEK
2ND WARD SHERYL FORSTE-GRUPP, PH.D
3RD WARD KEVIN MCCLOSKEY, ESQ
4TH WARD JUDY TROMBETTA
5TH WARD LAURA CAVENDER
6TH WARD LARRY HOLMES, ESQ
7TH WARD CONOR QUINN
8TH WARD GERARD T. HART, MD
9TH WARD WILLIAM F. WECHSLER

Manager 610-446-1000 ext. 2208
Human Resources 610-446-1000 ext. 2233

January 4, 2024

HAVTT 30251

Gary Smith, Zoning Officer
Haverford Township
1014 Darby Road
Havertown, PA 19083-2251

**RE: Minor Subdivision Plan
Caramanico Homes, LLC – 14 Claremont Boulevard**

Dear Mr. Smith:

As requested, we have reviewed the following prepared by G.D. Houtman & Son, Inc. in connection with the referenced property:

- *"Caramanico Homes, LLC"* (six sheets) dated November 30, 2023.
- *"Stormwater Management Calculations for Caramanico Homes, LLC, 14 Claremont Boulevard"* dated November 30, 2023.

The applicant, Caramanico Homes LLC, proposes to subdivide an existing 30,625 square foot lot (folio no. 22-09-00355-00) into three (3) new lots at the referenced property. A new single-family dwelling and driveway are proposed on each lot. Individual infiltration beds on each lot are proposed for stormwater management. The property is within the R-5 Residential Zoning District.

The applicant has requested the following waiver:

- From §160-4 requiring a two-step preliminary/final land development plan review process.

We offer the following comments:

ZONING

1. The applicant should confirm conformity of proposed setback lines with the median setback lines of existing structures on the same side of the street and within 300 feet of the proposed new construction. (§182-715)
2. A complete zoning compliance table showing proposed setbacks, impervious coverage, etc. shall be provided. (§160-4.E(5))
3. Two (2) parking spaces, measuring a minimum of 9 feet wide and 18 feet long, are required for each single-family dwelling (§182-707.B, §182-707.A(1)) The applicant should confirm that the required parking has been provided.

SUBDIVISION AND LAND DEVELOPMENT

4. The minimum right-of-way width for residential/minor collector streets is 50-feet. (160-5.B(3)[j](1)) The Township may require an additional 2.5 feet of right-of-way for the length of the property.
5. Signature blocks for the Township, Township Planning Commission and Township Engineer should be provided on the plan. (160-4.H(1)[e])
6. Permanent survey monuments located on the right-of-way lines at corners and at angle points are required to be indicated on the plan. (160-5.B(8))
7. In each residential district involving the creation of two (2) or more new building lots, land shall be required to be set aside for open space and/or parks and recreational facilities, or a fee-in-lieu requested. (160-5.C(2,4))

STORMWATER MANAGEMENT

8. A Drainage Plan Application and Checklist are required to be submitted. (§78-25.A.(6,7))
9. The proposed yard inlets should indicate a one (1) foot sump. (78-30.K)
10. All perimeter fence should be super silt fence.
11. Inlet protection should be provided for the proposed yard inlets. (78-25.B(20))
12. Proposed electric services should be indicated on the plan. (§78-25.B(5))
13. Topsoil stockpile locations should be indicated on the plan. (§78-25.B(20))
14. A BMP Maintenance Agreement shall be executed and a contribution of \$2,200.00 per lot to the Township Stormwater Control and BMP Operation and Maintenance Fund shall be made. (§78-49, §78-51)

GENERAL

15. A Sewage Facilities Planning module or exemption will be required. (§160-4.E(5[d]))
16. A foundation as-built plan will be required to confirm the proposed buildings are within the required building envelope.
17. The plans should indicate the location of the existing sanitary sewer lateral and whether it is to be re-used or abandoned.
18. The wye saddle detail shall be revised to reflect a cast iron saddle in lieu of PVC.
19. It appears portions of the existing stone wall along the southeast corner of the property are on the adjacent property. The applicant should indicate how the wall will be retained or reconstructed.
20. The sidewalk detail should be revised to indicate a minimum 3750 psi concrete. (Township Design Standards)
21. A curb opening detail indicating a minimum longitudinal length of depressed curb of 14 feet should be provided on the plan. (Township Design Standards)

22. A leveling area of not less than 20 feet in length and not greater than 4% in grade shall be provided at the end of the driveway at the street line for all driveways exceeding 6% in grade. (Township Design Standards)
23. A Township Road Opening Permit will be required for the driveway and utility installations.
24. Roadway restoration shall conform to the requirements §157-30 and the road restoration detail revised accordingly.
25. Tree protection fencing should be indicated for trees proposed to remain.
26. A tree removal permit is required for removal of the existing trees on site. (§170-4.B) All proposed landscaping and tree replacement should be reviewed by the Township Shade Tree Commission.

Should you have any further questions or comments, please contact the undersigned.

Sincerely,

PENNONI



Charles Faulkner, PE
Senior Engineer

CF/brg

cc: Caramanico Homes LLC
Gustave N. Houtmann, PE – G.D. Houtman & Son, Inc.



DELAWARE COUNTY PLANNING COMMISSION

2 W. Baltimore Avenue – Suite 202

Media, PA 19063

(610) 891-5200

Email: planning_department@co.delaware.pa.us

GINA BURRITT

DIRECTOR

Planning Department

January 19, 2024

Mr. David R. Burman
Haverford Township
1014 Darby Road
Havertown, PA 19083

RE: Name of Dev't: Caramanico Homes - 14 Claremont
DCPD File No.: 20-7936-24
Developer: Caramanico Homes
Location: East side of Claremont Blvd,
approximately 200' south of West Chester
Pike
Recv'd in DCPD: December 28, 2023

Dear Mr. Burman:

In accordance with the provisions of Section 502 of the Pennsylvania Municipalities Planning Code, the above described proposal has been sent to the Delaware County Planning Commission for review. At a meeting held on January 18, 2023, the Commission took action as shown in the recommendation of the attached review.

Please refer to the DCPD file number shown above in any future communications related to this application.

Very truly yours,

Gina Burritt
Director

cc: Caramanico Homes
G. D. Houtman and Son

2 W. Baltimore Avenue - 2nd Floor
Media, PA 19063
Phone: (610) 891-5200
Email: planning_department@co.delaware.pa.us

Date: January 19, 2024
File No.: 20-7936-24

PLAN TITLE: Caramanico Homes - 14 Claremont

DATE OF PLAN: November 30, 2023

OWNER OR AGENT: Caramanico Homes

LOCATION: East side of Claremont Blvd,
approximately 200' south of West
Chester Pike

MUNICIPALITY: Haverford Township

TYPE OF REVIEW: Final Subdivision and Land
Development

ZONING DISTRICT: R-5

SUBDIVISION ORDINANCE: Local

PROPOSAL: Subdivision: Subdivide 0.703 acre
into three lots

Land Development: Develop three
single-family detached dwellings

UTILITIES: Public

RECOMMENDATIONS: Approval, with consideration given
to staff comments

STAFF REVIEW BY: Michael A. Leventry

REMARKS:

CURRENT PROPOSAL

The plan proposes to subdivide one parcel into three and subsequently develop three single-family detached dwellings.



Date: January 19, 2024
File No.: 20-7936-24

REMARKS (continued):

SITE CHARACTERISTICS

The site fronts onto a local street and is currently undeveloped (a prior home and garage have been demolished).

APPLICABLE ZONING

The proposal is located within the R-5 district and is subject to applicable regulations set forth by the Municipal zoning code.

COMPLIANCE

The proposal appears to comply with the R-5 district provisions.

WAIVERS

The applicant is seeking the following waiver relief:

- Section 160-3E: To allow a combined preliminary/final plan submission.

Staff has no comment related to this waiver request.

HISTORICAL AND ARCHEOLOGICAL SIGNIFICANCE

The historically significant Fairview Acres at 14 Claremont Blvd. has already been demolished. It is on the 1994 Historic Resource Survey and should have been retained or documented prior to demolition. The Township should notify the Historical Commission of demolition permits for buildings such as this to avoid unnecessarily losing more of the Township's heritage.

The area of the house and the outbuildings has a high potential for underground resources and if any artifacts are found, the applicant should contact DCPD for a short documentation process.

Date: January 19, 2024
File No.: 20-7936-24

REMARKS (continued):

SEWAGE FACILITIES

The developer should contact the Pennsylvania Department of Environmental Protection regarding the need for sewage facilities planning approval.

The Municipality should confirm receipt of any necessary Pennsylvania Department of Environmental Protection planning approval prior to final approval.

STORMWATER MANAGEMENT

The Municipal Engineer must verify the adequacy of all proposed stormwater management facilities.

RECORDING

In accordance with Section 513(a) of the Pennsylvania Municipalities Planning Code (MPC), final plans must be recorded within ninety (90) days of municipal approval.

Resolution No. 2362-2024

American Rescue Plan Act
Coronavirus Local Fiscal Recovery Fund
Police Electric Vehicles

WHEREAS, Haverford Township's direct allocation from the Coronavirus State and Local Fiscal Recovery Fund was \$19.8 million;

WHEREAS, on April 1, 2022, the U.S. Department of Treasury released the Final Rule covering the Coronavirus State and Local Fiscal Recovery Fund, as created and directed by the American Rescue Plan Act authorizing recipients to use funds to invest in public health improvements, economic recovery and development, services to disproportionately affected communities, and general government services, among other allowable purposes; and,

WHEREAS, the Board of Commissioners desires to make improvements and financial investments in several Township projects and initiatives in accordance with the allowable spending structure as described by the U.S. Department of Treasury's Final Rule, as follows:

Purchase 2024 Landmaster AMP crew 4x4 electric ATV for a total funding allocation of \$23,699

Now, therefore, be it resolved, that the Board of Commissioners of Haverford Township hereby approves the use of funds from the Township's American Rescue Plan Fund allocation for the above referenced projects and initiatives.

Resolved this 12th day of February, 2024.

Township of Haverford
By:
C. Lawrence Holmes, Esq.
President

Attest:
David R. Burman
Township Manager/Secretary

Township of Haverford - Resolution No. 2363-2024

Request for Funding under the Commonwealth of Pennsylvania, Department of Community and Economic Development, COVID-19 ARPA Capital Projects Fund Multi-Purpose Community Facilities Program – Maker’s Space/Innovation Zone at Haverford Township Free Library Project.

Be it Resolved, that the Board of Commissioners of the Township of Haverford of Delaware County hereby acknowledges its support for an application to the Commonwealth of Pennsylvania, Department of Community and Economic Development, COVID-019 ARPA Capital Projects Fund Multi-Purpose Community Facilities Program in the amount of \$268,750 to assist with the construction and technology outfitting of the Maker’s Space/ Innovation Zone to be located within the newly renovated Haverford Township Free Library.

Be it Further Resolved, that the Applicant does hereby designate David R. Burman, Township Manager and Aimee M Cuthbertson, Assistant Township Manager as the officials to execute all documents and agreements between the Township of Haverford and the Department of Community and Economic Development to facilitate and assist in obtaining the requested grant.

Township of Haverford

By:

C. Lawrence Holmes, Esq.
President

Attest:

David R. Burman
Township Manager/Secretary

Township of Haverford - Resolution No. 2364-2024

Request for Funding under the Commonwealth of Pennsylvania, Department of Community and Economic Development, COVID-19 ARPA Capital Projects Fund Multi-Purpose Community Facilities Program – Haverford Township Skatium Project

Be it Resolved, that the Board of Commissioners of the Township of Haverford of Delaware County hereby acknowledges its support for an application to the Commonwealth of Pennsylvania, Department of Community and Economic Development, COVID-019 ARPA Capital Projects Fund Multi-Purpose Community Facilities Program in the amount of \$500,000 to assist with the space planning, construction and renovation of the locker rooms and related space at the Haverford Township Skatium.

Be it Further Resolved, that the Applicant does hereby designate David R. Burman, Township Manager and Aimee M Cuthbertson, Assistant Township Manager as the officials to execute all documents and agreements between the Township of Haverford and the Department of Community and Economic Development to facilitate and assist in obtaining the requested grant.

Township of Haverford

By:

C. Lawrence Holmes, Esq.
President

Attest:

David R. Burman
Township Manager/Secretary

Township of Haverford - Resolution No. 2365-2024

American Rescue Plan Act
Coronavirus Local Fiscal Recovery Fund
Public Works Heavy Equipment

Whereas, Haverford Township's direct allocation from the Coronavirus State and Local Fiscal Recovery Fund was \$19.8 million;

Whereas, on April 1, 2022, the U.S. Department of Treasury released the Final Rule covering the Coronavirus State and Local Fiscal Recovery Fund, as created and directed by the American Rescue Plan Act authorizing recipients to use funds to invest in public health improvements, economic recovery and development, services to disproportionately affected communities, and general government services, among other allowable purposes; and,

Whereas, the Board of Commissioners desires to make improvements and financial investments in several Township projects and initiatives in accordance with the allowable spending structure as described by the U.S. Department of Treasury's Final Rule, as follows:

One (1) 2024 F600 Chassis 4x4 SD Regular Cab 145" WB DRW XL (F6L) in an amount not to exceed \$63,335.00 under CoStars Contract #025-E22-381
Fred Beans Ford of Mechanicsburg 6320 Carlisle Pike Mechanicsburg, Pennsylvania 17050

For Chassis listed above:

One (1) Multi-Lift XR5S-3050 Hook Lift 12,000 Capacity

One (1) 10' Stainless Steel Dump Body

One (1) 20 Gallon Stainless Steel Valve/Tank Combo

One (1) Stainless Steel Salt Spreader with Poly Spinner

in an amount not to exceed \$89,500.00 under CoStars Contract #025-E22-432

Stephenson Equipment, INC. 4210 Chambers Hill Rd. Harrisburg, PA 17111

One (1) 11' Steel Flat Bed with Side Pockets Mounted in an amount not to exceed \$18,500.00 under CoStars Contract #025-E22-432
Stephenson Equipment, INC. 4210 Chambers Hill Rd. Harrisburg, PA 17111

One (1) Western 9' Pro Plus Snow Plow in an amount not to exceed \$8,000.00 under CoStars Contract# 025-E22-432
Stephenson Equipment, INC. 4210 Chambers Hill Rd. Harrisburg, PA 17111

One (1) 2-Ton Falcon Asphalt Recycler & Hot Box Hook Lift in an amount not to exceed \$40,911.20 under CoStars Contract# 025-E22-432
Stephenson Equipment, INC. 4210 Chambers Hill Rd. Harrisburg, PA 17111

One (1) 2024 Caterpillar 938 Front End Loader in an amount not to exceed \$281,165.00 under CoStars Contract #4400011420 Folly Cat INC. 855 Centennial Ave. Piscataway, NJ 08855

One (1) 2024 Broom Bear Sweeper on International Cab and Chassis in an amount not to exceed \$407,000.00 under CoStars Contract #025-E22-471 GranTurk Equipment Co., INC. 1 Schuylkill Parkway, Bldg. B, Bridgeport, PA 19405

One (1) 2024 Brush Bandit 18 Inch Tipper with Winch in an amount not to exceed \$98,715.00
under CoStars Contract #4400028339 SEI
Stephenson Equipment, INC. 4210 Chambers Hill Rd. Harrisburg, PA 17111

Three (3) SaltDogg Pro1500 Electric Poly Hopper Spreaders with Auger in an amount not to
exceed \$14,000.00 under CoStars Contract #4400028339
SEI Stephenson Equipment, INC. 4210 Chambers Hill Rd. Harrisburg, PA 17111

For a total fund obligation of \$1,008,937.00

Now, Therefore, be it Resolved, that the Board of Commissioners of Haverford Township
hereby approves the use of funds from the Township's American Rescue Plan Fund allocation
for the above referenced projects and initiatives.

Resolved this 12th day of February, 2024.

Township of Haverford

By:

C. Lawrence Holmes, Esq.

President

Attest:

David R. Burman

Township Manager/Secretary

Township of Haverford - Resolution No. 2366-2024

Whereas, the Township of Haverford is considering amendments to the General Laws of the Township of Haverford by amending Chapter 47 entitled "Amusement Devices" to further regulate the premises within which such devices may be permitted and associated definitions; amending Chapter 182 entitled "Zoning" to clarify the definition of Convenience Store, to define E-Liquids, Electronic Cigarettes, Electronic Nicotine Delivery Systems, Game of Skill Machines, Hookah Bars, Indoor Recreational or Amusement Facilities, Mechanical Amusement Devices, Significant Tobacco Retailers and Smoke Shops; to prohibit Mechanical Amusement Devices within the premises of Significant Tobacco Retailers and to prohibit Game of Skill Machines in Convenience Stores; to expressly prohibit Significant Tobacco Retailers in the C-2 Neighborhood Commercial District; to delete cigarette and tobacco as permitted to be sold in gift shops in the C-3 General Commercial District; to establish Significant Tobacco Retailers including Smoke Shops, Vape Shops and Hookah Lounges as a use permitted by Conditional Use in the C-5 Shopping Center Commercial District; and to establish the criteria for the approval of a Significant Tobacco Retailers use; and

Whereas, the Township desires to keep citizens and business interests informed as to the status of the proposed amendments.

Now, therefore it Resolved by the Board of Commissioners of the Township of Haverford, County of Delaware, Commonwealth of Pennsylvania that a public hearing shall be held before the Board of Commissioners on Monday, March 4, 2024 at 6:30 PM, in the Commissioners Meeting Room, Municipal Services Building, 1014 Darby Road, Havertown, Pennsylvania.

Resolved this 12th day of February, 2024.

Township of Haverford

By:
C. Lawrence Holmes, Esq.
President

Attest: David R. Burman
Township Manager
Township Manager/Secretary

Township of Haverford Police Department

Memorandum

Date: January 24, 2024

To: David R. Burman, Township Manager

From: John Viola

Re: New Vehicles

Whitmoyer Auto Group 1001 East Main Street Mount Joy, PA 17552
meets the requirements under COSTARS Contract #013-E22-264
for the purchase of the following Police vehicles:

Three, 2024 Chevrolet Tahoe Police vehicles CK10706
\$159,000

Two, 2024 Chevrolet Blazer Police vehicles, electric 1MF26
\$119,800

Total - \$278,800

Township of Haverford Police Department

Memorandum

Date: January 24, 2024

To: David R. Burman, Township Manager

From: John Viola

Re: New Vehicle

One (1) 2024 Landmaster AMP crew 4x4 electric ATV with a purchase price in the amount of \$22,800.01 from Wide World West Chester LLC 315, Westtown Road, West Chester PA 19382.

Township of Haverford - Public Works Department

Memorandum

Date: January 29, 2024

To: David R. Burman, Township Manager

From: Daniel Mariani, Director of Public Works

Re: Public Works Department Purchases

Description:

It is my recommendation that the Township enter into purchase agreements for the following pieces of heavy equipment in addition to specialty materials needed for the construction of a pole barn to provide additional storage at the public works yard. The funding for these purchases will come from the General Operating and Capital Project Budgets.

2024 F350 Regular Cab with 9ft Western Pro Plus Plow in the amount of \$66,110.00 under CoStars Contract #025-E22-387 from Hondru Ford, Manheim, PA

2024 F350 Super Cab with 9ft Western Pro Plus Plow in the amount of \$70,060.00 under CoStars Contract #025-E22-387 from Hondru Ford, Manheim, PA

2024 Altec 75ft Tree Bucket Truck with International Cab & Chassis in the amount of \$299,000.00 under CoStars Contract #4400019945 from Altec, Inc, Plains, PA

2024 HV607 International Cab & Chassis for Recycling Truck in the amount of \$128,164.40 under CoStars Contract #025-E22-471 from GranTurk Equipment Co. Inc, Bridgeport, PA

2024 20 yard Recycling Body for Cab & Chassis noted above in the amount of \$108,373.00 under CoStars Contract #025-E23-577 from Ascendence Trucks, Swedesboro, NJ

(1) Pole Barn with Concrete Pad in the amount of \$50,000.00 CoStars Contract #008-E23-1096 from Shirk Pole Buildings LLC, East Earl, PA

Township of Haverford - Public Works Department

Memorandum

Date: January 29, 2024

To: David R. Burman, Township Manager

From: Daniel Mariani, Director of Public Works

Re: Public Works Department Purchases

Description:

It is my recommendation that the Township enter into purchase agreements for the following vehicles and pieces of heavy equipment. The funding for these purchases will come from the Township's American Rescue Plan Fund.

One (1) 2024 F600 Chassis 4x4 SD Regular Cab 145" WB DRW XL (F6L in an amount not to exceed \$63,335.00 CoStars Contract #025-E22-381 Fred Beans Ford of Mechanicsburg 6320 Carlisle Pike Mechanicsburg, Pennsylvania 17050

One (1) Multi-Lift XR5S-3050 Hook Lift 12,000 Capacity
One (1) 10' Stainless Steel Dump Body
One (1) 20 Gallon Stainless Steel Valve/Tank Combo
One (1) Stainless Steel Salt Spreader with Poly Spinner in an amount not to exceed \$89,500.00 CoStars Contract #025-E22-432 Stephenson Equipment, INC. 4210 Chambers Hill Rd. Harrisburg, PA 17111

One (1) 11' Steel Flat Bed with Side Pockets Mounted in an amount not to exceed \$18,500.00 CoStars Contract #025-E22-432 Stephenson Equipment, INC. 4210 Chambers Hill Rd. Harrisburg, PA 17111

One (1) Western 9' Pro Plus Snow Plow in an amount not to exceed \$8,000.00 CoStars Contract #025-E22-432 Stephenson Equipment, INC. 4210 Chambers Hill Rd. Harrisburg, PA 17111

One (1) 2-Ton Falcon Asphalt Recycler & Hot Box Hook Lift in an amount not to exceed \$40,911.20 CoStars Contract#025-E22-432 Stephenson Equipment, INC. 4210 Chambers Hill Rd. Harrisburg, PA 17111

One (1) 2024 Caterpillar 938 Front End Loader in an amount not to exceed \$281,165.00 CoStars Contract #4400011420 Folly Cat INC. 855 Centennial Ave. Piscataway, NJ 08855

One (1) 2024 Broom Bear Sweeper on International Cab and Chassis in an amount not to exceed \$407,000.00 COSTAR #025-E22-471 GranTurk Equipment Co., INC. 1 Schuylkill Parkway, Bldg. B, Bridgeport, PA 19405

Township of Haverford - Public Works Department

Memorandum

Date: January 29, 2024

To: David R. Burman, Township Manager

From: Daniel Mariani, Director of Public Works

Re: Public Works Department Purchases

One (1) 2024 Brush Bandit 18 Inch Tipper with Winch in an amount not to exceed \$98,715.00
CoStars Contract # 025-E22-432 Stephenson Equipment, INC. 4210 Chambers Hill Rd.
Harrisburg, PA 17111

Three (3) SaltDogg Pro1500 Electric Poly Hopper Spreaders with Auger in an amount not
to exceed \$14,000.00 CoStars #025-E22-432 SEI Stephenson Equipment, INC. 4210
Chambers Hill Rd. Harrisburg, PA 17111

For a total fund obligation of \$1,008,937.00