

Haverford Township - Board of Commissioners

Meeting: Monday, February 12, 2024

Time: 7:00 p.m.

Location: Commissioners Meeting Room -1014 Darby Rd., Havertown PA, 19083

Regular Meeting Agenda

1. Opening of Meeting

Roll Call

Pledge of Allegiance

Announcement: The Board met in Executive Session prior to the Work Session last week to discuss Legal and Real Estate matters

2. Proclamations

Delaware County Chapter of the Pennsylvania Society of Professional Engineers 2024 Lifetime Achievement Award - Ed Magargee

Recognizing and Celebrating Black History Month

3. Citizens Forum – 20 Minutes – Registered Speakers – 20 Minutes – Agenda Items

4. Bureau of Fire Update

5. Township Auditor Update

6. Township Manager Update

7. Approval of Minutes

Motion: to approve the Reorganization Meeting Minutes of January 2, 2024 and the Regular Meeting Minutes of January 8, 2024.

8. Approval of Warrants

General Fund Disbursements in the amount of \$2,022,441.19

Sewer Fund Disbursements in the amount of \$214,974.93

Community Development Block Grant Fund Disbursements in the amount of \$44,344.81

Capital Projects Fund Disbursements in the amount of \$683,742.25

American Rescue Plan Fund in the amount of \$83,265.05

General & Sewer Fund Payroll for January 18, 2024 in the amount of \$921,992.76

General & Sewer Fund Payroll for February 1, 2024 in the amount of \$786,748.37

Credit Card Statement Ending January 27, 2024 in the amount of \$12,833.49

9. Appointment of Special Counsel

Motion to appoint Jennifer W. Brown, Esq. of Eastburn & Gray, PC, Blue Bell, PA to serve as Township Act 511 Special Counsel for any matters related to the enforcement and administration of business privilege, mercantile and local services tax at a rate of \$250 per hour; on an as needed basis.

10. Ordinance No. P1-2024

Amending Chapter 95 – Recycling (2nd Reading)

Motion: to adopt the second reading of Ordinance No. P1-2024 amending and supplementing the General Laws of the Township of Haverford Chapter 95, Article III Recycling, Sections 95-23 and 95-25 by adding a definition of Community Event and requiring organizers to provide separate containers for and to collect recyclable materials.

11. Ordinance No. P2-2024

Traffic (2nd Reading)

Motion: to adopt the second reading of Ordinance No. P2-2024 establishing/rescinding traffic restrictions on the following highways:

Parking Time Limited:

Establish: On the west side of Allston Road from Brookline Boulevard to, but not including 1204 Allston Road, 15-minute parking from 8:00 a.m. to 4:00 p.m., Monday through Friday

Rescind: Parking of All Vehicles Prohibited at All Times:

East side of Allston Road from Brookline Boulevard to Sagamore

West side of Allston Road from Brookline Boulevard to a point 35 feet south thereof

Rescind: Special Purpose Parking Zones:

On the West side of Allston Road, approximately 75 feet south of its intersection with Brookline Boulevard

12. Ordinance No. P3-2024

Skatium – Café Lease Renewal (1st Reading)

Motion: to adopt the first reading of Ordinance P3-2024 authorizing a renewal lease agreement with Shef & Sons, LLC dba Hav-A-Burger, Essington, PA for a portion of certain property located at 1018 Darby Road (the Skatium), Havertown, PA subject to review by the Township Solicitor and further subject to the approval of the Township Manager of the final document.

13. Ordinance No. P4-2024
Traffic (1st Reading)

Motion: to adopt the first reading of Ordinance No. P4-2024 authorizing traffic restrictions on the following highways:

Establish: Special Purpose Parking Zones: In front of 2447 Wynnefield Drive

Establish: Parking of All Vehicles Prohibited at All Times: No Parking Here to Corner - the unit block of Colfax Road, north side, from the corner of Darby Road to a point 60 feet west.

Rescind: Permit Parking Only on Mifflin Avenue

14. Resolution No. 2360-2024
Subdivision/Land Development – 14 Claremont Blvd.

Motion: to adopt Resolution No. 2360-2024 approving the recommendations and findings of the Planning Commission are hereby adopted and the Preliminary / Final / Land Development Plan for Caramanico Homes, LLC, 14 Claremont Blvd., Haverford Township, Delaware County, dated November 30, 2023, is approved subject to compliance with the recommendations described hereinabove.

15. Resolution No. 2362-2024
Use of ARPA Funds - Police Department

Motion: to adopt Resolution No. 2362-2024 approving the use of funds from the Township's American Rescue Plan Fund allocation for the purchase of one (1) 2024 Landmaster AMP crew 4 x 4 electric ATV for a total of \$22,800.01.

16. Resolution No. 2363-2024
Grant Application - Library Construction

Motion: to adopt Resolution No. 2363-2024 approving that the Board of Commissioners of the Township of Haverford of Delaware County hereby acknowledges its support for an application to the Commonwealth of Pennsylvania, Department of Community and Economic Development, COVID-19 ARPA Capital Projects Fund Multi-Purpose Community Facilities Program in the amount of \$268,750 to assist with the construction and technology outfitting of the Maker's Space/Innovation Zone to be located within the newly renovated Haverford Township Free Library and that the Applicant does hereby designate David R. Burman, Township Manager and Aimee M Cuthbertson, Assistant Township Manager as the officials to execute all documents and agreements between the Township of Haverford and the Department of Community and Economic Development to facilitate and assist in obtaining the requested grant.

17. Resolution No. 2364-2024
Grant Application - Skatium Locker Rooms

Motion: to adopt Resolution No. 2364-2024 approving that the Board of Commissioners of the Township of Haverford of Delaware County hereby acknowledges its support for an application to the Commonwealth of Pennsylvania, Department of Community and Economic Development, COVID-019 ARPA Capital Projects Fund Multi-Purpose Community Facilities Program in the amount of \$500,000 to assist with the space planning, construction and renovation of the locker rooms and related space at the Haverford Township Skatium; and, designating David R. Burman, Township Manager and Aimee M Cuthbertson, Assistant Township Manager as the officials to execute all documents and agreements between the Township of Haverford and the Department of Community and Economic Development to facilitate and assist in obtaining the requested grant.

18. Resolution No. 2365-2024
Use of ARPA Funds – Public Works Heavy Equipment

Motion: to adopt Resolution No. 2365-2024 that the Board of Commissioners of the Township of Haverford desires to make improvements and financial investments in several Township projects and initiatives in accordance with the allowable spending structure as described by the U.S. Department of Treasury's Final Rule, as follows:

One (1) 2024 F600 Chassis 4x4 SD Regular Cab 145" WB DRW XL (F6L) in an amount not to exceed \$63,335.00 under CoStars Contract #025-E22-381 Fred Beans Ford of Mechanicsburg 6320 Carlisle Pike Mechanicsburg, Pennsylvania 17050

For Chassis listed above:

One (1) Multi-Lift XR5S-3050 Hook Lift 12,000 Capacity

One (1) 10' Stainless Steel Dump Body

One (1) 20 Gallon Stainless Steel Valve/Tank Combo

One (1) Stainless Steel Salt Spreader with Poly Spinner

in an amount not to exceed \$89,500.00 under CoStars Contract #025-E22-432 Stephenson Equipment, INC. 4210 Chambers Hill Rd. Harrisburg, PA 17111

One (1) 11' Steel Flat Bed with Side Pockets Mounted in an amount not to exceed \$18,500.00 under CoStars Contract #025-E22-432 Stephenson Equipment, INC. 4210 Chambers Hill Rd. Harrisburg, PA 17111

One (1) Western 9' Pro Plus Snow Plow in an amount not to exceed \$8,000.00 under CoStars Contract# 025-E22-432 Stephenson Equipment, INC. 4210 Chambers Hill Rd. Harrisburg, PA 17111

One (1) 2-Ton Falcon Asphalt Recycler & Hot Box Hook Lift in an amount not to exceed \$40,911.20 under CoStars Contract# 025-E22-432 Stephenson Equipment, INC. 4210 Chambers Hill Rd. Harrisburg, PA 17111

One (1) 2024 Caterpillar 938 Front End Loader in an amount not to exceed \$281,165.00 under CoStars Contract #4400011420 Folly Cat INC. 855 Centennial Ave. Piscataway, NJ 08855

One (1) 2024 Broom Bear Sweeper on International Cab and Chassis in an amount not to exceed \$407,000.00 under CoStars Contract #025-E22-471 GranTurk Equipment Co., INC. 1

One (1) 2024 Brush Bandit 18 Inch Chipper with Winch in an amount not to exceed \$98,715.00 under CoStars Contract #4400028339 SEI Stephenson Equipment, INC. 4210 Chambers Hill Rd. Harrisburg, PA 17111

Three (3) SaltDogg Pro1500 Electric Poly Hopper Spreaders with Auger in an amount not to exceed \$14,000.00 under CoStars Contract #4400028339 SEI Stephenson Equipment, INC. 4210 Chambers Hill Rd. Harrisburg, PA 17111

19. Resolution No. 2366-2024
Announcement of Public Hearing- Zoning – Amending Chapter 47 entitled Amusement Devices

Motion: to adopt Resolution No. 2366-2024 amending Chapter 47 entitled Amusement Devices Holding a Public Hearing on March 4, 2024 at 6:30 p.m. in the Commissioners Meeting Room, 1014 Darby Road, Havertown, PA.

20. Resolution No. 2367-2024
Preliminary/Final Plan – 2224-2228 Haverford Road

Motion: to consider Resolution No. 2367-2024.

21. Approval:

Motion: to approve Chief of Police contract extension retroactively from 1/4/2024 to 1/4/2026.

Motion: to approve the Park, Recreation & Open Space Plan

22. Purchases:

Police Department

Motion: to authorize the purchase of three (3) 2024 Chevrolet Tahoe Police Vehicles and two (2) 2024 Electric Chevrolet Blazer Police Vehicles 1MF26, under CoStars Contract #013-E22-264, from Whitmoyer Auto Group, 1001 East Main Street, Mount Joy, PA, in the amount of \$278,800.

Motion: to authorize the purchase of one (1) 2024 Landmaster AMP Crew 4 x 4 from Wide World West Chester, PA in the amount of \$22,800.01

Public Works Department from the General Operating and Capital Project Budgets

Motion to authorize the purchase of:

2024 Ford F350 Regular Cab with 9ft Western Pro Plus Plow in the amount of \$66,110.00 under CoStars Contract #025-E22-387 from Hondru Ford, Manheim, PA

2024 Ford F350 Super Cab with 9ft Western Pro Plus Plow in the amount of \$70,060.00 under CoStars Contract #025-E22-387 from Hondru Ford, Manheim, PA

2024 Altec 75ft Tree Bucket Truck with International Cab & Chassis in the amount of \$299,000.00 under CoStars Contract #4400019945 from Altec, Inc, Plains, PA

2024 International Cab & Chassis HV607 for Recycling Truck in the amount of \$128,164.40 under CoStars Contract #025-E22-471 from GranTurk Equipment Co. Inc, Bridgeport, PA

2024 Recycling Body (20-yard) for Cab & Chassis noted above in the amount of \$108,373.00 under CoStars Contract #025-E23-577 from Ascendence Trucks, Swedesboro, NJ

Pole Barn (1) with Concrete Pad in the amount of \$50,000.00 CoStars Contract #008-E23-1096 from Shirk Pole Buildings LLC, East Earl, PA

Public Works Department from ARPA Funds

Motion to authorize the purchase of:

One (1) 2024 F600 Chassis 4x4 SD Regular Cab 145" WB DRW XL (F6L) in an amount not to exceed \$63,335.00 under CoStars Contract #025-E22-381 from Fred Beans Ford of Mechanicsburg 6320 Carlisle Pike Mechanicsburg, Pennsylvania 17050

For Chassis listed above:

One (1) Multi-Lift XR5S-3050 Hook Lift 12,000 Capacity

One (1) 10' Stainless Steel Dump Body

One (1) 20 Gallon Stainless Steel Valve/Tank Combo

One (1) Stainless Steel Salt Spreader with Poly Spinner

in an amount not to exceed \$89,500.00 under CoStars Contract #025-E22-432 from Stephenson Equipment, INC. 4210 Chambers Hill Rd. Harrisburg, PA 17111

One (1) 11' Steel Flat Bed with Side Pockets Mounted in an amount not to exceed \$18,500.00 under CoStars Contract #025-E22-432 from Stephenson Equipment, INC. 4210 Chambers Hill Rd. Harrisburg, PA 17111

One (1) Western 9' Pro Plus Snow Plow in an amount not to exceed \$8,000.00 under CoStars Contract# 025-E22-432 from Stephenson Equipment, INC. 4210 Chambers Hill Rd. Harrisburg, PA 17111

One (1) 2-Ton Falcon Asphalt Recycler & Hot Box Hook Lift in an amount not to exceed \$40,911.20 under CoStars Contract# 025-E22-432 Stephenson Equipment, INC. 4210 Chambers Hill Rd. Harrisburg, PA 17111

One (1) 2024 Caterpillar 938 Front End Loader in an amount not to exceed \$281,165.00 under CoStars Contract #4400011420 from Folly Cat INC. 855 Centennial Ave. Piscataway, NJ 08855

One (1) 2024 Broom Bear Sweeper on International Cab and Chassis in an amount not to exceed \$407,000.00 under CoStars Contract #025-E22-471 from GranTurk Equipment Co., INC. 1 Schuylkill Parkway, Bldg. B, Bridgeport, PA 19405

23. Appointments:

Representative to Bryn Mawr Playfield Association - Motion: to appoint (*space for name to be filled in after voting is completed*) to the Bryn Mawr Playfield Association.

Civil Service Commission - Alternate - Motion: to appoint (*space for name to be filled in after voting is completed*) to fill an unexpired six (6) year term to expire December 31, 2028.

Friends of the Grange - Motion: to appoint (*space for name to be filled in after voting is completed*) to fill an unexpired two (2) year term to expire December 31, 2024.

Senior Citizen Advisory Board - 6th Ward Only

Vacancy Committee - Motion: to appoint (*space for name to be filled in after voting is completed*) to serve on the Vacancy Committee for a one-year term to expire December 31, 2024.

Vacant Property Review Committee - Motion: to appoint (*space for name to be filled in after voting is completed*) to serve on the Vacant Property Review Committee for a five-year term to expire December 31, 2028.

24. Continuation of Citizen's Forum for Non-Agenda Items

25. New business

26. Other business

27. Adjourn

Haverford Township – Board of Commissioners Reorganization

Meeting: Monday, January 2, 2024

Time: 7:30 P.M.

Location: Commissioners Meeting Room – 1014 Darby Road, Havertown, PA 19083

Opening of Meeting - David R. Burman, Township Manager, opened the meeting.

Roll Call – All 9 Commissioners and Commissioner-elects were present: Commissioner Gondek, Forste-Grupp, McCloskey, Trombetta, Cavender, Holmes, Quinn, Hart and McCollum.

Also present were: Kailie Melchior, Esq., Township Solicitor, Chief John Viola, Deputy Chief Joe Hagan and Paramedic Chief Jim McCans

Pledge of Allegiance

Invited Guest: The Honorable Elysia Mancini Duerr, Esq.

Oath of Office

Commissioner Elect Brian Gondek, Esq.

Commissioner Elect Kevin McCloskey, Esq.

Commissioner Elect Laura Cavender

Commissioner Elect Conor Quinn

Commissioner Elect Michael McCollum

Nominations – President of the Board of Commissioners

Motion made by Commissioner Forste-Grupp and seconded by Commissioner Conor Quinn to nominate Commissioner Larry Holmes as President of the Board of Commissioners.

Motion to close made by Commissioner Forste-Grupp and seconded by Commissioner Quinn.

All 9 Commissioners voted Yes: Commissioner Gondek, Forste-Grupp, McCloskey, Trombetta, Cavender, Holmes, Quinn, Hart and McCollum.

Nominations – Vice President of the Board of Commissioners

Motion made by Commissioner Forste-Grupp and seconded by Commissioner Cavender to nominate Commissioner Judy Trombetta as Vice President of the Board of Commissioners.

Motion to close made by Commissioner Gondek and seconded by Cavender.

All 9 Commissioners voted Yes: Commissioner Gondek, Forste-Grupp, McCloskey, Trombetta, Cavender, Holmes, Quinn, Hart and McCollum.

Appointments – Administrative

Township Solicitor

Motion made by Commissioner Cavender and seconded by Commissioner Forste-Grupp to reappoint John Walko, Esq., as Township Solicitor for a one-year term to expire December 31, 2024.

Motion to close made by Commissioner Gondek and seconded by Commissioner Quinn.

All 9 Commissioners voted Yes: Commissioner Gondek, Forste-Grupp, McCloskey, Trombetta, Cavender, Holmes, Quinn, Hart and McCollum.

Township Engineer

Motion made by Commissioner Quinn and seconded by Commissioner Forste-Grupp to confirm the Township Manager's appointment of Pennoni Associates as Township Engineer for a one-year term to expire December 31, 2024.

All 9 Commissioners voted Yes: Commissioner Gondek, Forste-Grupp, McCloskey, Trombetta, Cavender, Holmes, Quinn, Hart and McCollum.

Resolution No. 2352 - 2024

Appointments – Boards and Commissions

Motion made by Commissioner McCloskey and seconded by Commissioner Forste-Grupp to adopt Resolution No. 2352 - 2024 appointing the following Boards and Commissions.

All 9 Commissioners voted Yes: Commissioner Gondek, Forste-Grupp, McCloskey, Trombetta, Cavender, Holmes, Quinn, Hart and McCollum.

Zoning Hearing Board – 5 Year Term

Motion made by Commissioner Cavender and seconded by Commissioner Forste-Grupp to appoint Julia Krasniqi to serve on the Zoning Hearing Board for a five-year term to expire on December 31, 2028.

Motion made by Commissioner Hart and seconded by Commissioner Quinn to reappoint Jessica Vitali to serve on the Zoning Hearing Board for a five-year term to expire on December 31, 2028.

Motion to close made by Commissioner Quinn and seconded by Commissioner Forste-Grupp.

7 Commissioners voted for Jessica Vitali: Commissioners Gondek, McCloskey, Quinn, Hart, McCollum, Trombetta and Holmes.

2 Commissioners voted for Julia Krasniqi: Commissioner Forste-Grupp and Cavender

Vacancy Committee – 1 Year Term

Motion made by Commissioner Gondek and seconded by Commissioner Quinn to TABLE the Vacancy Committee for a one-year term to expire December 31, 2024.

All 9 Commissioners voted Yes to TABLE: Commissioner Gondek, Forste-Grupp, McCloskey, Trombetta, Cavender, Holmes, Quinn, Hart and McCollum.

Vacant Property Review Committee – 5 Year Term

Motion made by Commissioner Gondek and seconded by Commissioner Quinn to TABLE the Vacant Property Review Committee for a five-year term to expire December 31, 2028.

All 9 Commissioners voted Yes to TABLE: Commissioner Gondek, Forste-Grupp, McCloskey, Trombetta, Cavender, Holmes, Quinn, Hart and McCollum.

RHM – 5 Year Term

Motion made by Commissioner Hart and seconded by Commissioner Trombetta to reappoint Michael Stevens to serve on the RHM Sewer Authority for a five-year term to expire December 31, 2028.

Motion to close made by Commissioner Gondek. Seconded could not be made out clearly.

All 9 Commissioners voted Yes: Commissioner Gondek, Forste-Grupp, McCloskey, Trombetta, Cavender, Holmes, Quinn, Hart and McCollum.

Shade Tree Commission – 3 Year Term

Motion made by Commissioner Hart and seconded by Commissioner Forste-Grupp to appoint Edmond Krasniqi to serve on the Shade Tree Commission for a three-year term to expire December 31, 2026.

Motion to close made by Commissioner Trombetta and seconded by Commissioner Quinn.

All 9 Commissioners voted Yes: Commissioner Gondek, Forste-Grupp, McCloskey, Trombetta, Cavender, Holmes, Quinn, Hart and McCollum.

Motion made by Commissioner Hart and seconded by Commissioner McCloskey to reappoint James Stephens to serve on the Shade Tree Commission for a three-year term to expire December 31, 2026.

Motion to close made by Commissioner Hart and seconded by Commissioner McCloskey.

All 9 Commissioners voted Yes: Commissioner Gondek, Forste-Grupp, McCloskey, Trombetta, Cavender, Holmes, Quinn, Hart and McCollum.

Motion made by Commissioner Hart and seconded by Commissioner Cavender to reappoint Pano Kalogeropoulos to serve on the Shade Tree Commission for a three-year term to expire December 31, 2026.

Motion to close made by Commissioner Hart and seconded by Commissioner Cavender.

All 9 Commissioners voted Yes: Commissioner Gondek, Forste-Grupp, McCloskey, Trombetta, Cavender, Holmes, Quinn, Hart and McCollum.

Planning Commission – 4 Year Term

Motion made by Commissioner Cavender and seconded by Commissioner Trombetta to reappoint Maggie Dobbs to serve on the Planning Commission for a four-year term to expire on December 31, 2027.

Motion to close made by Commissioner Quinn and seconded by Commissioner Hart.

All 9 Commissioners voted Yes: Commissioner Gondek, Forste-Grupp, McCloskey, Trombetta, Cavender, Holmes, Quinn, Hart and McCollum.

Motion made by Commissioner McCloskey and seconded by Commissioner Trombetta to appoint Stephen Welsh to serve on the Planning Commission for a four-year term to expire on December 31, 2027.

Motion made by Commissioner Quinn and seconded by Commissioner Hart to reappoint Jack Garrett.

Motion to close made by Commissioner McCloskey and seconded by Commissioner Trombetta.

6 Commissioners voted for Stephen Welsh: Commissioners Gondek, Forste-Grupp, McCloskey, Cavender, Trombetta and Holmes.

3 Commissioners voted for Jack Garrett: Commissioners Quinn, Hart and McCollum.

Parks and Recreation Board – 5 Year Term

Motion made by Commissioner Quinn and seconded by Commissioner Gondek to appoint Jay Field to serve on the Parks and Recreation Board for a five-year term to expire on December 31, 2028.

Motion made by Commissioner Trombetta and seconded by Commissioner Forste-Grupp to appoint Steve Young to serve on the Parks and Recreation Board for a five-year term to expire on December 31, 2028.

Motion to close made by Commissioner Gondek and seconded by Commissioner Quinn.

6 Commissioners voted for Steve Young: Commissioners Forste-Grupp, McCloskey, Cavender, Hart, Trombetta and Holmes.

3 Commissioners voted for Jay Field: Commissioners Gondek, Quinn and McCollum.

Ice Rink Advisory Board – 3 Year Term

Motion made by Commissioner Gondek and seconded by Commissioner Trombetta to reappoint Jeremy Beha to serve on the Ice Rink Advisory Board for a three-year term to expire December 31, 2026.

Motion to close made by Commissioner Trombetta and seconded by Commissioner Gondek.

All 9 Commissioners voted Yes: Commissioner Gondek, Forste-Grupp, McCloskey, Trombetta, Cavender, Holmes, Quinn, Hart and McCollum.

Motion made by Commissioner Gondek and seconded by Commissioner Trombetta to reappoint Jason Brinn to serve on the Ice Rink Advisory Board for a three-year term to expire December 31, 2026.

Motion to close made by Commissioner Gondek and seconded by Commissioner Trombetta.

All 9 Commissioners voted Yes: Commissioner Gondek, Forste-Grupp, McCloskey, Trombetta, Cavender, Holmes, Quinn, Hart and McCollum.

Motion made by Commissioner Gondek and seconded by Commissioner Trombetta to appoint Adam Hayes to serve on the Ice Rink Advisory Board for a three-year term to expire December 31, 2026.

Motion to close made by Commissioner Trombetta and seconded by Commissioner Hart.

All 9 Commissioners voted Yes: Commissioner Gondek, Forste-Grupp, McCloskey, Trombetta, Cavender, Holmes, Quinn, Hart and McCollum.

Human Relations Commission – 3 Year Term

Motion made by Commissioner Cavender and seconded by Commissioner Trombetta to reappoint Jen Kererise to serve on the Human Relations Commission for a three-year term to expire December 31, 2026.

Motion made by Commissioner Quinn and seconded by Commissioner Gondek to appoint Melissa Haub.

Motion to close made by Commissioner Gondek and seconded by Commissioner Cavender to close.

6 Commissioners voted for Jen Kererise: Commissioners Gondek, McCloskey, Cavender, Hart, Trombetta and Holmes.

3 Commissioners voted for Melissa Haub: Commissioners Gondek, Quinn and McCollum.

Motion made by Commissioner Hart and seconded by Commissioner Trombetta to reappoint Andrew LeDonne to serve on the Human Relations Commission for a three-year term to expire December 31, 2026.

Motion made by Commissioner McCollum and seconded by Commissioner Quinn to appoint Kay Dugery.

Motion made by Commissioner McCollum and seconded by Commissioner Cavender to close.

6 Commissioners voted for Andrew LeDonne: Commissioners Forste-Grupp, McCloskey, Cavender, Hart, Trombetta and Holmes.

3 Commissioners voted for Kay Dugery: Commissioners Gondek, Quinn and McCollum.

Historical Commission - 4 Year term

Motion made by Commissioner Cavender and seconded by Commissioner Trombetta to reappoint Keith Swift to serve on the Historical Commission for a four-year term to expire on December 31, 2027.

Motion made by Commissioner Forste-Grupp and seconded by Commissioner Quinn to reappoint Bryan Ramona.

Motion to close made by Commissioner Trombetta and seconded by Commissioner Quinn.

6 Commissioners voted for Keith Swift: Commissioners Gondek, McCloskey, Trombetta, Hart, Trombetta and Holmes.

3 Commissioners voted for Bryan Ramona: Commissioners Forste-Grupp, Quinn and McCollum.

Motion made by Commissioner Forste-Grupp and seconded by Commissioner Quinn to reappoint Bryan Ramona to serve on the Historical Commission for a four-year term to expire on December 31, 2027.

Motion made by Commissioner McCloskey and seconded by Commissioner Hart to appoint Anthony Morinelli.

Motion to close made by Quinn and seconded by Commissioner McCloskey.

6 Commissioners voted for Bryan Ramona: Commissioner Gondek, McCloskey, Trombetta, Quinn, McCollum and Trombetta.

3 Commissioners voted for Anthony Morinelli: Commissioner Forste-Grupp, Hart and Holmes.

Health Advisory Board – 5 Year Term

Motion made by Commissioner McCloskey and seconded by Commissioner Trombetta to appoint Katie Mechler to serve on the Health Advisory Board for a five-year term to expire on December 31, 2028.

Motion to close made by Commissioner Gondek and seconded by Commissioner Trombetta.

All 9 Commissioners voted Yes: Commissioner Gondek, Forste-Grupp, McCloskey, Trombetta, Cavender, Holmes, Quinn, Hart and McCollum.

Civil Service Commission – 6 Year Term

Motion made by Commissioner Forste-Grupp and seconded by Commissioner Cavender to appoint Maher Zamel to serve on the Civil Service Commission for a 6-year term to expire December 31, 2029.

Motion made by Commissioner Gondek and seconded by Commissioner Quinn to TABLE the Civil Service Commission for a 6-year term to expire December 31, 2029.

7 Commissioners voted to TABLE: Commissioners Gondek, McCloskey, Quinn, Hart, McCollum, Trombetta and Holmes.

2 Commissioners voted No: Commissioners Forste-Grupp and Cavender.

Discussion began concerning the Grange Estate member's terms.

All Commissioners voted to adjourn.

Best Wishes For A Great New Year!

Haverford Township – Board of Commissioners

Meeting: MONDAY, JANUARY 8, 2024

Location: Commissioners Meeting Room – 1014 Darby Rd, Havertown, PA 19083

Regular Meeting Minutes

Opening of Meeting – Larry Holmes, President, opened the meeting.

Roll Call – All 9 Commissioners were present at roll call: Commissioners Gondek, Forste-Grupp, McCloskey, Cavender, Quinn, Hart, McCollum, Trombetta and Holmes.

Also present were: David R. Burman, Township Manager, John Walko, Esq., Township Solicitor, Chief John Viola, Brian Barrett, Parks and Recreation Director and Chuck Faulkner, Township Engineer.

Pledge of Allegiance

Citizens Forum – 20 Minutes Registered Speakers – Agenda Items Only

No one spoke during either portion.

Commissioner Committee Update

Commissioner Holmes provided the Bureau of Fire Report.

Police Department – Crime Update

Chief Viola presented his update for the month of December.

Township Auditor Update

Due to Mr. Anderson's absence, Commissioner Hart reported that Mr. Anderson reviewed the warrants and found no irregularities.

Township Manager Update

Mr. Burman provided an update on the Library's interior demolition and a change order for 1 Mill Road. He also provided an update on the Pennsy Trail Extension.

Approval of Minutes

Motion made by Commissioner Quinn and seconded by Commissioner Hart to approve the Budget/Regular Meeting Minutes of December 11, 2023.

All 9 Commissioners voted Yes: Commissioners Gondek, Forste-Grupp, McCloskey, Cavender, Quinn, Hart, McCollum, Trombetta and Holmes.

Approval of Warrants

Motion made by Commissioner McCloskey and seconded by Commissioner Trombetta to approve the following warrant #1-2024 totaling \$4,578,674.43

General & Sewer fund Payroll for December 21, 2023 in the amount of \$770,659.46

General & Sewer fund Payroll for January 4, 2024 in the amount of \$865,286.31

General Fund disbursements #1-2024 in the amount of \$816,642.06

Sewer Fund disbursements #1-2024 in the amount of \$273,095.02

Community Development Block Grant Fund disbursement #1-2024
in the amount of \$98,435.97

Capital Projects Fund disbursement #1-2024 in the amount of \$1,554,924.38

American Rescue Plan Fund disbursement #1-2024 in the amount of \$169,662.82

Credit Card Statement ending December 27, 2023, in the amount of \$29,968.41

All 9 Commissioners voted Yes: Commissioners Gondek, Forste-Grupp, McCloskey, Cavender, Quinn, Hart, McCollum, Trombetta and Holmes.

Tax Assessment Appeal Stipulation for Approval Consideration

Motion made by Commissioner McCloskey and seconded by Commissioner Trombetta to Approve the Settlement and Stipulation of Counsel in the matter of an owner initiated property tax assessment appeal for property located at 124 Harvard Road (D.C. Folio #22-07-00616-01) pending in the Court of Common Pleas of Delaware County No. 2023-003226 and authorize Counsel and proper officers of the Board to execute necessary documents.

All 8 Commissioners voted Yes: Commissioners Gondek, Forste-Grupp, McCloskey, Cavender, Quinn, McCollum, Trombetta and Holmes.

Commissioner Hart voted No.

Ordinance No. P19-2023
Traffic (2nd Reading)

Motion made by Commissioner Quinn and seconded by Commissioner Hart to adopt the second reading of Ordinance No. P19-2023 authorizing traffic restrictions on the following highways:

Special Purpose Parking Zones

Establish: in front of 1611 Woodmere Way.

All 9 Commissioners voted Yes: Commissioners Gondek, Forste-Grupp, McCloskey, Cavender, Quinn, Hart, McCollum, Trombetta and Holmes.

Ordinance No. P20-2023
Amending Chapter 165 – Taxation (2nd Reading)

Motion made by Commissioner Cavender and seconded by Commissioner Trombetta to adopt the second reading of Ordinance No. P20-2023 amending Ordinance No. 1960, adopted June 30, 1986, and known as the “general laws of the township of Haverford”, further amending Chapter 165, “Taxation”, Article VI, “Property Tax Credit to qualifying volunteers of Bon Air, Brookline, Llanerch, Manoa and Oakmont Fire Companies”.

All 9 Commissioners voted Yes: Commissioners Gondek, Forste-Grupp, McCloskey, Cavender, Quinn, Hart, McCollum, Trombetta and Holmes.

Ordinance No. P1-2024
Amending Chapter 95 – Recycling (1st Reading)

Motion made by Commissioner Cavender and seconded by Commissioner Trombetta to Adopt the first reading of Ordinance No. P1-2024 amending Chapter 95, Article III, Recycling, Section 95-13 by including collection of recyclables at all Haverford Township Community Events.

All 9 Commissioners voted Yes: Commissioners Gondek, Forste-Grupp, McCloskey, Cavender, Quinn, Hart, McCollum, Trombetta and Holmes.

Ordinance No. P2-2024
Traffic (1st Reading)

Motion made by Commissioner Quinn and seconded by Commissioner Trombetta to adopt the first reading of Ordinance No. P2-2024 establishing/rescinding traffic restrictions on the following highways:

Parking Time Limited: ESTABLISH:

On the west side of Allston Road from Brookline Boulevard to, but not including 1204 Allston Road, 15-minute parking from 8:00 a.m. to 4:00 p.m., Monday through Friday

Parking of All Vehicles Prohibited at All Times: RESCIND

East side of Allston Road from Brookline Boulevard to Sagamore

West side of Allston Road from Brookline Boulevard to a point 35 feet south thereof

Special Purpose Parking Zones: RESCIND

On the West side of Allston Road, approximately 75 feet south of its intersection with Brookline Boulevard

All 9 Commissioners voted Yes: Commissioners Gondek, Forste-Grupp, McCloskey, Cavender, Quinn, Hart, McCollum, Trombetta and Holmes.

Resolution No. 2353-2024

Document Destruction

Motion made by Commissioner McCloskey and seconded by Commissioner Trombetta to adopt Resolution No. 2353 – 2024 that the Board of Commissioners of the Township of Haverford, County of Delaware, Commonwealth of Pennsylvania, in accordance with the Municipal Records Manual hereby authorizes the disposition of public records.

All 9 Commissioners voted Yes: Commissioners Gondek, Forste-Grupp, McCloskey, Cavender, Quinn, Hart, McCollum, Trombetta and Holmes.

Resolution No. 2354 -2024

Annual Fee Schedule

Motion made by Commissioner McCloskey and seconded by Commissioner Gondek to adopt Resolution No. 2354-2024 approving the annual Fee Schedule for 2024.

All 9 Commissioners voted Yes: Commissioners Gondek, Forste-Grupp, McCloskey, Cavender, Quinn, Hart, McCollum, Trombetta and Holmes.

Resolution No. 2355-2024

Township Manager/Secretary Renewal Contract

Motion made by Commissioner Trombetta and seconded by Commissioner Quinn to reappoint David R. Burman to a two-year contract as Township Manager/Secretary commencing January 8, 2024 and ending on January 5, 2026.

All 9 Commissioners voted Yes: Commissioners Gondek, Forste-Grupp, McCloskey, Cavender, Quinn, Hart, McCollum, Trombetta and Holmes.

Resolution No. 2356-2024

4008 Darby Road Revision for New Land Development Sewer Extension

Motion made by Commissioner Trombetta and seconded by Commissioner Cavender to adopt Resolution No. 2356-2024 approving the 4008 Darby Road Revision for New Development Sewer Extension.

All 9 Commissioners voted Yes: Commissioners Gondek, Forste-Grupp, McCloskey, Cavender, Quinn, Hart, McCollum, Trombetta and Holmes.

Resolution No. 2357-2024

ARPA Funds – Playground Equipment

Motion made by Commissioner Hart and seconded by Commissioner Quinn to adopt Resolution No. 2357-2024 that the Board of Commissioners of Haverford Township hereby approves the use of \$50,000.00 of the Township's American Rescue Plan Fund allocation to replace two baseball cages at Grange Park.

All 9 Commissioners voted Yes: Commissioners Gondek, Forste-Grupp, McCloskey, Cavender, Quinn, Hart, McCollum, Trombetta and Holmes.

Resolution No. 2358-2024

Professional Consultant Fees

Motion made by Commissioner McCloskey and seconded by Commissioner Cavender to adopt Resolution No. 2358-2024 approving its 2024 fee schedule for Professional Consultants.

All 9 Commissioners voted Yes: Commissioners Gondek, Forste-Grupp, McCloskey, Cavender, Quinn, Hart, McCollum, Trombetta and Holmes.

Resolution No. 2359-2024

ARPA Funds – Playground Equipment

Motion made by Commissioner Hart and seconded by Commissioner McCollum to adopt Resolution No. 2359-2024 that the Board of Commissioners of Haverford Township hereby approves the use of \$24,116.00 of the Township's American Rescue Plan Fund allocation for the replacement of playground equipment at Hilltop Park.

All 9 Commissioners voted Yes: Commissioners Gondek, Forste-Grupp, McCloskey, Cavender, Quinn, Hart, McCollum, Trombetta and Holmes.

Change Orders

Township Library

Motion made by Commissioner Forste-Grupp and seconded by Commissioner Cavender to ratify Change Order No. 1 with Rycon Construction in an amount not to exceed \$22,500 for the proper removal and disposition of unforeseen asbestos materials in the Haverford Township Free Library.

All 9 Commissioners voted Yes: Commissioners Gondek, Forste-Grupp, McCloskey, Cavender, Quinn, Hart, McCollum, Trombetta and Holmes.

The Skatium

Motion made by Commissioner Gondek and seconded by Commissioner Trombetta to ratify Change Order No. 1 with McCloskey Mechanical Contractors, Inc in the amount of \$40,006.20 for proper replacement of the deteriorated steel dunnage which establishes the foundation for the cooling towers currently under construction on the roof of the Haverford Township Skatium.

All 9 Commissioners voted Yes: Commissioners Gondek, Forste-Grupp, McCloskey, Cavender, Quinn, Hart, McCollum, Trombetta and Holmes.

Agreement

Motion made by Commissioner Trombetta and seconded by Commissioner Cavender to approve Professional Service Agreement with Discover Haverford to administer the Business Revitalization & Modernization Matching Grant program.

All 9 Commissioners voted Yes: Commissioners Gondek, Forste-Grupp, McCloskey, Cavender, Quinn, Hart, McCollum, Trombetta and Holmes.

Contract Awards

Police/Municipal Mechanical/Energy – Preventive Maintenance Contract

Motion made by Commissioner Cavender and seconded by Commissioner Trombetta to approve a Police/Municipal Mechanical/Energy – Preventive Maintenance Contract with the Tustin Group, Norristown, PA, in the amount of Year 1: \$20,644.00 and Year 2: \$21,698.00.

All 9 Commissioners voted Yes: Commissioners Gondek, Forste-Grupp, McCloskey, Cavender, Quinn, Hart, McCollum, Trombetta and Holmes.

Skatium – Professional Services Contract

Motion made by Commissioner Gondek and seconded by Commissioner Cavender to enter into professional services contract with BKP Architects of Philadelphia, PA for architectural design services and preparation of construction documents related to the Haverford Township Skatium Locker Room Renovation and Space Planning Project in a cost not to exceed \$109,920.00

All 9 Commissioners voted Yes: Commissioners Gondek, Forste-Grupp, McCloskey, Cavender, Quinn, Hart, McCollum, Trombetta and Holmes.

Darby Creek Trail Extension – Phase 1

Motion made by Commissioner Hart and seconded by Commissioner McCollum to award the Darby Creek Trail, Southern Extension – Phase 1, to Premier Concrete, Inc., Broomall, PA, in the amount of \$125,975.00; contingent upon the execution of the contract and supply of the required bonds and insurance.

All 9 Commissioners voted Yes: Commissioners Gondek, Forste-Grupp, McCloskey, Cavender, Quinn, Hart, McCollum, Trombetta and Holmes.

Parks and Recreation

CREC – HVAC System

Motion made by Commissioner Hart and seconded by Commissioner Trombetta to approve a one year HVAC Maintenance Contract for the CREC with Trane Technologies, King of Prussia, PA, in the amount of \$18,841.29.

All 9 Commissioners voted Yes: Commissioners Gondek, Forste-Grupp, McCloskey, Cavender, Quinn, Hart, McCollum, Trombetta and Holmes.

Purchases

Playground Equipment

Grange Park

Motion made by Commissioner Hart and seconded by Commissioner Quinn to authorize the purchase of two (2) baseball cages and fencing at Grange Park from Miller Sports Construction, West Chester, PA, under Co-Stars Contract #: 008-E22-184, in the amount of \$50,000.00.

All 9 Commissioners voted Yes: Commissioners Gondek, Forste-Grupp, McCloskey, Cavender, Quinn, Hart, McCollum, Trombetta and Holmes.

Hilltop Park

Motion made by Commissioner McCollum and seconded by Commissioner Trombetta to authorize the purchase of a replacement play equipment structure, from Recreation Resource, Kennett Square, PA, under Co-Stars Contract #014-E22-249, in the amount of \$24,116.00.

All 9 Commissioners voted Yes: Commissioners Gondek, Forste-Grupp, McCloskey, Cavender, Quinn, Hart, McCollum, Trombetta and Holmes.

Appointment:

Civil Service Commission

Motion made by Commissioner Quinn and seconded by Commissioner McCollum to appoint Mark O'Connor to serve on the Civil Service Commission for a six (6) year term to expire December 31, 2029.

Motion made by Commissioner Hart and seconded by Commissioner McCloskey to appoint Monet Reilly.

Motion to close made by Commissioner Trombetta and seconded by Commissioner Quinn.

5 Commissioners voted for Mark O'Connor: Commissioners Gondek, Quinn, McCollum, Trombetta and Holmes.

4 Commissioners voted for Monet Reilly: Commissioners Forste-Grupp, McCloskey, Cavender and Hart.

Discussion began concerning the terms for the Grange members. He provided clarification – the board did make them 2 year terms. The Grange does not need to revise their by-laws.
Continuation of Citizen's Forum for Non-Agenda Items

Todd Hall – 2nd Ward Resident

Mr. Hall highlighted Kids Night Out held during the winter months at the CREC. He hopes it can continue during other seasons.

Victor Barsky – 5th Ward Resident

Mr. Barsky congratulated Mr. Burman on his reappointment.

New business

Both Commissioner Hart and Quinn reported to the Board the major tree issue at the Grange. A 300-year old tree uprooted. This will be an expensive undertaking to remove. Other historical trees may have to be removed.

Commissioner Gondek spoke on the increase of vape shops in residential and school areas within township and asked for guidance of township solicitor.

Other business

1st Ward Commissioner Brian Gondek

He wished everyone a safe, happy and healthy new year. He also stated that the County's Health Department mailed to 70% of the county, plastic bags to be used for drug disposal...just add water in the bag. (These non-toxic pouches are an organic and safe alternative for proper disposal of unused, unwanted and expired medications with the simple addition of water. In a simple 3-step process, residents deactivate drugs by putting them in the Detera pouch, adding water, shaking, and throwing them away in the household garbage. DCHD will be issuing medium-sized Detera pouches that can deactivate up to 45 pills.

2nd Ward Commissioner Sheryl Forste-Grupp

Commissioner Forste-Grupp thanked all the residents that applied for positions on boards and commissions.

Commissioner also announced that she and the 7th and 8th Ward Commissioners will be holding their constituent meeting on January 25th at the CREC.

3rd Ward Commissioner Kevin McCloskey

Happy New Year to everyone! Commissioner McCloskey stated that the 3rd Ward has a lot of storm water issues and now with the major rain storm in the works; there will be many more issues.

5th Ward Commissioner Laura Cavender

Commissioner Cavender offered her congratulations to Dave Burman upon his reappointment.

Discover Haverford will hold a Meet and Greet at the Grange from 5:30 to 7:30 on Wednesday, January 10th

She also announced that Monday is Martin Luther King Day and that there will be a lot of service projects going on in the township.

7th Ward Commissioner Conor Quinn

Commissioner Quinn announced that NBC is sponsoring the Eagles Road to Victory Bus - which will be in Brookline Boulevard lot at 12:30 on Thursday. Come out and cheer them on.

8th Ward Commissioner Gerry Hart

Commissioner Hart also highlight Wards 8, 2 and 7 constituent meeting on January 25 at 7 p.m. He also welcomed Commissioner McCollum to his first meeting.

9th Ward Commissioner Mike McCollum

Commissioner McCollum thanked both Township Manager Dave Burman and Chief John Viola for providing him a tour. He thanked everyone for the welcome.

He plans on working directly with the Hilltop Civic Association to plan good community events.

4th Ward Commissioner Judy Trombetta

Haverford Township is excited to announce the launch of the Business Revitalization and Modernization Matching Grant Program! Applications will be accepted starting January 15, 2024, through February 16, 2024, at 4:00 p.m. To get a head start on preparing your application, explore the newly released scoring rubric available on the website.

This matching grant may cover expenses related to renovating interior business and dining areas, improving exterior façade and outdoor seating spaces, purchasing and/or installing energy-efficient equipment, or implementing technology upgrades to enhance online purchasing and customer engagement.

6th Ward Commissioner Larry Holmes

Commissioner Holmes told everyone to drive safely during the heavy rain storm. 2024 will be a very significant year for America. He ended by quoting Martin Luther King.

All Commissioners agreed to adjourn.

Haverford Township
Disbursements for Approval - Warrant # 2 - 2024
February 12, 2024

(Formatted for ADA Accessibility)

| | | | |
|--|--|----|--------------|
| General Fund | | \$ | 2,022,441.19 |
| Sewer Fund | | \$ | 214,974.93 |
| Community Development Block Grant Fund | | \$ | 44,344.81 |
| Capital Projects Fund | | \$ | 683,742.25 |
| American Rescue Plan Fund | | \$ | 83,265.05 |
| Total | | \$ | 3,048,768.23 |

Payroll for January 18, 2024

| | | | |
|--------------|----|------------|---------------|
| General Fund | \$ | 902,570.25 | |
| Sewer Fund | \$ | 19,422.51 | \$ 921,992.76 |

Payroll for February 1, 2024

| | | | |
|--------------|----|------------|---------------|
| General Fund | \$ | 765,891.27 | |
| Sewer Fund | \$ | 20,857.10 | \$ 786,748.37 |

Credit Card Statement Ending January 27, 2024

\$ 12,833.49

Total Disbursements

\$ 4,770,342.85

These bills have been approved by the respective department heads, the Assistant Township Manager and Township Manager. Additionally, they have been processed by the Finance Department and are within total 2024 budgetary limits as imposed by the Board of Commissioners at its December 11, 2023 stated meeting.

Submitted to and approved by the Board of Commissioners this 12th day February, 2024

Haverford Township
 Invoices by GL Distribution Account
 (Formatted for ADA Accessibility)

| Invoice GL Account Title | Payee | Invoice Date | Description | GL Period Date | Check Amount | Check Issue Date | Check Number |
|----------------------------------|-------------------------------------|--------------|---|----------------|--------------|------------------|--------------|
| American Rescue Plan Fund | | | | | | | |
| 3440907402 | | | | | | | |
| ARPA - Economic Impacts | All Seasons Landscaping Co. Inc. | 1/8/2024 | WCP Median Landscaping | 1/31/2024 | \$ 21,490.00 | 2/12/2024 | 7102 |
| ARPA - Economic Impacts | Pennoni Associates, Inc | 2/1/2024 | West Chester Pike Median Landscaping | 1/31/2024 | \$ 870.00 | 2/12/2024 | 7107 |
| ARPA - Economic Impacts | Pennoni Associates, Inc | 2/1/2024 | Darby Road Streetscape - Phase 3 | 1/31/2024 | \$ 772.25 | 2/12/2024 | 7107 |
| Total 03440907402: | | | | | \$ 23,132.25 | | |
| 3440907502 | | | | | | | |
| ARPA - General Government | Element Environmental Solutions Inc | 12/29/2023 | Asbestos Inspect - 1 Mill Rd | 1/31/2024 | \$ 1,020.00 | 2/12/2024 | 7103 |
| ARPA - General Government | Element Environmental Solutions Inc | 1/23/2024 | Abatement Oversight - 1 Mill Rd | 1/31/2024 | \$ 1,645.00 | 2/12/2024 | 7103 |
| ARPA - General Government | Pennoni Associates, Inc | 2/1/2024 | Twp Bldg Electric Vehicle Charging Station | 1/31/2024 | \$ 147.50 | 2/12/2024 | 7107 |
| Total 03440907502: | | | | | \$ 2,812.50 | | |
| 3440907602 | | | | | | | |
| ARPA - Water, Sewer, Broadband | N Abbonizio Contractors, Inc | 2/2/2024 | Storm Sewer Replacement - Frederick Rd to Ellis Rd | 1/31/2024 | \$ 23,516.08 | 2/12/2024 | 7105 |
| ARPA - Water, Sewer, Broadband | Penndot | 10/2/2023 | Brookline Blvd Project (HOP #06114940) | 1/31/2024 | \$ 140.00 | 2/12/2024 | 7106 |
| ARPA - Water, Sewer, Broadband | Pennoni Associates, Inc | 2/1/2024 | S/S Township Wide | 1/31/2024 | \$ 2,136.75 | 2/12/2024 | 7107 |
| ARPA - Water, Sewer, Broadband | Pennoni Associates, Inc | 2/1/2024 | Bailey Park - 2022 Small Water_Sewer Grant | 1/31/2024 | \$ 105.00 | 2/12/2024 | 7107 |
| ARPA - Water, Sewer, Broadband | Pennoni Associates, Inc | 2/1/2024 | Brookline Blvd Sewer Replacement | 1/31/2024 | \$ 290.00 | 2/12/2024 | 7107 |
| ARPA - Water, Sewer, Broadband | Pennoni Associates, Inc | 2/1/2024 | County Line Road Sewer Lining | 1/31/2024 | \$ 641.00 | 2/12/2024 | 7107 |
| ARPA - Water, Sewer, Broadband | Pennoni Associates, Inc | 2/1/2024 | Crescent Hill_Francis Drive Lining | 1/31/2024 | \$ 140.00 | 2/12/2024 | 7107 |
| ARPA - Water, Sewer, Broadband | Pennoni Associates, Inc | 2/1/2024 | Cobbs Creek Interceptor Buttressing | 1/31/2024 | \$ 527.50 | 2/12/2024 | 7107 |
| ARPA - Water, Sewer, Broadband | Pennoni Associates, Inc | 2/1/2024 | Storm Sewer Replacement - Frederick Rd to Ellis Rd | 1/31/2024 | \$ 36.25 | 2/12/2024 | 7107 |
| ARPA - Water, Sewer, Broadband | Pennoni Associates, Inc | 2/1/2024 | Northbrook Stream Restoration | 1/31/2024 | \$ 7,770.00 | 2/12/2024 | 7107 |
| ARPA - Water, Sewer, Broadband | Pennoni Associates, Inc | 2/1/2024 | Cobbs Creek Stream Restoration | 1/31/2024 | \$ 4,897.00 | 2/12/2024 | 7107 |
| ARPA - Water, Sewer, Broadband | Pennoni Associates, Inc | 2/1/2024 | Dill Road Storm Sewer Lining | 1/31/2024 | \$ 140.00 | 2/12/2024 | 7107 |
| Total 03440907602: | | | | | \$ 40,339.58 | | |
| 3440907802 | | | | | | | |
| ARPA - Disprpt'ly Impctd | Christine Fanelli | 12/28/2023 | Senior Economic Recovery Payment | 1/31/2024 | \$ 500.00 | 1/9/2024 | 7091 |
| ARPA - Disprpt'ly Impctd | Julio S. Paz Y Mino | 1/10/2024 | Senior Economic Recovery Payment | 1/31/2024 | \$ 500.00 | 1/16/2024 | 7094 |
| ARPA - Disprpt'ly Impctd | LogoWear House Inc | 9/29/2023 | (200) Shirts - Senior/Fitness Expo TShirts (10/01/23) | 1/31/2024 | \$ 980.00 | 1/16/2024 | 7095 |
| ARPA - Disprpt'ly Impctd | Edward Konieczny | 1/22/2024 | Senior Economic Recovery Payment | 1/31/2024 | \$ 500.00 | 1/23/2024 | 7096 |
| ARPA - Disprpt'ly Impctd | Maryann Dugan | 1/25/2024 | Senior Economic Recovery Payment | 1/31/2024 | \$ 500.00 | 1/23/2024 | 7097 |
| ARPA - Disprpt'ly Impctd | Maryann Dugan | 1/25/2024 | Senior Economic Recovery Payment | 1/31/2024 | \$ (500.00) | 1/29/2024 | 7097 |
| ARPA - Disprpt'ly Impctd | Scott Selkowitz | 1/24/2024 | Reimb - Senior Game Night | 1/31/2024 | \$ 80.62 | 1/23/2024 | 7098 |
| ARPA - Disprpt'ly Impctd | Scott Selkowitz | 1/24/2024 | Reimb - Senior Game Night | 1/31/2024 | \$ (80.62) | 1/29/2024 | 7098 |
| ARPA - Disprpt'ly Impctd | Maryann Dugan | 1/25/2024 | Senior Economic Recovery Payment | 1/31/2024 | \$ 500.00 | 1/30/2024 | 7099 |
| ARPA - Disprpt'ly Impctd | Scott Selkowitz | 1/24/2024 | Reimb - Senior Game Night | 1/31/2024 | \$ 80.62 | 1/30/2024 | 7100 |
| ARPA - Disprpt'ly Impctd | Dolores E Brough | 1/31/2024 | Senior Economic Recovery Payment | 2/29/2024 | \$ 500.00 | 2/6/2024 | 7101 |
| ARPA - Disprpt'ly Impctd | Pennoni Associates, Inc | 2/1/2024 | Township Line Sidewalks | 1/31/2024 | \$ 326.25 | 2/12/2024 | 7107 |
| Total 03440907802: | | | | | \$ 3,886.87 | | |
| 3440908102 | | | | | | | |
| ARPA - Health Response | FencCo Inc | 1/18/2024 | Install Chain Link Fence - McDonald Field | 1/31/2024 | \$ 11,000.00 | 2/12/2024 | 7104 |
| ARPA - Health Response | Pennoni Associates, Inc | 1/25/2024 | Grange_Preston Basketball Court Reno | 1/31/2024 | \$ 372.60 | 2/12/2024 | 7107 |
| ARPA - Health Response | Pennoni Associates, Inc | 2/1/2024 | Darby Creek Trails - Southern Extension | 1/31/2024 | \$ 1,721.25 | 2/12/2024 | 7107 |
| Total 03440908102: | | | | | \$ 13,093.85 | | |
| Total American Rescue Plan Fund: | | | | | \$ 83,265.05 | | |
| Capital Fund | | | | | | | |
| 18440907302 | | | | | | | |
| Capital Projects | Pennoni Associates, Inc | 2/1/2024 | Raymond Drive Basin | 1/31/2024 | \$ 3,441.25 | 2/12/2024 | 1138 |
| Capital Projects | Richard E Pierson Construction Inc | 12/14/2023 | Pennsy Trail Construction App #3 | 1/31/2024 | \$ 96,590.05 | 1/16/2024 | 1415 |
| Capital Projects | Traffic Planning and Design, Inc | 12/6/2023 | Construction Inspec - Pennsy Trail | 1/31/2024 | \$ 17,420.30 | 1/16/2024 | 1416 |
| Capital Projects | CDW Government Inc | 1/13/2024 | HPE Server | 1/31/2024 | \$ 13,115.50 | 2/12/2024 | 1417 |
| Capital Projects | Herbert Rowland and Grubic, Inc | 1/12/2024 | Parks & Rec Open Space Plan | 1/31/2024 | \$ 3,757.22 | 2/12/2024 | 1418 |

| | | | | | | | | |
|--------------------------|--|------------|---|-----------|----|------------|-----------|------|
| Capital Projects | Michael Baker International, Inc | 1/11/2024 | Wynnefield Drive Flood Study | 1/31/2024 | \$ | 12,364.98 | 2/12/2024 | 1419 |
| Capital Projects | Pennoni Associates, Inc | 2/1/2024 | DCED Trans Grant Mill & Karakung | 1/31/2024 | \$ | 458.25 | 2/12/2024 | 1420 |
| Capital Projects | Pennoni Associates, Inc | 2/1/2024 | Pennsy Trail - Phase II | 1/31/2024 | \$ | 729.50 | 2/12/2024 | 1420 |
| Capital Projects | Pennoni Associates, Inc | 2/1/2024 | CREC Electric Vehicle Charging Station | 1/31/2024 | \$ | 6,986.00 | 2/12/2024 | 1420 |
| Capital Projects | Signal Service, Inc | 10/6/2023 | Earlington & Mill | 1/31/2024 | \$ | 14,887.40 | 2/12/2024 | 1421 |
| Capital Projects | Wiss, Janney, Elstner Associates, Inc. | 1/16/2024 | Veneer Failure Investigation | 1/31/2024 | \$ | 1,797.40 | 2/12/2024 | 1422 |
| Capital Projects | McCloskey Mechanical Contractors, Inc | 2/1/2024 | Skatium Cooling Towers Replacement | 1/31/2024 | \$ | 67,321.80 | 2/12/2024 | 7016 |
| Capital Projects | Pennoni Associates, Inc | 2/1/2024 | Skatium Cooling Towers | 1/31/2024 | \$ | 5,473.00 | 2/12/2024 | 7017 |
| Capital Projects | Pennoni Associates, Inc | 2/1/2024 | Skatium Locker Room Renovations | 1/31/2024 | \$ | 333.75 | 2/12/2024 | 7017 |
| Capital Projects | Schipsi Electric, LLC | 2/1/2024 | Skatium Cooling Towers Replacement | 1/31/2024 | \$ | 5,492.70 | 2/12/2024 | 7018 |
| Capital Projects | Flag Products Inc | 10/31/2023 | Signage Balance - Temp Library Location | 1/31/2024 | \$ | 3,589.50 | 1/16/2024 | 8055 |
| Capital Projects | AJM Electric, Inc | 1/25/2024 | Library - Prime (Electrical) | 1/31/2024 | \$ | 17,775.00 | 2/12/2024 | 8056 |
| Capital Projects | Bernardon Architects | 1/18/2024 | Haverford Township Library | 1/31/2024 | \$ | 6,241.36 | 2/12/2024 | 8057 |
| Capital Projects | Bristol Environmental inc | 11/12/2023 | Mold Remediation - 2325 Darby Rd | 1/31/2024 | \$ | 12,300.00 | 2/12/2024 | 8058 |
| Capital Projects | C.B. Development Services, Inc | 1/9/2024 | Haverford Township Library | 1/31/2024 | \$ | 31,950.00 | 2/12/2024 | 8059 |
| Capital Projects | C.B. Development Services, Inc | 1/30/2024 | Haverford Township Library | 1/31/2024 | \$ | 31,950.00 | 2/12/2024 | 8059 |
| Capital Projects | Corcoran Drilling Co Inc | 12/30/2023 | Haverford Township Library Parking Lot | 1/31/2024 | \$ | 1,950.00 | 2/12/2024 | 8060 |
| Capital Projects | David Blackmore & Associates Inc | 1/12/2024 | Geotechnical Exploration - Haverford Township Library | 1/31/2024 | \$ | 4,698.48 | 2/12/2024 | 8061 |
| Capital Projects | Delaware County Intermediate Unit | 1/12/2024 | IT - Temporary Locations | 1/31/2024 | \$ | 12,754.08 | 2/12/2024 | 8062 |
| Capital Projects | Dolan Mechanical, Inc | 1/31/2024 | Library - Prime (HVAC) | 1/31/2024 | \$ | 69,210.00 | 2/12/2024 | 8063 |
| Capital Projects | Dolan Mechanical, Inc | 1/31/2024 | Library - Prime (Plumbing) | 1/31/2024 | \$ | 54,925.20 | 2/12/2024 | 8063 |
| Capital Projects | Element Environmental Solutions Inc | 8/22/2023 | UST Removal - 1601 Darby Rd | 1/31/2024 | \$ | 408.00 | 2/12/2024 | 8064 |
| Capital Projects | Element Environmental Solutions Inc | 12/29/2023 | UST Removal - 1601 Darby Rd | 1/31/2024 | \$ | 1,153.35 | 2/12/2024 | 8064 |
| Capital Projects | Element Environmental Solutions Inc | 12/29/2023 | Mold Reporting - 2325 Darby Rd | 1/31/2024 | \$ | 1,046.50 | 2/12/2024 | 8064 |
| Capital Projects | Element Environmental Solutions Inc | 12/29/2023 | Abatement Oversight - 1601 Darby Rd | 1/31/2024 | \$ | 6,000.00 | 2/12/2024 | 8064 |
| Capital Projects | Excel Elevator & Escalator LLC | 12/27/2023 | Elevator Repair - 1601 Darby Rd | 1/31/2024 | \$ | 850.00 | 2/12/2024 | 8065 |
| Capital Projects | Keystone Municipal Services, Inc | 12/30/2023 | Plan Review (Library) | 1/31/2024 | \$ | 37.50 | 2/12/2024 | 8066 |
| Capital Projects | Pennoni Associates, Inc | 2/1/2024 | Township Building Solar | 1/31/2024 | \$ | 848.75 | 2/12/2024 | 8067 |
| Capital Projects | Rycon Construction, Inc | 1/26/2024 | Library - Prime (GC) | 1/31/2024 | \$ | 164,159.78 | 2/12/2024 | 8068 |
| Capital Projects | Spidernet Technical Consulting, LLC | 12/31/2023 | IT - Temporary Locations | 1/31/2024 | \$ | 7,203.52 | 2/12/2024 | 8069 |
| Capital Projects | Spidernet Technical Consulting, LLC | 12/31/2023 | IT - Temporary Locations | 1/31/2024 | \$ | 4,522.13 | 2/12/2024 | 8069 |
| | Total 18440907302: | | | | \$ | 683,742.25 | | |
| | Total Capital Fund: | | | | \$ | 683,742.25 | | |
| CDBG Grant Fund | | | | | | | | |
| 4494750602 | | | | | | | | |
| Administration | Anthony J Dunleavy Assoc Inc | 2/1/2024 | 48th Yr Rehab | 1/31/2024 | \$ | 11,700.00 | 2/12/2024 | 4773 |
| | Total 04494750602: | | | | \$ | 11,700.00 | | |
| 4494750802 | | | | | | | | |
| Public Projects | S.B. Conrad, Inc | 12/19/2023 | Grange/Preston Basketball Court Restoration | 1/31/2024 | \$ | 7,040.06 | 1/9/2024 | 4771 |
| Public Projects | Pennoni Associates, Inc | 1/24/2024 | Grange Estate Necessary Roof | 1/31/2024 | \$ | 72.50 | 2/12/2024 | 4775 |
| | Total 04494750802: | | | | \$ | 7,112.56 | | |
| 4494751302 | | | | | | | | |
| Rehabilitation | AJP Contractors Inc | 1/16/2024 | 717 Aubrey Ave | 1/31/2024 | \$ | 2,700.00 | 2/12/2024 | 4772 |
| Rehabilitation | Leadco Environmental Services Inc | 11/17/2023 | 2421 Wynnefield Dr | 1/31/2024 | \$ | 1,759.00 | 2/12/2024 | 4774 |
| Rehabilitation | Pennoni Associates, Inc | 1/25/2024 | Misc HUD Inspections | 1/31/2024 | \$ | 616.25 | 2/12/2024 | 4775 |
| | Total 04494751302: | | | | \$ | 5,075.25 | | |
| 4495750602 | | | | | | | | |
| Administration | Anthony J Dunleavy Assoc Inc | 2/1/2024 | 49th Yr Admin | 1/31/2024 | \$ | 13,300.00 | 2/12/2024 | 4773 |
| | Total 04495750602: | | | | \$ | 13,300.00 | | |
| 4495750802 | | | | | | | | |
| Public Projects | Pennoni Associates, Inc | 12/22/2023 | Grange_Preston Basketball Court Reno | 1/31/2024 | \$ | 981.60 | 1/9/2024 | 4770 |
| Public Projects | Pennoni Associates, Inc | 1/25/2024 | Grange_Preston Basketball Court Reno | 1/31/2024 | \$ | 662.40 | 2/12/2024 | 4775 |
| | Total 04495750802: | | | | \$ | 1,644.00 | | |
| 4495751402 | | | | | | | | |
| Senior Citizens Services | Surrey Services for Seniors | 12/1/2023 | 49th Yr Senior Center | 1/31/2024 | \$ | 5,513.00 | 2/12/2024 | 4776 |
| | Total 04495751402: | | | | \$ | 5,513.00 | | |
| | Total CDBG Grant Fund: | | | | \$ | 44,344.81 | | |

General Fund

| | | | | | | | | |
|-----------------------------|---------------------------------------|------------|---|-----------|----|-----------|-----------|--------|
| 110007 | | | | | | | | |
| Cash on Hand - Skatium | Petty Cash - Haverford Township | 1/18/2024 | For POS - Skatium | 1/31/2024 | \$ | 300.00 | 1/23/2024 | 182305 |
| Total 0110007: | | | | | \$ | 300.00 | | |
| 113000 | | | | | | | | |
| Due From Other Funds | Peco Energy | 12/28/2023 | Lawrence Rd - Darby Creek | 1/31/2024 | \$ | 4.67 | 1/9/2024 | 182256 |
| Due From Other Funds | Peco Energy | 12/28/2023 | Darby Creek - Ellis | 1/31/2024 | \$ | 4.67 | 1/9/2024 | 182256 |
| Due From Other Funds | Peco Energy | 12/28/2023 | Marple Rd - Darby Creek | 1/31/2024 | \$ | 4.67 | 1/9/2024 | 182256 |
| Due From Other Funds | Peco Energy | 12/28/2023 | Bon Air - Darby Creek | 1/31/2024 | \$ | 4.67 | 1/9/2024 | 182256 |
| Due From Other Funds | Peco Energy | 12/28/2023 | Glendale Rd - Darby Creek | 1/31/2024 | \$ | 4.67 | 1/9/2024 | 182256 |
| Due From Other Funds | Peco Energy | 12/28/2023 | 3800 Darby Rd | 1/31/2024 | \$ | 4.67 | 1/9/2024 | 182256 |
| Due From Other Funds | Peco Energy | 12/28/2023 | West Chester Pk - Walnut Hill | 1/31/2024 | \$ | 4.67 | 1/9/2024 | 182256 |
| Due From Other Funds | Postmaster | 1/26/2024 | 2024 Tax Bill Postage | 1/31/2024 | \$ | 3,531.93 | 1/26/2024 | 182310 |
| Due From Other Funds | Peco Energy | 1/29/2024 | Lawrence Rd - Darby Creek | 2/29/2024 | \$ | 4.69 | 2/6/2024 | 182339 |
| Due From Other Funds | Peco Energy | 1/29/2024 | Darby Creek - Ellis | 2/29/2024 | \$ | 4.69 | 2/6/2024 | 182339 |
| Due From Other Funds | Peco Energy | 1/29/2024 | Marple Rd - Darby Creek | 2/29/2024 | \$ | 4.69 | 2/6/2024 | 182339 |
| Due From Other Funds | Peco Energy | 1/29/2024 | Bon Air - Darby Creek | 2/29/2024 | \$ | 4.69 | 2/6/2024 | 182339 |
| Due From Other Funds | Peco Energy | 1/29/2024 | Glendale Rd - Darby Creek | 2/29/2024 | \$ | 4.69 | 2/6/2024 | 182339 |
| Due From Other Funds | Peco Energy | 1/29/2024 | 3800 Darby Rd | 2/29/2024 | \$ | 4.69 | 2/6/2024 | 182339 |
| Due From Other Funds | Peco Energy | 1/29/2024 | West Chester Pk - Walnut Hill | 2/29/2024 | \$ | 4.69 | 2/6/2024 | 182339 |
| Total 0113000: | | | | | \$ | 3,597.45 | | |
| 123900 | | | | | | | | |
| Over and Duplicate Payments | Diane M Hannold | 1/5/2024 | Overpym't RE Taxes #22030165700 | 1/31/2024 | \$ | 81.34 | 1/16/2024 | 182273 |
| Total 0123900: | | | | | \$ | 81.34 | | |
| 1360360601 | | | | | | | | |
| Bulk Trash Fees | Rachel Loev | 1/24/2024 | Refund - Canceled Bulk | 1/31/2024 | \$ | 22.00 | 1/30/2024 | 182323 |
| Total 01360360601: | | | | | \$ | 22.00 | | |
| 1360364101 | | | | | | | | |
| Lessons | Kate D'Arcy Edmiston | 1/11/2024 | Refund - Canceled Lessons | 1/31/2024 | \$ | 150.00 | 1/16/2024 | 182283 |
| Total 01360364101: | | | | | \$ | 150.00 | | |
| 1400150002 | | | | | | | | |
| Life Insurance | North American Benefits Company | 1/22/2024 | Group Term Life Insurance | 1/31/2024 | \$ | 172.80 | 1/30/2024 | 182320 |
| Total 01400150002: | | | | | \$ | 172.80 | | |
| 1400150502 | | | | | | | | |
| Health Benefits | DelCo Public Schools Healthcare Trst | 1/2/2024 | Health Benefits | 1/31/2024 | \$ | 22,485.91 | 1/16/2024 | 182272 |
| Total 01400150502: | | | | | \$ | 22,485.91 | | |
| 1400151002 | | | | | | | | |
| Rx/Dental/Vision/LTD | Express Scripts Inc | 1/2/2024 | Prescription Benefits | 1/31/2024 | \$ | 836.67 | 1/9/2024 | 422 |
| Rx/Dental/Vision/LTD | Express Scripts Inc | 1/12/2024 | Prescription Benefits | 1/31/2024 | \$ | 1,276.31 | 1/12/2024 | 426 |
| Rx/Dental/Vision/LTD | Express Scripts Inc | 1/22/2024 | Prescription Benefits | 1/31/2024 | \$ | 739.43 | 1/30/2024 | 430 |
| Rx/Dental/Vision/LTD | Express Scripts Inc | 1/2/2024 | Prescription Benefits | 1/31/2024 | \$ | 836.67 | 1/9/2024 | 7092 |
| Rx/Dental/Vision/LTD | Express Scripts Inc | 1/2/2024 | Prescription Benefits | 1/31/2024 | \$ | (836.67) | 1/9/2024 | 7092 |
| Rx/Dental/Vision/LTD | North American Benefits Company | 1/22/2024 | Long Term Civilian Disability Insurance | 2/29/2024 | \$ | 132.59 | 2/6/2024 | 182337 |
| Total 01400151002: | | | | | \$ | 2,985.00 | | |
| 1400152002 | | | | | | | | |
| Workers Compensation | Arthur J Gallagher Risk Mgmt Serv Inc | 1/8/2024 | 2022 WC Audit | 1/31/2024 | \$ | 221.73 | 1/16/2024 | 182263 |
| Total 01400152002: | | | | | \$ | 221.73 | | |
| 1400200002 | | | | | | | | |
| Miscellaneous Expense | Bridgee Bees Floral Creations LLC | 1/19/2024 | Speedy Recovery - L Latanzio | 1/31/2024 | \$ | 70.00 | 2/12/2024 | 182370 |
| Miscellaneous Expense | Spike's Trophies Limited | 11/25/2023 | Desk Name Plate - M McCollum | 1/31/2024 | \$ | 95.00 | 2/12/2024 | 182494 |
| Total 01400200002: | | | | | \$ | 165.00 | | |
| 1400200102 | | | | | | | | |
| Commissioners Expense | Dawn Griffin | 1/12/2024 | Deposit - BOC Childrens Outreach Books | 1/31/2024 | \$ | 675.00 | 1/16/2024 | 182269 |
| Commissioners Expense | Strassheim Digital Imaging | 1/16/2024 | Postage & Delivery - Ward 2, 7, 8 Mgt | 1/31/2024 | \$ | 1,656.61 | 1/23/2024 | 182307 |
| Commissioners Expense | Strassheim Digital Imaging | 1/17/2024 | Postcard Printing - Ward 2, 7, 8 Mtg | 1/31/2024 | \$ | 2,195.00 | 1/23/2024 | 182307 |
| Commissioners Expense | AT & T Mobility | 1/16/2024 | Cellular Service | 2/29/2024 | \$ | 402.55 | 2/6/2024 | 182331 |
| Commissioners Expense | Suzanne Guelli | 1/9/2024 | Ward 2, 7, 8 Postcard | 2/29/2024 | \$ | 100.00 | 2/6/2024 | 182343 |
| Commissioners Expense | D M I Home Supply | 12/13/2023 | Holiday Party for Employees | 1/31/2024 | \$ | 518.00 | 2/12/2024 | 182384 |
| Commissioners Expense | Taddeo's Greenhouse Inc | 12/12/2023 | Holiday Flowers - Employee Luncheon | 1/31/2024 | \$ | 120.00 | 2/12/2024 | 182500 |

| | | | | | | | | |
|--------------------------|---------------------------------------|------------|---|-----------|----|----------|-----------|--------|
| Total 01400200102: | | | | | \$ | 5,667.16 | | |
| 1400200202 | | | | | | | | |
| Office Supplies | Office Basics, Inc | 12/11/2023 | Office Supplies | 1/31/2024 | \$ | 70.54 | 2/12/2024 | 182462 |
| Office Supplies | Office Basics, Inc | 1/2/2024 | Office Supplies | 1/31/2024 | \$ | 9.40 | 2/12/2024 | 182462 |
| Office Supplies | Office Basics, Inc | 1/4/2024 | Office Supplies | 1/31/2024 | \$ | 81.93 | 2/12/2024 | 182462 |
| Office Supplies | Office Basics, Inc | 1/23/2024 | Office Supplies | 1/31/2024 | \$ | 96.08 | 2/12/2024 | 182462 |
| Office Supplies | Office Basics, Inc | 1/24/2024 | Office Supplies | 1/31/2024 | \$ | 20.32 | 2/12/2024 | 182462 |
| Office Supplies | Office Basics, Inc | 1/26/2024 | Office Supplies | 1/31/2024 | \$ | 9.40 | 2/12/2024 | 182462 |
| Office Supplies | Office Basics, Inc | 1/30/2024 | Office Supplies | 1/31/2024 | \$ | 18.30 | 2/12/2024 | 182462 |
| Total 01400200202: | | | | | \$ | 305.97 | | |
| 1400210102 | | | | | | | | |
| Postage Expense | FP Finance Program | 12/27/2023 | Postage Meter Lease | 1/31/2024 | \$ | 8.75 | 1/9/2024 | 182250 |
| Postage Expense | FP Finance Program | 1/29/2024 | Postage Meter Lease | 2/29/2024 | \$ | 8.75 | 2/6/2024 | 182335 |
| Total 01400210102: | | | | | \$ | 17.50 | | |
| 1400210202 | | | | | | | | |
| Ordinance Book Updating | General Code | 1/1/2024 | Ordinance Book Updating | 1/31/2024 | \$ | 1,195.00 | 2/12/2024 | 182411 |
| Ordinance Book Updating | General Code | 1/31/2024 | Ordinance Book Updating | 1/31/2024 | \$ | 1,155.00 | 2/12/2024 | 182411 |
| Total 01400210202: | | | | | \$ | 2,350.00 | | |
| 1400210602 | | | | | | | | |
| Advertising | 21st Century Media-Philly Cluster | 12/15/2023 | Advertising | 1/31/2024 | \$ | 158.03 | 2/12/2024 | 182346 |
| Advertising | 21st Century Media-Philly Cluster | 12/15/2023 | Advertising | 1/31/2024 | \$ | 106.01 | 2/12/2024 | 182346 |
| Advertising | 21st Century Media-Philly Cluster | 12/15/2023 | Advertising | 1/31/2024 | \$ | 106.01 | 2/12/2024 | 182346 |
| Advertising | 21st Century Media-Philly Cluster | 12/15/2023 | Advertising | 1/31/2024 | \$ | 93.17 | 2/12/2024 | 182346 |
| Advertising | 21st Century Media-Philly Cluster | 12/15/2023 | Advertising | 1/31/2024 | \$ | 1,275.19 | 2/12/2024 | 182346 |
| Advertising | 21st Century Media-Philly Cluster | 1/7/2024 | Advertising | 1/31/2024 | \$ | 58.29 | 2/12/2024 | 182346 |
| Advertising | 21st Century Media-Philly Cluster | 1/12/2024 | Advertising | 1/31/2024 | \$ | 124.57 | 2/12/2024 | 182346 |
| Advertising | 21st Century Media-Philly Cluster | 1/12/2024 | Advertising | 1/31/2024 | \$ | 109.22 | 2/12/2024 | 182346 |
| Advertising | 21st Century Media-Philly Cluster | 1/12/2024 | Advertising | 1/31/2024 | \$ | 96.38 | 2/12/2024 | 182346 |
| Total 01400210602: | | | | | \$ | 2,126.87 | | |
| 1400260202 | | | | | | | | |
| Training | APMM | 1/8/2024 | APMM Executive Development Conference | 1/31/2024 | \$ | 400.00 | 1/16/2024 | 182261 |
| Training | Pennsylvania State Assoc. of Boroughs | 1/31/2024 | Webinar - D Burman | 2/29/2024 | \$ | 30.00 | 2/6/2024 | 182340 |
| Total 01400260202: | | | | | \$ | 430.00 | | |
| 1400290202 | | | | | | | | |
| Legal Expenses | Kilkenny Law, LLC | 1/2/2024 | Legal Services - General | 1/31/2024 | \$ | 3,132.50 | 2/12/2024 | 182437 |
| Total 01400290202: | | | | | \$ | 3,132.50 | | |
| 1400290302 | | | | | | | | |
| Prof Services - Special | Kilkenny Law, LLC | 1/2/2024 | Legal Services - Tax Appeals | 1/31/2024 | \$ | 87.50 | 2/12/2024 | 182437 |
| Prof Services - Special | Kilkenny Law, LLC | 1/2/2024 | Legal Services - General | 1/31/2024 | \$ | 503.75 | 2/12/2024 | 182437 |
| Prof Services - Special | McNichol, Byrne, & Matlawski, PC | 1/17/2024 | Legal services - Veneer | 1/31/2024 | \$ | 17.50 | 2/12/2024 | 182451 |
| Prof Services - Special | McNichol, Byrne, & Matlawski, PC | 1/17/2024 | Legal services - Steubner | 1/31/2024 | \$ | 472.50 | 2/12/2024 | 182451 |
| Total 01400290302: | | | | | \$ | 1,081.25 | | |
| 1400300002 | | | | | | | | |
| Communications | Comcast | 1/2/2024 | Cable Service - 1014 Darby Rd | 1/31/2024 | \$ | 198.76 | 1/16/2024 | 182266 |
| Communications | Comcast Business | 1/1/2024 | Cable Service | 1/31/2024 | \$ | 45.58 | 1/16/2024 | 182268 |
| Communications | Xtel Communications, Inc | 1/1/2024 | Phone Expense | 1/31/2024 | \$ | 20.73 | 1/16/2024 | 182293 |
| Communications | AT & T Mobility | 1/16/2024 | Cellular Service | 2/29/2024 | \$ | 44.73 | 2/6/2024 | 182331 |
| Total 01400300002: | | | | | \$ | 309.80 | | |
| 1400400002 | | | | | | | | |
| Copier Lease/Maintenance | Toshiba America Business Solutions | 12/25/2023 | Copier Maintenance | 1/31/2024 | \$ | 15.50 | 1/9/2024 | 182258 |
| Copier Lease/Maintenance | Toshiba Financial Service | 12/28/2023 | Copier Lease | 1/31/2024 | \$ | 51.46 | 1/9/2024 | 182259 |
| Copier Lease/Maintenance | Toshiba Financial Service | 1/23/2024 | Copier Lease | 1/31/2024 | \$ | 51.46 | 1/30/2024 | 182326 |
| Copier Lease/Maintenance | Toshiba America Business Solutions | 1/22/2024 | Copier Maintenance | 2/29/2024 | \$ | 9.00 | 2/6/2024 | 182344 |
| Total 01400400002: | | | | | \$ | 127.42 | | |
| 1400410602 | | | | | | | | |
| Public Officers/EPLI | Arthur J Gallagher Risk Mgmt Serv Inc | 12/18/2023 | P & C Insurance Premium â€" 3rd Installment | 1/31/2024 | \$ | 7,886.45 | 1/30/2024 | 182312 |
| Total 01400410602: | | | | | \$ | 7,886.45 | | |
| 1400411702 | | | | | | | | |
| Vehicle Insurance | Arthur J Gallagher Risk Mgmt Serv Inc | 12/18/2023 | P & C Insurance Premium â€" 3rd Installment | 1/31/2024 | \$ | 285.74 | 1/30/2024 | 182312 |

| | | | | | | | |
|-------------------------------|---------------------------------------|------------|---|-----------|---------------|-----------|--------|
| Tax Collection Fee | Tri-State Financial Group LLC | 1/4/2024 | Distribution of Tax Collection | 1/31/2024 | \$ 6,110.97 | 2/12/2024 | 182505 |
| Total 01402450002: | | | | | \$ 6,110.97 | | |
| 1406150002 | | | | | | | |
| Life Insurance | North American Benefits Company | 1/22/2024 | Group Term Life Insurance | 1/31/2024 | \$ 26.40 | 1/30/2024 | 182320 |
| Total 01406150002: | | | | | \$ 26.40 | | |
| 1406150502 | | | | | | | |
| Health Benefits | DelCo Public Schools Healthcare Trst | 1/2/2024 | Health Benefits | 1/31/2024 | \$ (8,199.50) | 1/16/2024 | 182272 |
| Total 01406150502: | | | | | \$ (8,199.50) | | |
| 1406151002 | | | | | | | |
| Rx/Dental/Vision/LTD | North American Benefits Company | 1/22/2024 | Long Term Civilian Disability Insurance | 2/29/2024 | \$ 56.26 | 2/6/2024 | 182337 |
| Total 01406151002: | | | | | \$ 56.26 | | |
| 1406152002 | | | | | | | |
| Workers Compensation | Arthur J Gallagher Risk Mgmt Serv Inc | 1/8/2024 | 2022 WC Audit | 1/31/2024 | \$ 93.36 | 1/16/2024 | 182263 |
| Total 01406152002: | | | | | \$ 93.36 | | |
| 1406200202 | | | | | | | |
| Office Supplies | Office Basics, Inc | 1/2/2024 | Office Supplies | 1/31/2024 | \$ 9.40 | 2/12/2024 | 182462 |
| Office Supplies | Office Basics, Inc | 1/24/2024 | Office Supplies | 1/31/2024 | \$ 20.32 | 2/12/2024 | 182462 |
| Office Supplies | Office Basics, Inc | 1/26/2024 | Office Supplies | 1/31/2024 | \$ 160.09 | 2/12/2024 | 182462 |
| Office Supplies | Office Basics, Inc | 1/26/2024 | Office Supplies | 1/31/2024 | \$ 9.40 | 2/12/2024 | 182462 |
| Office Supplies | Sir Speedy Printing Center #7099 | 1/18/2024 | (595) Workers Comp Cards | 1/31/2024 | \$ 165.00 | 2/12/2024 | 182492 |
| Office Supplies | Sir Speedy Printing Center #7099 | 1/26/2024 | (150) Benefit Information Cards | 1/31/2024 | \$ 83.00 | 2/12/2024 | 182492 |
| Total 01406200202: | | | | | \$ 447.21 | | |
| 1406200502 | | | | | | | |
| Computer Expense | PeopleGuru Inc | 1/1/2024 | Monthly Time & Attendance | 1/31/2024 | \$ 1,022.99 | 2/12/2024 | 182470 |
| Computer Expense | PeopleGuru Inc | 2/1/2024 | Monthly Time & Attendance | 1/31/2024 | \$ 1,208.59 | 2/12/2024 | 182470 |
| Total 01406200502: | | | | | \$ 2,231.58 | | |
| 1406210102 | | | | | | | |
| Postage Expense | FP Finance Program | 12/27/2023 | Postage Meter Lease | 1/31/2024 | \$ 6.25 | 1/9/2024 | 182250 |
| Postage Expense | FP Finance Program | 1/29/2024 | Postage Meter Lease | 2/29/2024 | \$ 6.25 | 2/6/2024 | 182335 |
| Total 01406210102: | | | | | \$ 12.50 | | |
| 1406222702 | | | | | | | |
| Admin Charge Prescriptions | Express Scripts Inc | 1/2/2024 | Prescription Benefits | 1/31/2024 | \$ 834.80 | 1/9/2024 | 421 |
| Admin Charge Prescriptions | Express Scripts Inc | 1/12/2024 | Prescription Benefits | 1/31/2024 | \$ 3.00 | 1/12/2024 | 425 |
| Admin Charge Prescriptions | Express Scripts Inc | 1/22/2024 | Prescription Benefits | 1/31/2024 | \$ 17.50 | 1/30/2024 | 429 |
| Admin Charge Prescriptions | Express Scripts Inc | 1/2/2024 | Prescription Benefits | 1/31/2024 | \$ 834.80 | 1/9/2024 | 7093 |
| Admin Charge Prescriptions | Express Scripts Inc | 1/2/2024 | Prescription Benefits | 1/31/2024 | \$ (834.80) | 1/9/2024 | 7093 |
| Total 01406222702: | | | | 855.3 | | | |
| 1406222802 | | | | | | | |
| Admin Charge Vision Plan | Vision Benefits of America | 1/5/2024 | Vision Benefits | 1/31/2024 | \$ 85.88 | 1/23/2024 | 182309 |
| Admin Charge Vision Plan | Vision Benefits of America | 1/5/2024 | Vision Benefits | 1/31/2024 | \$ 12.00 | 1/30/2024 | 182328 |
| Total 01406222802: | | | | | \$ 97.88 | | |
| 1406222902 | | | | | | | |
| Admin - EAP | Health Advocate Solutions Inc | 1/15/2024 | Employee Assistance Program | 1/31/2024 | \$ 1,420.80 | 2/12/2024 | 182419 |
| Total 01406222902: | | | | | \$ 1,420.80 | | |
| 1406225102 | | | | | | | |
| PA Unemployment Compensation | PA Dept of Labor & Industry | 1/11/2024 | 4Q23 Unemployment Claims | 1/31/2024 | \$ 2,782.19 | 1/12/2024 | 424 |
| Total 01406225102: | | | | | \$ 2,782.19 | | |
| 1406300002 | | | | | | | |
| Communications | Comcast Business | 1/1/2024 | Cable Service | 1/31/2024 | \$ 30.93 | 1/16/2024 | 182268 |
| Communications | Xtel Communications, Inc | 1/1/2024 | Phone Expense | 1/31/2024 | \$ 14.07 | 1/16/2024 | 182293 |
| Total 01406300002: | | | | | \$ 45.00 | | |
| 1406310002 | | | | | | | |
| Civilian Drug/Background Test | MLH Occupational & Travel Health | 11/2/2023 | Drug Test | 1/31/2024 | \$ 106.00 | 1/16/2024 | 182286 |
| Civilian Drug/Background Test | MLH Occupational & Travel Health | 1/2/2024 | Drug Test | 1/31/2024 | \$ 106.00 | 1/16/2024 | 182286 |
| Civilian Drug/Background Test | MLH Occupational & Travel Health | 1/2/2024 | Drug Test | 1/31/2024 | \$ 106.00 | 2/12/2024 | 182454 |
| Total 01406310002: | | | | | \$ 318.00 | | |
| 1406400002 | | | | | | | |
| Copier Lease/Maintenance | Toshiba America Business Solutions | 12/25/2023 | Copier Maintenance | 1/31/2024 | \$ 15.50 | 1/9/2024 | 182258 |
| Copier Lease/Maintenance | Toshiba Financial Service | 12/28/2023 | Copier Lease | 1/31/2024 | \$ 51.46 | 1/9/2024 | 182259 |

| | | | | | | | | |
|--------------------------|---------------------------------------|------------|---|-----------|----|----------|-----------|--------|
| Copier Lease/Maintenance | Toshiba Financial Service | 1/23/2024 | Copier Lease | 1/31/2024 | \$ | 51.46 | 1/30/2024 | 182326 |
| Copier Lease/Maintenance | Toshiba America Business Solutions | 1/22/2024 | Copier Maintenance | 2/29/2024 | \$ | 9.00 | 2/6/2024 | 182344 |
| Total 01406400002: | | | | | \$ | 127.42 | | |
| 1407150002 | | | | | | | | |
| Life Insurance | North American Benefits Company | 1/22/2024 | Group Term Life Insurance | 1/31/2024 | \$ | 66.00 | 1/30/2024 | 182320 |
| Total 01407150002: | | | | | \$ | 66.00 | | |
| 1407150502 | | | | | | | | |
| Health Benefits | DelCo Public Schools Healthcare Trst | 1/2/2024 | Health Benefits | 1/31/2024 | \$ | 7,778.61 | 1/16/2024 | 182272 |
| Total 01407150502: | | | | | \$ | 7,778.61 | | |
| 1407151002 | | | | | | | | |
| Rx/Dental/Vision/LTD | Express Scripts Inc | 1/2/2024 | Prescription Benefits | 1/31/2024 | \$ | 2.69 | 1/9/2024 | 422 |
| Rx/Dental/Vision/LTD | Express Scripts Inc | 1/12/2024 | Prescription Benefits | 1/31/2024 | \$ | 2.25 | 1/12/2024 | 426 |
| Rx/Dental/Vision/LTD | Express Scripts Inc | 1/22/2024 | Prescription Benefits | 1/31/2024 | \$ | 11.41 | 1/30/2024 | 430 |
| Rx/Dental/Vision/LTD | Express Scripts Inc | 1/2/2024 | Prescription Benefits | 1/31/2024 | \$ | 2.69 | 1/9/2024 | 7092 |
| Rx/Dental/Vision/LTD | Express Scripts Inc | 1/2/2024 | Prescription Benefits | 1/31/2024 | \$ | (2.69) | 1/9/2024 | 7092 |
| Rx/Dental/Vision/LTD | North American Benefits Company | 1/22/2024 | Long Term Civilian Disability Insurance | 2/29/2024 | \$ | 106.04 | 2/6/2024 | 182337 |
| Total 01407151002: | | | | | \$ | 122.39 | | |
| 1407152002 | | | | | | | | |
| Workers Compensation | Arthur J Gallagher Risk Mgmt Serv Inc | 1/8/2024 | 2022 WC Audit | 1/31/2024 | \$ | 210.06 | 1/16/2024 | 182263 |
| Total 01407152002: | | | | | \$ | 210.06 | | |
| 1407200502 | | | | | | | | |
| Computer Expense | Clearnetwork Inc | 12/31/2023 | Spam Management | 1/31/2024 | \$ | 225.06 | 2/12/2024 | 182381 |
| Computer Expense | Clearnetwork Inc | 1/31/2024 | Spam Management | 1/31/2024 | \$ | 227.48 | 2/12/2024 | 182381 |
| Total 01407200502: | | | | | \$ | 452.54 | | |
| 1407300002 | | | | | | | | |
| Communications | Comcast Business | 1/1/2024 | Cable Service | 1/31/2024 | \$ | 61.86 | 1/16/2024 | 182268 |
| Communications | Xtel Communications, Inc | 1/1/2024 | Phone Expense | 1/31/2024 | \$ | 28.14 | 1/16/2024 | 182293 |
| Communications | AT & T Mobility | 1/16/2024 | Cellular Service | 2/29/2024 | \$ | 178.91 | 2/6/2024 | 182331 |
| Total 01407300002: | | | | | \$ | 268.91 | | |
| 1409150002 | | | | | | | | |
| Life Insurance | North American Benefits Company | 1/22/2024 | Group Term Life Insurance | 1/31/2024 | \$ | 53.40 | 1/30/2024 | 182320 |
| Total 01409150002: | | | | | \$ | 53.40 | | |
| 1409150502 | | | | | | | | |
| Health Benefits | DelCo Public Schools Healthcare Trst | 1/2/2024 | Health Benefits | 1/31/2024 | \$ | 6,352.61 | 1/16/2024 | 182272 |
| Total 01409150502: | | | | | \$ | 6,352.61 | | |
| 1409151002 | | | | | | | | |
| Rx/Dental/Vision/LTD | Express Scripts Inc | 1/2/2024 | Prescription Benefits | 1/31/2024 | \$ | 36.13 | 1/9/2024 | 422 |
| Rx/Dental/Vision/LTD | Express Scripts Inc | 1/12/2024 | Prescription Benefits | 1/31/2024 | \$ | 2.61 | 1/12/2024 | 426 |
| Rx/Dental/Vision/LTD | Express Scripts Inc | 1/22/2024 | Prescription Benefits | 1/31/2024 | \$ | 661.77 | 1/30/2024 | 430 |
| Rx/Dental/Vision/LTD | Express Scripts Inc | 1/2/2024 | Prescription Benefits | 1/31/2024 | \$ | 36.13 | 1/9/2024 | 7092 |
| Rx/Dental/Vision/LTD | Express Scripts Inc | 1/2/2024 | Prescription Benefits | 1/31/2024 | \$ | (36.13) | 1/9/2024 | 7092 |
| Rx/Dental/Vision/LTD | North American Benefits Company | 1/22/2024 | Long Term Civilian Disability Insurance | 2/29/2024 | \$ | 122.30 | 2/6/2024 | 182337 |
| Total 01409151002: | | | | | \$ | 822.81 | | |
| 1409152002 | | | | | | | | |
| Workers Compensation | Arthur J Gallagher Risk Mgmt Serv Inc | 1/8/2024 | 2022 WC Audit | 1/31/2024 | \$ | 233.40 | 1/16/2024 | 182263 |
| Total 01409152002: | | | | | \$ | 233.40 | | |
| 1409200002 | | | | | | | | |
| Miscellaneous | Flocco Inc | 8/30/2023 | Work Boots | 1/31/2024 | \$ | 325.00 | 1/16/2024 | 182275 |
| Miscellaneous | Lowe's | 12/6/2023 | (3) Poinsettias | 1/31/2024 | \$ | 28.94 | 1/16/2024 | 182284 |
| Miscellaneous | ReadyRefresh by Nestle Inc | 1/6/2024 | Water Service | 1/31/2024 | \$ | 150.46 | 1/23/2024 | 182306 |
| Miscellaneous | Office Basics, Inc | 12/27/2023 | Break Room Supplies | 1/31/2024 | \$ | 27.67 | 2/12/2024 | 182462 |
| Miscellaneous | Office Basics, Inc | 1/3/2024 | Break Room Supplies | 1/31/2024 | \$ | 98.60 | 2/12/2024 | 182462 |
| Miscellaneous | Office Basics, Inc | 1/19/2024 | Kitchen Supplies | 1/31/2024 | \$ | 37.36 | 2/12/2024 | 182462 |
| Miscellaneous | Office Basics, Inc | 1/24/2024 | Break Room Supplies | 1/31/2024 | \$ | 153.87 | 2/12/2024 | 182462 |
| Miscellaneous | Office Basics, Inc | 1/24/2024 | Office Supplies | 1/31/2024 | \$ | 31.24 | 2/12/2024 | 182462 |
| Total 01409200002: | | | | | \$ | 853.14 | | |
| 1409201302 | | | | | | | | |
| Utilities | Aqua Pennsylvania | 12/20/2023 | 50 Hilltop Rd - Water | 1/31/2024 | \$ | 94.81 | 1/9/2024 | 182244 |
| Utilities | Peco Energy | 12/28/2023 | Allgates Rd Main - Gate Lght | 1/31/2024 | \$ | 36.03 | 1/9/2024 | 182256 |

| | | | | | | | | |
|-------------------------------|--|------------|---|-----------|----|-----------|-----------|--------|
| Utilities | Peco Energy | 12/28/2023 | 1010 Darby Rd | 1/31/2024 | \$ | 3,651.80 | 1/9/2024 | 182256 |
| Utilities | Peco Energy | 12/28/2023 | 1744 Burmont Rd | 1/31/2024 | \$ | 55.71 | 1/9/2024 | 182256 |
| Utilities | Peco Energy | 12/28/2023 | 1002 Darby Rd - Front | 1/31/2024 | \$ | 433.34 | 1/9/2024 | 182256 |
| Utilities | Peco Energy | 12/28/2023 | 3500 Darby Rd - Office | 1/31/2024 | \$ | 106.03 | 1/9/2024 | 182256 |
| Utilities | Peco Energy | 12/28/2023 | 2912 Normandy Rd | 1/31/2024 | \$ | 150.04 | 1/9/2024 | 182256 |
| Utilities | Peco Energy | 12/28/2023 | Brookline Blvd Parking Lot | 1/31/2024 | \$ | 154.93 | 1/9/2024 | 182256 |
| Utilities | Peco Energy | 12/28/2023 | 101 Hilltop Rd | 1/31/2024 | \$ | 3,019.39 | 1/9/2024 | 182256 |
| Utilities | Peco Energy | 1/5/2024 | Natural Gas - 1010 Darby Rd | 1/31/2024 | \$ | 1,204.82 | 1/16/2024 | 182288 |
| Utilities | Aqua Pennsylvania | 1/16/2024 | 1227 E Darby Rd - Brookline - Sprinkler | 1/31/2024 | \$ | 20.97 | 1/23/2024 | 182294 |
| Utilities | Aqua Pennsylvania | 1/16/2024 | 2231 E Darby Rd - Triangle Garden | 1/31/2024 | \$ | 78.29 | 1/23/2024 | 182294 |
| Utilities | Aqua Pennsylvania | 1/16/2024 | 1010 Darby Rd | 1/31/2024 | \$ | 329.87 | 1/23/2024 | 182294 |
| Utilities | Aqua Pennsylvania | 1/17/2024 | 2908 Normandy Rd | 1/31/2024 | \$ | 20.97 | 1/30/2024 | 182311 |
| Utilities | Aqua Pennsylvania | 1/23/2024 | 201 West Chester Pk - Llanerch | 1/31/2024 | \$ | 20.97 | 1/30/2024 | 182311 |
| Utilities | Aqua Pennsylvania | 1/22/2024 | 50 Hilltop Rd - Water | 1/31/2024 | \$ | 113.77 | 1/30/2024 | 182311 |
| Utilities | Constellation NewEnergy Gas Division LLC | 1/25/2024 | Natural Gas - 1010 Darby Rd | 1/31/2024 | \$ | 1,324.81 | 1/30/2024 | 182315 |
| Utilities | Constellation NewEnergy Gas Division LLC | 1/25/2024 | Natural Gas - 2325 Darby Rd | 1/31/2024 | \$ | 304.34 | 1/30/2024 | 182315 |
| Utilities | Constellation NewEnergy Gas Division LLC | 1/25/2024 | Natural Gas - 2912 Normandy Rd | 1/31/2024 | \$ | 94.26 | 1/30/2024 | 182315 |
| Utilities | Peco Energy | 1/29/2024 | Allgates Rd Main - Gate Lght | 2/29/2024 | \$ | 36.95 | 2/6/2024 | 182339 |
| Utilities | Peco Energy | 1/29/2024 | 1010 Darby Rd | 2/29/2024 | \$ | 3,775.50 | 2/6/2024 | 182339 |
| Utilities | Peco Energy | 1/29/2024 | 1744 Burmont Rd | 2/29/2024 | \$ | 55.70 | 2/6/2024 | 182339 |
| Utilities | Peco Energy | 1/29/2024 | 1002 Darby Rd - Front | 2/29/2024 | \$ | 434.78 | 2/6/2024 | 182339 |
| Utilities | Peco Energy | 1/29/2024 | 3500 Darby Rd - Office | 2/29/2024 | \$ | 127.33 | 2/6/2024 | 182339 |
| Utilities | Peco Energy | 1/29/2024 | 2912 Normandy Rd | 2/29/2024 | \$ | 215.30 | 2/6/2024 | 182339 |
| Utilities | Peco Energy | 1/29/2024 | Brookline Blvd Parking Lot | 2/29/2024 | \$ | 170.24 | 2/6/2024 | 182339 |
| Utilities | Peco Energy | 1/29/2024 | 101 Hilltop Rd | 2/29/2024 | \$ | 3,867.17 | 2/6/2024 | 182339 |
| Total 01409201302: | | | | | \$ | 19,898.12 | | |
| 1409290302 | | | | | | | | |
| Professional Services | City Wide Facility Solutions | 11/3/2023 | Janitorial Services - Initial Clean | 2/29/2024 | \$ | 2,000.00 | 2/6/2024 | 182333 |
| Professional Services | City Wide Facility Solutions | 1/1/2024 | Janitorial Services | 1/31/2024 | \$ | 1,881.10 | 2/12/2024 | 182380 |
| Total 01409290302: | | | | | \$ | 3,881.10 | | |
| 1409300002 | | | | | | | | |
| Communications | AT & T Mobility | 1/16/2024 | Cellular Service | 2/29/2024 | \$ | 134.18 | 2/6/2024 | 182331 |
| Total 01409300002: | | | | | \$ | 134.18 | | |
| 1409400802 | | | | | | | | |
| Repairs & Maintenance | Shred Patrol LLC | 1/29/2024 | Township Shredding | 2/29/2024 | \$ | 275.00 | 2/6/2024 | 182342 |
| Repairs & Maintenance | Grainger | 1/8/2024 | 25' Core Reel | 1/31/2024 | \$ | 590.44 | 2/12/2024 | 182413 |
| Repairs & Maintenance | Nichols Plumbing & Heating, Inc | 1/4/2024 | Service - Heat (2325 Darby Rd) | 1/31/2024 | \$ | 200.00 | 2/12/2024 | 182458 |
| Repairs & Maintenance | Sinclair Exterminating Inc | 12/31/2023 | Exterminating - Police/Admin, Public Works | 1/31/2024 | \$ | 360.00 | 2/12/2024 | 182491 |
| Repairs & Maintenance | Tustin Energy Solutions, LLC | 1/15/2024 | Maintenance Agreement - 1010 Darby Rd | 1/31/2024 | \$ | 2,050.00 | 2/12/2024 | 182509 |
| Repairs & Maintenance | Tustin Mechanical Services LLC | 1/11/2024 | Boiler Maintenance Kit | 1/31/2024 | \$ | 2,773.17 | 2/12/2024 | 182510 |
| Total 01409400802: | | | | | \$ | 6,248.61 | | |
| 1409401002 | | | | | | | | |
| Elevator Inspect/Maintenance | Superior Alarm Systems Inc | 1/1/2024 | Fire Alarm Monitoring - Elevator 911 System | 1/31/2024 | \$ | 75.00 | 2/12/2024 | 182498 |
| Total 01409401002: | | | | | \$ | 75.00 | | |
| 1409410902 | | | | | | | | |
| Property & Casualty Insurance | Arthur J Gallagher Risk Mgmt Serv Inc | 12/18/2023 | P & C Insurance Premium â€" 3rd Installment | 1/31/2024 | \$ | 36,377.23 | 1/30/2024 | 182312 |
| Total 01409410902: | | | | | \$ | 36,377.23 | | |
| 1409411702 | | | | | | | | |
| Vehicle Insurance | Arthur J Gallagher Risk Mgmt Serv Inc | 12/18/2023 | P & C Insurance Premium â€" 3rd Installment | 1/31/2024 | \$ | 857.21 | 1/30/2024 | 182312 |
| Total 01409411702: | | | | | \$ | 857.21 | | |
| 1409412802 | | | | | | | | |
| Alarm Maintenance | Superior Alarm Systems Inc | 1/1/2024 | Fire Alarm Monitoring - 1744 Burmont Rd | 1/31/2024 | \$ | 135.00 | 2/12/2024 | 182498 |
| Alarm Maintenance | Superior Alarm Systems Inc | 2/1/2024 | Fire Alarm Monitoring - 2325 Darby Rd | 1/31/2024 | \$ | 135.00 | 2/12/2024 | 182498 |
| Total 01409412802: | | | | | \$ | 270.00 | | |
| 1409510002 | | | | | | | | |
| Vehicle Fuel | Petroleum Traders Corp | 12/27/2023 | Unleaded | 1/31/2024 | \$ | 123.72 | 2/12/2024 | 182473 |
| Vehicle Fuel | Petroleum Traders Corp | 1/19/2024 | Unleaded | 1/31/2024 | \$ | 107.43 | 2/12/2024 | 182473 |
| Total 01409510002: | | | | | \$ | 231.15 | | |
| 1409600002 | | | | | | | | |

| | | | | | | | |
|--------------------------------|--------------------------------------|------------|---|-----------|---------------|-----------|--------|
| Minor Equipment | Imperial Dade | 9/15/2023 | (2) Batteries, Clark Summit Pro 18sq | 1/31/2024 | \$ 2,552.64 | 1/30/2024 | 182318 |
| Minor Equipment | Imperial Dade | 9/29/2023 | Back Pack Vacuum | 1/31/2024 | \$ 406.31 | 1/30/2024 | 182318 |
| Minor Equipment | Imperial Dade | 10/14/2022 | RETURN - Floor Buffer Supplies | 1/31/2024 | \$ (559.72) | 1/30/2024 | 182318 |
| Total 01409600002: | | | | 2,399.23 | | | |
| 1410150002 | | | | | | | |
| Life Insurance | North American Benefits Company | 1/22/2024 | Group Term Life Insurance | 1/31/2024 | \$ 61.80 | 1/30/2024 | 182320 |
| Total 01410150002: | | | | | \$ 61.80 | | |
| 1410150102 | | | | | | | |
| Life Insurance - Police | North American Benefits Company | 1/22/2024 | Group Term Life Insurance | 1/31/2024 | \$ 1,293.75 | 1/30/2024 | 182320 |
| Total 01410150102: | | | | | \$ 1,293.75 | | |
| 1410150202 | | | | | | | |
| Life Insurance - Ret'd Police | North American Benefits Company | 1/22/2024 | Group Term Life Insurance | 1/31/2024 | \$ 608.60 | 1/30/2024 | 182320 |
| Total 01410150202: | | | | | \$ 608.60 | | |
| 1410150502 | | | | | | | |
| Health Benefits | DelCo Public Schools Healthcare Trst | 1/2/2024 | Health Benefits | 1/31/2024 | \$ 11,240.16 | 1/16/2024 | 182272 |
| Total 01410150502: | | | | | \$ 11,240.16 | | |
| 1410150602 | | | | | | | |
| Health Benefits - Police | DelCo Public Schools Healthcare Trst | 1/2/2024 | Health Benefits | 1/31/2024 | \$ 129,182.20 | 1/16/2024 | 182272 |
| Total 01410150602: | | | | | \$ 129,182.20 | | |
| 1410150702 | | | | | | | |
| Health Benefits - Ret'd Police | DelCo Public Schools Healthcare Trst | 1/2/2024 | Health Benefits | 1/31/2024 | \$ 48,973.81 | 1/16/2024 | 182272 |
| Health Benefits - Ret'd Police | Independence Blue Cross | 12/11/2023 | Health Benefits | 1/31/2024 | \$ 4,321.80 | 1/16/2024 | 182276 |
| Health Benefits - Ret'd Police | Independence Blue Cross | 12/11/2023 | Health Benefits | 1/31/2024 | \$ 5,868.27 | 1/16/2024 | 182277 |
| Health Benefits - Ret'd Police | Independence Blue Cross | 12/11/2023 | Health Benefits | 1/31/2024 | \$ 1,658.22 | 1/16/2024 | 182278 |
| Health Benefits - Ret'd Police | Independence Blue Cross | 1/8/2024 | Health Benefits | 1/31/2024 | \$ 5,868.27 | 1/16/2024 | 182279 |
| Health Benefits - Ret'd Police | Independence Blue Cross | 1/8/2024 | Health Benefits | 1/31/2024 | \$ 4,561.90 | 1/16/2024 | 182280 |
| Health Benefits - Ret'd Police | Independence Blue Cross | 1/8/2024 | Health Benefits | 1/31/2024 | \$ 1,658.22 | 1/16/2024 | 182281 |
| Total 01410150702: | | | | | \$ 72,910.49 | | |
| 1410151002 | | | | | | | |
| Rx/Dental/Vision/LTD | Express Scripts Inc | 1/2/2024 | Prescription Benefits | 1/31/2024 | \$ 3,292.15 | 1/9/2024 | 422 |
| Rx/Dental/Vision/LTD | Express Scripts Inc | 1/12/2024 | Prescription Benefits | 1/31/2024 | \$ 334.37 | 1/12/2024 | 426 |
| Rx/Dental/Vision/LTD | Express Scripts Inc | 1/22/2024 | Prescription Benefits | 1/31/2024 | \$ 37.22 | 1/30/2024 | 430 |
| Rx/Dental/Vision/LTD | Express Scripts Inc | 1/2/2024 | Prescription Benefits | 1/31/2024 | \$ 3,292.15 | 1/9/2024 | 7092 |
| Rx/Dental/Vision/LTD | Express Scripts Inc | 1/2/2024 | Prescription Benefits | 1/31/2024 | \$ (3,292.15) | 1/9/2024 | 7092 |
| Rx/Dental/Vision/LTD | Vision Benefits of America | 1/5/2024 | Vision Benefits | 1/31/2024 | \$ 50.00 | 1/23/2024 | 182309 |
| Rx/Dental/Vision/LTD | North American Benefits Company | 1/22/2024 | Long Term Civilian Disability Insurance | 2/29/2024 | \$ 133.92 | 2/6/2024 | 182337 |
| Total 01410151002: | | | | | \$ 3,847.66 | | |
| 1410151102 | | | | | | | |
| Rx/Dental/Vision/LTD - Police | Express Scripts Inc | 1/2/2024 | Prescription Benefits | 1/31/2024 | \$ 8,336.01 | 1/9/2024 | 422 |
| Rx/Dental/Vision/LTD - Police | Express Scripts Inc | 1/12/2024 | Prescription Benefits | 1/31/2024 | \$ 442.60 | 1/12/2024 | 426 |
| Rx/Dental/Vision/LTD - Police | Express Scripts Inc | 1/22/2024 | Prescription Benefits | 1/31/2024 | \$ 7,972.49 | 1/30/2024 | 430 |
| Rx/Dental/Vision/LTD - Police | Express Scripts Inc | 1/2/2024 | Prescription Benefits | 1/31/2024 | \$ 8,336.01 | 1/9/2024 | 7092 |
| Rx/Dental/Vision/LTD - Police | Express Scripts Inc | 1/2/2024 | Prescription Benefits | 1/31/2024 | \$ (8,336.01) | 1/9/2024 | 7092 |
| Rx/Dental/Vision/LTD - Police | Vision Benefits of America | 1/5/2024 | Vision Benefits | 1/31/2024 | \$ 100.00 | 1/30/2024 | 182328 |
| Total 01410151102: | | | | | \$ 16,851.10 | | |
| 1410151202 | | | | | | | |
| Rx/Dent'l/Vision - Retd Police | Express Scripts Inc | 1/2/2024 | Prescription Benefits | 1/31/2024 | \$ 83.01 | 1/9/2024 | 422 |
| Rx/Dent'l/Vision - Retd Police | Express Scripts Inc | 1/2/2024 | Prescription Benefits | 1/31/2024 | \$ 11,043.89 | 1/9/2024 | 422 |
| Rx/Dent'l/Vision - Retd Police | Express Scripts Inc | 1/2/2024 | Prescription Benefits | 1/31/2024 | \$ 5,280.54 | 1/9/2024 | 422 |
| Rx/Dent'l/Vision - Retd Police | Express Scripts Inc | 1/12/2024 | Prescription Benefits | 1/31/2024 | \$ 149.42 | 1/12/2024 | 426 |
| Rx/Dent'l/Vision - Retd Police | Express Scripts Inc | 1/12/2024 | Prescription Benefits | 1/31/2024 | \$ 16,510.10 | 1/12/2024 | 426 |
| Rx/Dent'l/Vision - Retd Police | Express Scripts Inc | 1/12/2024 | Prescription Benefits | 1/31/2024 | \$ 20,138.55 | 1/12/2024 | 426 |
| Rx/Dent'l/Vision - Retd Police | Express Scripts Inc | 1/22/2024 | Prescription Benefits | 1/31/2024 | \$ 200.87 | 1/30/2024 | 430 |
| Rx/Dent'l/Vision - Retd Police | Express Scripts Inc | 1/22/2024 | Prescription Benefits | 1/31/2024 | \$ 8,315.12 | 1/30/2024 | 430 |
| Rx/Dent'l/Vision - Retd Police | Express Scripts Inc | 1/22/2024 | Prescription Benefits | 1/31/2024 | \$ 4,350.27 | 1/30/2024 | 430 |
| Rx/Dent'l/Vision - Retd Police | Express Scripts Inc | 1/2/2024 | Prescription Benefits | 1/31/2024 | \$ 83.01 | 1/9/2024 | 7092 |
| Rx/Dent'l/Vision - Retd Police | Express Scripts Inc | 1/2/2024 | Prescription Benefits | 1/31/2024 | \$ 11,043.89 | 1/9/2024 | 7092 |
| Rx/Dent'l/Vision - Retd Police | Express Scripts Inc | 1/2/2024 | Prescription Benefits | 1/31/2024 | \$ 5,280.54 | 1/9/2024 | 7092 |
| Rx/Dent'l/Vision - Retd Police | Express Scripts Inc | 1/2/2024 | Prescription Benefits | 1/31/2024 | \$ (83.01) | 1/9/2024 | 7092 |

| | | | | | | | | |
|-------------------------------|---|------------|---|-----------|----|-------------|-----------|--------|
| Rx/Dent/IVision - Retd Police | Express Scripts Inc | 1/2/2024 | Prescription Benefits | 1/31/2024 | \$ | (11,043.89) | 1/9/2024 | 7092 |
| Rx/Dent/IVision - Retd Police | Express Scripts Inc | 1/2/2024 | Prescription Benefits | 1/31/2024 | \$ | (5,280.54) | 1/9/2024 | 7092 |
| Rx/Dent/IVision - Retd Police | Vision Benefits of America | 1/5/2024 | Vision Benefits | 1/31/2024 | \$ | 268.00 | 1/23/2024 | 182309 |
| Total 01410151202: | | | | | \$ | 66,339.77 | | |
| 1410152002 | | | | | | | | |
| Workers Compensation | Arthur J Gallagher Risk Mgmt Serv Inc | 1/8/2024 | 2022 WC Audit | 1/31/2024 | \$ | 5,508.24 | 1/16/2024 | 182263 |
| Workers Compensation | Arthur J Gallagher Risk Mgmt Serv Inc | 1/8/2024 | Heart & Lung | 1/31/2024 | \$ | 14,442.00 | 1/16/2024 | 182263 |
| Total 01410152002: | | | | | \$ | 19,950.24 | | |
| 1410152502 | | | | | | | | |
| Death Service Benefits | Gail Stickney | 2/1/2024 | Death Service Benefits | 1/31/2024 | \$ | 157.26 | 2/12/2024 | 182409 |
| Total 01410152502: | | | | | \$ | 157.26 | | |
| 1410200002 | | | | | | | | |
| Miscellaneous Expense | ReadyRefresh by Nestle Inc | 1/6/2024 | Water Service | 1/31/2024 | \$ | 150.45 | 1/23/2024 | 182306 |
| Miscellaneous Expense | Petty Cash - Haverford Township | 1/31/2024 | Petty Cash - Police | 2/29/2024 | \$ | 67.28 | 2/6/2024 | 182341 |
| Miscellaneous Expense | R.S. Sales & Service, Inc | 1/31/2024 | Service - Ice Machine | 1/31/2024 | \$ | 576.00 | 2/12/2024 | 182481 |
| Miscellaneous Expense | St Jude Shop Inc | 1/2/2024 | St Joseph Personal Size | 1/31/2024 | \$ | 43.00 | 2/12/2024 | 182495 |
| Miscellaneous Expense | ULINE, Inc | 12/18/2023 | (2) Cotton Coveralls | 1/31/2024 | \$ | 105.37 | 2/12/2024 | 182512 |
| Total 01410200002: | | | | | \$ | 942.10 | | |
| 1410200202 | | | | | | | | |
| Office Supplies | Office Basics, Inc | 11/20/2023 | Office Supplies | 1/31/2024 | \$ | 329.94 | 1/23/2024 | 182304 |
| Office Supplies | Office Basics, Inc | 1/10/2024 | RETURN - (6) Ink Cartridges | 1/31/2024 | \$ | (341.46) | 2/12/2024 | 182462 |
| Office Supplies | Office Basics, Inc | 1/3/2024 | Office Supplies | 1/31/2024 | \$ | 350.43 | 2/12/2024 | 182462 |
| Office Supplies | Office Basics, Inc | 1/9/2024 | Office Supplies | 1/31/2024 | \$ | 682.92 | 2/12/2024 | 182462 |
| Office Supplies | Office Basics, Inc | 1/10/2024 | Office Supplies | 1/31/2024 | \$ | 316.62 | 2/12/2024 | 182462 |
| Office Supplies | Office Basics, Inc | 1/11/2024 | Office Supplies | 1/31/2024 | \$ | 64.47 | 2/12/2024 | 182462 |
| Office Supplies | Office Basics, Inc | 1/12/2024 | Office Supplies | 1/31/2024 | \$ | 83.96 | 2/12/2024 | 182462 |
| Office Supplies | Office Basics, Inc | 1/29/2024 | Office Supplies | 1/31/2024 | \$ | 112.06 | 2/12/2024 | 182462 |
| Office Supplies | Schwaab Inc | 1/4/2024 | Flash Stamp | 1/31/2024 | \$ | 52.50 | 2/12/2024 | 182489 |
| Office Supplies | Schwaab Inc | 1/10/2024 | 2024 Self-Inking Date Stamp | 1/31/2024 | \$ | 170.49 | 2/12/2024 | 182489 |
| Total 01410200202: | | | | | \$ | 1,821.93 | | |
| 1410200302 | | | | | | | | |
| Office Equip & Furniture | Deborah Tori | 1/6/2024 | Reimb - Prisoner Property Bags | 1/31/2024 | \$ | 56.62 | 1/16/2024 | 182270 |
| Total 01410200302: | | | | | \$ | 56.62 | | |
| 1410210102 | | | | | | | | |
| Postage Expense | FP Finance Program | 12/27/2023 | Postage Meter Lease | 1/31/2024 | \$ | 18.75 | 1/9/2024 | 182250 |
| Postage Expense | Federal Express Corp | 1/23/2024 | Express Mail | 2/29/2024 | \$ | 52.15 | 2/6/2024 | 182334 |
| Postage Expense | FP Finance Program | 1/29/2024 | Postage Meter Lease | 2/29/2024 | \$ | 18.75 | 2/6/2024 | 182335 |
| Total 01410210102: | | | | | \$ | 89.65 | | |
| 1410260002 | | | | | | | | |
| Assoc Dues & Membership | FBI-LEEDA | 1/1/2024 | FBI LEEDA Membership - J Kelly | 1/31/2024 | \$ | 50.00 | 2/12/2024 | 182403 |
| Assoc Dues & Membership | FBI-LEEDA | 1/1/2024 | FBI LEEDA Membership - E Dolan | 1/31/2024 | \$ | 50.00 | 2/12/2024 | 182403 |
| Assoc Dues & Membership | IACP | 12/20/2023 | Membership - E Dolan | 1/31/2024 | \$ | 190.00 | 2/12/2024 | 182425 |
| Assoc Dues & Membership | IACP | 12/20/2023 | Membership - J Viola | 1/31/2024 | \$ | 190.00 | 2/12/2024 | 182425 |
| Assoc Dues & Membership | IACP | 12/20/2023 | Membership - S Bedrossian | 1/31/2024 | \$ | 190.00 | 2/12/2024 | 182425 |
| Assoc Dues & Membership | IACP | 12/20/2023 | Membership - J Hagan | 1/31/2024 | \$ | 190.00 | 2/12/2024 | 182425 |
| Assoc Dues & Membership | IACP | 12/20/2023 | Membership - T Long | 1/31/2024 | \$ | 190.00 | 2/12/2024 | 182425 |
| Assoc Dues & Membership | National Tactical Officers Association | 1/16/2024 | Membership Renewal - C Scott #96175 | 1/31/2024 | \$ | 35.00 | 2/12/2024 | 182457 |
| Assoc Dues & Membership | Police Chiefs Assoc. of Southeastern Pa | 1/25/2024 | 2024 Membership Dues - J Viola | 1/31/2024 | \$ | 75.00 | 2/12/2024 | 182477 |
| Total 01410260002: | | | | | \$ | 1,160.00 | | |
| 1410260102 | | | | | | | | |
| Publications & Subscriptions | Thomson Reuters-West | 1/1/2024 | Information Charges | 1/31/2024 | \$ | 316.33 | 2/12/2024 | 182502 |
| Total 01410260102: | | | | | \$ | 316.33 | | |
| 1410260202 | | | | | | | | |
| Training | Delaware Cty Police Chief's Association | 1/5/2024 | DCPCA Installation Banquet | 1/31/2024 | \$ | 375.00 | 1/9/2024 | 182249 |
| Training | Delaware County Fraternal Order of | 1/5/2024 | Award and Retirement Dinner | 1/31/2024 | \$ | 180.00 | 1/16/2024 | 182271 |
| Training | Delaware County Fraternal Order of | 1/5/2024 | Award and Retirement Dinner | 1/31/2024 | \$ | (180.00) | 1/22/2024 | 182271 |
| Training | Baltimore County Police Foundation Inc | 1/23/2024 | Training - SBedrossian, TLong, AHughes, THowe | 1/31/2024 | \$ | 1,100.00 | 2/12/2024 | 182363 |
| Training | CooperUniversity Physicians | 1/30/2024 | Training - S Lane, L Howard | 1/31/2024 | \$ | 350.00 | 2/12/2024 | 182383 |
| Training | PA Chiefs of Police Association | 1/11/2024 | Training - S Bedrossian | 1/31/2024 | \$ | 150.00 | 2/12/2024 | 182465 |

| | | | | | | | | |
|-------------------------------|---------------------------------------|------------|---|-----------|----|-----------|-----------|--------|
| Training | PA Chiefs of Police Association | 1/11/2024 | Training - G Dolan | 1/31/2024 | \$ | 150.00 | 2/12/2024 | 182465 |
| Training | Personal Protection Consultants inc | 1/24/2024 | Training - SLane, MDeSanctis | 1/31/2024 | \$ | 1,794.00 | 2/12/2024 | 182471 |
| Total 01410260202: | | | | | \$ | 3,919.00 | | |
| 1410280302 | | | | | | | | |
| Uniforms | 911 Safety Equipment LLC | 1/30/2024 | Uniforms | 1/31/2024 | \$ | 150.00 | 2/12/2024 | 182347 |
| Uniforms | Atlantic Tactical | 1/4/2024 | Uniform | 1/31/2024 | \$ | 41.99 | 2/12/2024 | 182362 |
| Uniforms | Emblem Enterprises, Inc | 1/24/2024 | Uniforms | 1/31/2024 | \$ | 2,685.01 | 2/12/2024 | 182402 |
| Uniforms | Witmer Public Safety Group Inc | 1/2/2024 | Uniforms | 1/31/2024 | \$ | 16.00 | 2/12/2024 | 182517 |
| Uniforms | Witmer Public Safety Group Inc | 1/2/2024 | Uniforms | 1/31/2024 | \$ | 108.00 | 2/12/2024 | 182517 |
| Uniforms | Witmer Public Safety Group Inc | 1/2/2024 | Uniforms | 1/31/2024 | \$ | 138.00 | 2/12/2024 | 182517 |
| Uniforms | Witmer Public Safety Group Inc | 1/2/2024 | Uniforms | 1/31/2024 | \$ | 33.00 | 2/12/2024 | 182517 |
| Uniforms | Witmer Public Safety Group Inc | 1/2/2024 | Uniforms | 1/31/2024 | \$ | 26.00 | 2/12/2024 | 182517 |
| Uniforms | Witmer Public Safety Group Inc | 1/2/2024 | Uniforms | 1/31/2024 | \$ | 61.00 | 2/12/2024 | 182517 |
| Uniforms | Witmer Public Safety Group Inc | 1/12/2024 | Uniforms | 1/31/2024 | \$ | 25.00 | 2/12/2024 | 182517 |
| Uniforms | Witmer Public Safety Group Inc | 1/23/2024 | Uniforms | 1/31/2024 | \$ | 138.00 | 2/12/2024 | 182517 |
| Total 01410280302: | | | | | \$ | 3,422.00 | | |
| 1410280702 | | | | | | | | |
| Uniform Maintenance | Manoa Cleaners, Inc | 12/16/2023 | Uniform cleaning | 1/31/2024 | \$ | 946.35 | 2/12/2024 | 182445 |
| Total 01410280702: | | | | | \$ | 946.35 | | |
| 1410300002 | | | | | | | | |
| Communications | Comcast Business | 1/1/2024 | Cable Service | 1/31/2024 | \$ | 1,162.40 | 1/16/2024 | 182268 |
| Communications | Xtel Communications, Inc | 1/1/2024 | Phone Expense | 1/31/2024 | \$ | 528.71 | 1/16/2024 | 182293 |
| Communications | Comcast | 1/12/2024 | Cable Service - 1010 Darby Rd | 1/31/2024 | \$ | 153.66 | 1/23/2024 | 182298 |
| Communications | AT & T Mobility | 1/16/2024 | Cellular Service | 2/29/2024 | \$ | 2,907.33 | 2/6/2024 | 182331 |
| Total 01410300002: | | | | | \$ | 4,752.10 | | |
| 1410300102 | | | | | | | | |
| Radio Rent/Maintenance | Eagle Wireless Communications LLC | 1/15/2024 | Geotab Monthly Service - Police | 1/31/2024 | \$ | 568.62 | 2/12/2024 | 182397 |
| Total 01410300102: | | | | | \$ | 568.62 | | |
| 1410400002 | | | | | | | | |
| Copier Lease/Maintenance | Toshiba America Business Solutions | 12/25/2023 | Copier Maintenance | 1/31/2024 | \$ | 153.39 | 1/9/2024 | 182258 |
| Copier Lease/Maintenance | Toshiba Financial Service | 12/28/2023 | Copier Lease | 1/31/2024 | \$ | 549.11 | 1/9/2024 | 182259 |
| Copier Lease/Maintenance | Toshiba Financial Service | 1/23/2024 | Copier Lease | 1/31/2024 | \$ | 549.11 | 1/30/2024 | 182326 |
| Copier Lease/Maintenance | Toshiba America Business Solutions | 1/22/2024 | Copier Maintenance | 2/29/2024 | \$ | 118.74 | 2/6/2024 | 182344 |
| Total 01410400002: | | | | | \$ | 1,370.35 | | |
| 1410411702 | | | | | | | | |
| Vehicle Insurance | Arthur J Gallagher Risk Mgmt Serv Inc | 12/18/2023 | P & C Insurance Premium â€“ 3rd Installment | 1/31/2024 | \$ | 18,458.68 | 1/30/2024 | 182312 |
| Total 01410411702: | | | | | \$ | 18,458.68 | | |
| 1410412402 | | | | | | | | |
| Police Professional Insurance | Arthur J Gallagher Risk Mgmt Serv Inc | 12/18/2023 | P & C Insurance Premium â€“ 3rd Installment | 1/31/2024 | \$ | 14,737.45 | 1/30/2024 | 182312 |
| Total 01410412402: | | | | | \$ | 14,737.45 | | |
| 1410510002 | | | | | | | | |
| Vehicle Fuel | PA DEP | 12/5/2023 | Storage Tank Permit - 1014 Darby Rd | 1/31/2024 | \$ | 50.00 | 1/30/2024 | 182321 |
| Vehicle Fuel | Petroleum Traders Corp | 12/27/2023 | Unleaded | 1/31/2024 | \$ | 7,576.44 | 2/12/2024 | 182473 |
| Vehicle Fuel | Petroleum Traders Corp | 1/19/2024 | Unleaded | 1/31/2024 | \$ | 8,189.08 | 2/12/2024 | 182473 |
| Vehicle Fuel | School District of Haverford Township | 1/29/2024 | Diesel Fuel | 1/31/2024 | \$ | 81.90 | 2/12/2024 | 182488 |
| Total 01410510002: | | | | | \$ | 15,897.42 | | |
| 1410510702 | | | | | | | | |
| Vehicle Maintenance | Ardmore Tire Inc | 12/20/2023 | (16) Tires C-10, 12, 16, 18 | 1/31/2024 | \$ | 2,280.16 | 2/12/2024 | 182359 |
| Vehicle Maintenance | Berrodin Parts Warehouse | 1/9/2024 | (3) Coils, (20) Bulbs C-42 | 1/31/2024 | \$ | 222.82 | 2/12/2024 | 182364 |
| Vehicle Maintenance | Berrodin Parts Warehouse | 1/9/2024 | (4) Capsules C-31 | 1/31/2024 | \$ | 15.84 | 2/12/2024 | 182364 |
| Vehicle Maintenance | Berrodin Parts Warehouse | 1/9/2024 | Sensor C-12 | 1/31/2024 | \$ | 44.14 | 2/12/2024 | 182364 |
| Vehicle Maintenance | Berrodin Parts Warehouse | 1/17/2024 | Housing C-16 | 1/31/2024 | \$ | 48.50 | 2/12/2024 | 182364 |
| Vehicle Maintenance | Berrodin Parts Warehouse | 1/18/2024 | Temp Sensor C-16 | 1/31/2024 | \$ | 17.09 | 2/12/2024 | 182364 |
| Vehicle Maintenance | Berrodin Parts Warehouse | 1/26/2024 | Temp Sensor C-21 | 1/31/2024 | \$ | 17.09 | 2/12/2024 | 182364 |
| Vehicle Maintenance | Church's Auto Parts | 1/17/2024 | Battery, Core C-31 | 1/31/2024 | \$ | 214.05 | 2/12/2024 | 182379 |
| Vehicle Maintenance | Church's Auto Parts | 1/18/2024 | RETURN - Core | 1/31/2024 | \$ | (9.00) | 2/12/2024 | 182379 |
| Vehicle Maintenance | Havis Inc | 12/21/2022 | iPad | 1/31/2024 | \$ | 829.76 | 2/12/2024 | 182418 |
| Vehicle Maintenance | Hill Buick GMC | 1/5/2024 | Pump C-21 | 1/31/2024 | \$ | 384.96 | 2/12/2024 | 182420 |
| Vehicle Maintenance | Hill Buick GMC | 12/14/2023 | Sensor, Connector and Motor, C-12, 25 | 1/31/2024 | \$ | 143.04 | 2/12/2024 | 182420 |

| | | | | | | | |
|--------------------------|--------------------------------|------------|---|-----------|---------------|-----------|--------|
| Vehicle Maintenance | Hill Buick GMC | 12/11/2023 | Link C-28 | 1/31/2024 | \$ 59.99 | 2/12/2024 | 182420 |
| Vehicle Maintenance | Hill Buick GMC | 12/22/2023 | (3) Pad Kits C-14, 16, 22 | 1/31/2024 | \$ 371.25 | 2/12/2024 | 182420 |
| Vehicle Maintenance | Hill Buick GMC | 12/14/2023 | 2 Pad Kits, C-41,15 | 1/31/2024 | \$ 153.69 | 2/12/2024 | 182420 |
| Vehicle Maintenance | Hill Buick GMC | 12/18/2023 | Arm C-16 | 1/31/2024 | \$ 194.43 | 2/12/2024 | 182420 |
| Vehicle Maintenance | Hill Buick GMC | 1/22/2024 | Lamp, C-2 | 1/31/2024 | \$ 471.08 | 2/12/2024 | 182420 |
| Vehicle Maintenance | Hill Buick GMC | 12/27/2023 | Pump, Belt, Belt Kit C-14 | 1/31/2024 | \$ 364.85 | 2/12/2024 | 182420 |
| Vehicle Maintenance | Hill Buick GMC | 12/22/2023 | Module C-15 | 1/31/2024 | \$ 121.42 | 2/12/2024 | 182420 |
| Vehicle Maintenance | Hill Buick GMC | 12/28/2023 | 94R-AGM, (6) Nut, Clamp, Hose | 1/31/2024 | \$ 509.65 | 2/12/2024 | 182420 |
| Vehicle Maintenance | Hill Buick GMC | 1/4/2024 | (12) Filters C-12, 14, 17, 19, 24, 35 | 1/31/2024 | \$ 87.60 | 2/12/2024 | 182420 |
| Vehicle Maintenance | Hill Buick GMC | 1/8/2024 | (2) Sensors C-21 | 1/31/2024 | \$ 125.60 | 2/12/2024 | 182420 |
| Vehicle Maintenance | Hill Buick GMC | 1/12/2024 | (2) Relays C-16, 27, 29 | 1/31/2024 | \$ 248.64 | 2/12/2024 | 182420 |
| Vehicle Maintenance | Hill Buick GMC | 1/15/2024 | Reman Eng, Core C-25 | 1/31/2024 | \$ 11,111.00 | 2/12/2024 | 182420 |
| Vehicle Maintenance | Hill Buick GMC | 1/24/2024 | (12) Filters C-1, 2,4 ,10,11, 28 | 1/31/2024 | \$ 87.60 | 2/12/2024 | 182420 |
| Vehicle Maintenance | Hill Buick GMC | 1/26/2024 | Tank C-11 | 1/31/2024 | \$ 33.27 | 2/12/2024 | 182420 |
| Vehicle Maintenance | Hill Buick GMC | 1/26/2024 | RETURN - Core | 1/31/2024 | \$ (5,000.00) | 2/12/2024 | 182420 |
| Vehicle Maintenance | Joe's Automotive | 12/20/2023 | Alignment - C-16 | 1/31/2024 | \$ 120.00 | 2/12/2024 | 182431 |
| Vehicle Maintenance | McLenaghan Wholesale Tires Inc | 1/11/2024 | (7) Tires C-4, 23 | 1/31/2024 | \$ 1,391.00 | 2/12/2024 | 182450 |
| Vehicle Maintenance | Pacifico Marple Ford | 1/4/2024 | (2) Blades, (6) Filter C-6, 7, 20 | 1/31/2024 | \$ 134.64 | 2/12/2024 | 182466 |
| Vehicle Maintenance | Pacifico Marple Ford | 1/5/2024 | Tube C-44 | 1/31/2024 | \$ 26.50 | 2/12/2024 | 182466 |
| Vehicle Maintenance | Park's Best Car Wash Inc | 1/2/2024 | Car Washes | 1/31/2024 | \$ 442.50 | 2/12/2024 | 182467 |
| Vehicle Maintenance | TruckPro LLC Corp | 12/20/2023 | (2) Batteries, C-27 | 1/31/2024 | \$ 332.16 | 2/12/2024 | 182507 |
| Vehicle Maintenance | TruckPro LLC Corp | 1/16/2024 | (2) Batteries C-26, 41 | 1/31/2024 | \$ 341.50 | 2/12/2024 | 182507 |
| Vehicle Maintenance | YCG Inc | 1/29/2024 | ENRADD Calibrations | 1/31/2024 | \$ 3,341.75 | 2/12/2024 | 182518 |
| Total 01410510702: | | | | | \$ 19,278.57 | | |
| 1410600002 | | | | | | | |
| Minor Equipment | Qualification Targets Inc | 1/25/2024 | (350) Silhouette Targets | 1/31/2024 | \$ 450.84 | 2/12/2024 | 182480 |
| Minor Equipment | Tedder Industries LLC | 1/22/2024 | (8) Holsters, (8) Rapid Force Belts | 1/31/2024 | \$ 863.55 | 2/12/2024 | 182501 |
| Minor Equipment | Witmer Public Safety Group Inc | 1/11/2024 | (5) Air Respirator Kits | 1/31/2024 | \$ 3,683.11 | 2/12/2024 | 182517 |
| Total 01410600002: | | | | | \$ 4,997.50 | | |
| 1410610302 | | | | | | | |
| Weapons/Ammunition/Range | MMJM Enterprises LLC | 1/4/2024 | Ammunition | 1/31/2024 | \$ 231.40 | 2/12/2024 | 182455 |
| Weapons/Ammunition/Range | MMJM Enterprises LLC | 1/24/2024 | Ammunition | 1/31/2024 | \$ 958.20 | 2/12/2024 | 182455 |
| Total 01410610302: | | | | | \$ 1,189.60 | | |
| 1410610802 | | | | | | | |
| Drug Testing | Drugscan, Inc | 12/21/2023 | Drug testing | 1/31/2024 | \$ 705.00 | 2/12/2024 | 182395 |
| Total 01410610802: | | | | | \$ 705.00 | | |
| 1410611502 | | | | | | | |
| Auto Purchase Expense | Havis Inc | 9/25/2023 | Outfit C-19 | 1/31/2024 | \$ 20,213.67 | 2/12/2024 | 182418 |
| Auto Purchase Expense | Havis Inc | 10/20/2023 | Outfit C-17 | 1/31/2024 | \$ 19,445.67 | 2/12/2024 | 182418 |
| Total 01410611502: | | | | | \$ 39,659.34 | | |
| 1410612202 | | | | | | | |
| Printing Expenses | Nuss Printing Inc | 1/17/2024 | Business Cards - MHufnal, SRost, CHines | 1/31/2024 | \$ 173.50 | 2/12/2024 | 182461 |
| Total 01410612202: | | | | | \$ 173.50 | | |
| 1410612502 | | | | | | | |
| Live Scan Maintenance | All Traffic Solutions, Inc. | 1/4/2024 | Traffic App Suite (12 mos) | 1/31/2024 | \$ 5,500.00 | 2/12/2024 | 182353 |
| Total 01410612502: | | | | | \$ 5,500.00 | | |
| 1410614102 | | | | | | | |
| Canine Development | PetSmart #1804 | 1/17/2024 | K9 Supplies - Axel | 1/31/2024 | \$ 155.97 | 2/12/2024 | 182474 |
| Canine Development | Tri County Canine, LLC | 1/12/2024 | Seminar - TMcDermott, LMLaughlin | 1/31/2024 | \$ 150.00 | 2/12/2024 | 182503 |
| Canine Development | VCA Wellington Animal Hospital | 12/10/2023 | Boarding - Bodhi | 1/31/2024 | \$ 357.30 | 2/12/2024 | 182513 |
| Total 01410614102: | | | | | \$ 663.27 | | |
| 1410614202 | | | | | | | |
| Community Service | Human Relations Media | 1/10/2024 | (3) Training DVD's | 1/31/2024 | \$ 481.43 | 2/12/2024 | 182424 |
| Total 01410614202: | | | | | \$ 481.43 | | |
| 1411201602 | | | | | | | |
| Hydrant Rentals | Aqua Pennsylvania | 12/20/2023 | 50 Hilltop Rd - Hydrant | 1/31/2024 | \$ 62.26 | 1/9/2024 | 182244 |
| Hydrant Rentals | Aqua Pennsylvania | 1/2/2024 | (519) Hydrants - 2325 Darby Rd | 1/31/2024 | \$ 44,385.63 | 1/16/2024 | 182262 |
| Hydrant Rentals | Aqua Pennsylvania | 1/2/2024 | (2) Hydrants - 120 Allgates Dr | 1/31/2024 | \$ 207.24 | 1/16/2024 | 182262 |
| Hydrant Rentals | Aqua Pennsylvania | 1/2/2024 | (25) Hydrants - 2325 Darby Rd | 1/31/2024 | \$ 2,138.04 | 1/16/2024 | 182262 |

| | | | | | | | | |
|-------------------------|---------------------------------------|------------|--|-----------|----|-----------|-----------|--------|
| Hydrant Rentals | Aqua Pennsylvania | 1/16/2024 | 1010 Darby Rd - Hydrant | 1/31/2024 | \$ | 248.86 | 1/23/2024 | 182294 |
| Hydrant Rentals | Aqua Pennsylvania | 1/17/2024 | 1 Allgates Dr - Hydrant | 1/31/2024 | \$ | 20.97 | 1/30/2024 | 182311 |
| Hydrant Rentals | Aqua Pennsylvania | 1/17/2024 | 900 Parkview Dr - Hydrant | 1/31/2024 | \$ | 112.98 | 1/30/2024 | 182311 |
| Hydrant Rentals | Aqua Pennsylvania | 1/22/2024 | 50 Hilltop Rd - Hydrant | 1/31/2024 | \$ | 41.62 | 1/30/2024 | 182311 |
| Total 01411201602: | | | | | \$ | 47,217.60 | | |
| 1411260302 | | | | | | | | |
| Recruitment & Retention | Robert Sandy | 12/27/2023 | Act 172 (2023 Refund) | 1/31/2024 | \$ | 254.41 | 1/9/2024 | 182257 |
| Recruitment & Retention | Andrew Payne | 1/22/2024 | Reimb - HTBF Awards | 2/29/2024 | \$ | 45.00 | 2/6/2024 | 182329 |
| Recruitment & Retention | Park's Best Car Wash Inc | 1/2/2024 | Car Washes | 1/31/2024 | \$ | 52.50 | 2/12/2024 | 182467 |
| Total 01411260302: | | | | | \$ | 351.91 | | |
| 1411300002 | | | | | | | | |
| Communications | Oakmont Fire Company | 1/5/2024 | Reimb - Active 911 | 1/31/2024 | \$ | 742.50 | 1/16/2024 | 182287 |
| Total 01411300002: | | | | | \$ | 742.50 | | |
| 1411411902 | | | | | | | | |
| Fire Truck Insurance | Arthur J Gallagher Risk Mgmt Serv Inc | 12/18/2023 | P & C Insurance Premium a€" 3rd Installment | 1/31/2024 | \$ | 4,628.95 | 1/30/2024 | 182312 |
| Total 01411411902: | | | | | \$ | 4,628.95 | | |
| 1411510002 | | | | | | | | |
| Vehicle Fuel | Petroleum Traders Corp | 12/27/2023 | Unleaded | 1/31/2024 | \$ | 314.93 | 2/12/2024 | 182473 |
| Vehicle Fuel | Petroleum Traders Corp | 1/19/2024 | Unleaded | 1/31/2024 | \$ | 273.47 | 2/12/2024 | 182473 |
| Vehicle Fuel | School District of Haverford Township | 1/29/2024 | Diesel Fuel | 1/31/2024 | \$ | 1,493.51 | 2/12/2024 | 182488 |
| Total 01411510002: | | | | | \$ | 2,081.91 | | |
| 1411510702 | | | | | | | | |
| Vehicle Maintenance | Del-Val International Trucks, Inc | 1/2/2024 | Turbo Charge Actuator, Turbo Charge Actuator Core E-56 | 1/31/2024 | \$ | 1,800.98 | 2/12/2024 | 182392 |
| Total 01411510702: | | | | | \$ | 1,800.98 | | |
| 1412150002 | | | | | | | | |
| Life Insurance | North American Benefits Company | 1/22/2024 | Group Term Life Insurance | 1/31/2024 | \$ | 37.80 | 1/30/2024 | 182320 |
| Total 01412150002: | | | | | \$ | 37.80 | | |
| 1412150502 | | | | | | | | |
| Health Benefits | DelCo Public Schools Healthcare Trst | 1/2/2024 | Health Benefits | 1/31/2024 | \$ | 4,213.64 | 1/16/2024 | 182272 |
| Total 01412150502: | | | | | \$ | 4,213.64 | | |
| 1412151002 | | | | | | | | |
| Rx/Dental/Vision/LTD | Express Scripts Inc | 1/2/2024 | Prescription Benefits | 1/31/2024 | \$ | 27.44 | 1/9/2024 | 422 |
| Rx/Dental/Vision/LTD | Express Scripts Inc | 1/12/2024 | Prescription Benefits | 1/31/2024 | \$ | (3.18) | 1/12/2024 | 426 |
| Rx/Dental/Vision/LTD | Express Scripts Inc | 1/22/2024 | Prescription Benefits | 1/31/2024 | \$ | 176.86 | 1/30/2024 | 430 |
| Rx/Dental/Vision/LTD | Express Scripts Inc | 1/2/2024 | Prescription Benefits | 1/31/2024 | \$ | 27.44 | 1/9/2024 | 7092 |
| Rx/Dental/Vision/LTD | Express Scripts Inc | 1/2/2024 | Prescription Benefits | 1/31/2024 | \$ | (27.44) | 1/9/2024 | 7092 |
| Rx/Dental/Vision/LTD | North American Benefits Company | 1/22/2024 | Long Term Civilian Disability Insurance | 2/29/2024 | \$ | 80.77 | 2/6/2024 | 182337 |
| Total 01412151002: | | | | | \$ | 281.89 | | |
| 1412152002 | | | | | | | | |
| Workers Compensation | Arthur J Gallagher Risk Mgmt Serv Inc | 1/8/2024 | 2022 WC Audit | 1/31/2024 | \$ | 140.04 | 1/16/2024 | 182263 |
| Total 01412152002: | | | | | \$ | 140.04 | | |
| 1412200002 | | | | | | | | |
| Miscellaneous Expense | James McCans | 12/28/2023 | Reimb. - Miscellaneous | 1/31/2024 | \$ | 417.81 | 1/9/2024 | 182252 |
| Total 01412200002: | | | | | \$ | 417.81 | | |
| 1412200202 | | | | | | | | |
| Office Supplies | Office Basics, Inc | 1/2/2024 | Office Supplies | 1/31/2024 | \$ | 9.40 | 2/12/2024 | 182462 |
| Office Supplies | Office Basics, Inc | 1/26/2024 | Office Supplies | 1/31/2024 | \$ | 9.40 | 2/12/2024 | 182462 |
| Total 01412200202: | | | | | \$ | 18.80 | | |
| 1412200402 | | | | | | | | |
| Medical Supplies | Bound Tree Medical LLC | 10/18/2023 | RETURN - (4) Batteries | 1/31/2024 | \$ | (168.76) | 2/12/2024 | 182368 |
| Medical Supplies | Bound Tree Medical LLC | 11/8/2023 | Medical Supplies | 1/31/2024 | \$ | 29.89 | 2/12/2024 | 182368 |
| Total 01412200402: | | | | | \$ | (138.87) | | |
| 1412201302 | | | | | | | | |
| Utilities | Peco Energy | 12/28/2023 | 2325 Darby Rd - Quatrani Bld | 1/31/2024 | \$ | 202.47 | 1/9/2024 | 182256 |
| Utilities | Peco Energy | 12/28/2023 | 800 Ardmore Ave | 1/31/2024 | \$ | 483.89 | 1/9/2024 | 182256 |
| Utilities | Aqua Pennsylvania | 1/16/2024 | 2325 Darby Rd | 1/31/2024 | \$ | 49.63 | 1/23/2024 | 182294 |
| Utilities | Peco Energy | 1/29/2024 | 2325 Darby Rd - Quatrani Bld | 2/29/2024 | \$ | 198.84 | 2/6/2024 | 182339 |
| Utilities | Peco Energy | 1/29/2024 | 800 Ardmore Ave | 2/29/2024 | \$ | 765.74 | 2/6/2024 | 182339 |
| Total 01412201302: | | | | | \$ | 1,700.57 | | |

| | | | | | | | | |
|-----------------------|---------------------------------------|------------|---|-----------|----|------------|-----------|--------|
| 1412280302 | | | | | | | | |
| Uniform Regular | James McCans | 12/30/2023 | Reimb - Uniform Pants | 1/31/2024 | \$ | 75.98 | 1/9/2024 | 182252 |
| Total 01412280302: | | | | | \$ | 75.98 | | |
| 1412290302 | | | | | | | | |
| Professional Services | Sinclair Exterminating Inc | 12/31/2023 | Exterminating - EMS | 1/31/2024 | \$ | 135.00 | 2/12/2024 | 182491 |
| Total 01412290302: | | | | | \$ | 135.00 | | |
| 1412300002 | | | | | | | | |
| Communications | Comcast | 1/6/2024 | Cable Service - 800 Ardmore Ave | 1/31/2024 | \$ | 383.27 | 1/16/2024 | 182267 |
| Communications | Comcast Business | 1/1/2024 | Cable Service | 1/31/2024 | \$ | 14.65 | 1/16/2024 | 182268 |
| Communications | Xtel Communications, Inc | 1/1/2024 | Phone Expense | 1/31/2024 | \$ | 6.66 | 1/16/2024 | 182293 |
| Communications | Comcast | 1/23/2024 | Cable Service - 2325 Darby Rd | 1/31/2024 | \$ | 321.92 | 1/30/2024 | 182314 |
| Communications | AT & T Mobility | 1/16/2024 | Cellular Service | 2/29/2024 | \$ | 357.83 | 2/6/2024 | 182331 |
| Total 01412300002: | | | | | \$ | 1,084.33 | | |
| 1412411702 | | | | | | | | |
| Vehicle Insurance | Arthur J Gallagher Risk Mgmt Serv Inc | 12/18/2023 | P & C Insurance Premium a€" 3rd Installment | 1/31/2024 | \$ | 2,285.90 | 1/30/2024 | 182312 |
| Total 01412411702: | | | | | \$ | 2,285.90 | | |
| 1412510002 | | | | | | | | |
| Vehicle Fuel | Petroleum Traders Corp | 12/27/2023 | Unleaded | 1/31/2024 | \$ | 248.80 | 2/12/2024 | 182473 |
| Vehicle Fuel | Petroleum Traders Corp | 1/19/2024 | Unleaded | 1/31/2024 | \$ | 268.92 | 2/12/2024 | 182473 |
| Vehicle Fuel | School District of Haverford Township | 1/29/2024 | Diesel Fuel | 1/31/2024 | \$ | 3,070.48 | 2/12/2024 | 182488 |
| Total 01412510002: | | | | | \$ | 3,588.20 | | |
| 1412510702 | | | | | | | | |
| Vehicle Maintenance | Church's Auto Parts | 1/23/2024 | (2) Tie Rods, Magnum Steer 108-7 | 1/31/2024 | \$ | 221.71 | 2/12/2024 | 182379 |
| Vehicle Maintenance | Mickey's Suburban Alignment Inc | 1/24/2024 | Alignment 108-7 | 1/31/2024 | \$ | 157.50 | 2/12/2024 | 182453 |
| Vehicle Maintenance | Pacifico Marple Ford | 12/22/2023 | Starter MSPO 108-7A | 1/31/2024 | \$ | 965.56 | 2/12/2024 | 182466 |
| Vehicle Maintenance | Pacifico Marple Ford | 1/9/2024 | Hose Raspo, Pump Asy, Thermostat 108-7A | 1/31/2024 | \$ | 822.88 | 2/12/2024 | 182466 |
| Vehicle Maintenance | Pacifico Marple Ford | 1/8/2024 | Pump Asy 108-7A | 1/31/2024 | \$ | 286.50 | 2/12/2024 | 182466 |
| Vehicle Maintenance | Pacifico Marple Ford | 1/9/2024 | Hose 108-7A | 1/31/2024 | \$ | 38.75 | 2/12/2024 | 182466 |
| Vehicle Maintenance | Pacifico Marple Ford | 1/22/2024 | Automatic Spo, Core 108-7A | 1/31/2024 | \$ | 6,950.00 | 2/12/2024 | 182466 |
| Vehicle Maintenance | Pacifico Marple Ford | 1/25/2024 | TCM Program for Trans 108-7A | 1/31/2024 | \$ | 184.99 | 2/12/2024 | 182466 |
| Vehicle Maintenance | Pacifico Marple Ford | 1/25/2024 | RETURN - Core | 1/31/2024 | \$ | (1,250.00) | 2/12/2024 | 182466 |
| Total 01412510702: | | | | | | 8,377.89 | | |
| 1413150002 | | | | | | | | |
| Life Insurance | North American Benefits Company | 1/22/2024 | Group Term Life Insurance | 1/31/2024 | \$ | 79.80 | 1/30/2024 | 182320 |
| Total 01413150002: | | | | | \$ | 79.80 | | |
| 1413150502 | | | | | | | | |
| Health Benefits | DelCo Public Schools Healthcare Trst | 1/2/2024 | Health Benefits | 1/31/2024 | \$ | 8,118.79 | 1/16/2024 | 182272 |
| Total 01413150502: | | | | | \$ | 8,118.79 | | |
| 1413151002 | | | | | | | | |
| Rx/Dental/Vision/LTD | Express Scripts Inc | 1/2/2024 | Prescription Benefits | 1/31/2024 | \$ | 717.54 | 1/9/2024 | 422 |
| Rx/Dental/Vision/LTD | Express Scripts Inc | 1/12/2024 | Prescription Benefits | 1/31/2024 | \$ | 71.02 | 1/12/2024 | 426 |
| Rx/Dental/Vision/LTD | Express Scripts Inc | 1/22/2024 | Prescription Benefits | 1/31/2024 | \$ | 14.68 | 1/30/2024 | 430 |
| Rx/Dental/Vision/LTD | Express Scripts Inc | 1/2/2024 | Prescription Benefits | 1/31/2024 | \$ | 717.54 | 1/9/2024 | 7092 |
| Rx/Dental/Vision/LTD | Express Scripts Inc | 1/2/2024 | Prescription Benefits | 1/31/2024 | \$ | (717.54) | 1/9/2024 | 7092 |
| Rx/Dental/Vision/LTD | North American Benefits Company | 1/22/2024 | Long Term Civilian Disability Insurance | 2/29/2024 | \$ | 188.34 | 2/6/2024 | 182337 |
| Total 01413151002: | | | | | \$ | 991.58 | | |
| 1413152002 | | | | | | | | |
| Workers Compensation | Arthur J Gallagher Risk Mgmt Serv Inc | 1/8/2024 | 2022 WC Audit | 1/31/2024 | \$ | 315.09 | 1/16/2024 | 182263 |
| Total 01413152002: | | | | | \$ | 315.09 | | |
| 1413200002 | | | | | | | | |
| Miscellaneous Expense | J & J Landscaping Management, LLC | 8/7/2023 | Prop Main't - 217 E Marthart | 1/31/2024 | \$ | 295.00 | 1/9/2024 | 182251 |
| Miscellaneous Expense | J & J Landscaping Management, LLC | 9/6/2023 | Prop Main't - 705 Haverford | 1/31/2024 | \$ | 865.00 | 1/9/2024 | 182251 |
| Miscellaneous Expense | J & J Landscaping Management, LLC | 9/6/2023 | Prop Main't - 701 Haverford | 1/31/2024 | \$ | 485.00 | 1/9/2024 | 182251 |
| Miscellaneous Expense | J & J Landscaping Management, LLC | 10/23/2023 | Prop Main't - 217 E Marthart | 1/31/2024 | \$ | 285.00 | 1/9/2024 | 182251 |
| Total 01413200002: | | | | | \$ | 1,930.00 | | |
| 1413200202 | | | | | | | | |
| Office Supplies | Hockeytown 19083 LLC | 1/18/2024 | (6) Shirts - Haverford Twp Codes | 1/31/2024 | \$ | 188.00 | 2/12/2024 | 182423 |
| Office Supplies | Nuss Printing Inc | 1/17/2024 | (2000) Construction Inspection Forms | 1/31/2024 | \$ | 277.00 | 2/12/2024 | 182461 |
| Office Supplies | Office Basics, Inc | 1/24/2024 | Office Supplies | 1/31/2024 | \$ | 17.16 | 2/12/2024 | 182462 |

| | | | | | | | | |
|--------------------------|---------------------------------------|------------|---|-----------|----|-----------|-----------|--------|
| Office Supplies | Office Basics, Inc | 1/27/2024 | Office Supplies | 1/31/2024 | \$ | 57.06 | 2/12/2024 | 182462 |
| Total 01413200202: | | | | | \$ | 539.22 | | |
| 1413210102 | | | | | | | | |
| Postage Expense | FP Finance Program | 12/27/2023 | Postage Meter Lease | 1/31/2024 | \$ | 31.25 | 1/9/2024 | 182250 |
| Postage Expense | FP Finance Program | 1/29/2024 | Postage Meter Lease | 2/29/2024 | \$ | 31.25 | 2/6/2024 | 182335 |
| Total 01413210102: | | | | | \$ | 62.50 | | |
| 1413290202 | | | | | | | | |
| Legal Expenses | Kilkenny Law, LLC | 1/2/2024 | Legal Services - General | 1/31/2024 | \$ | 87.50 | 2/12/2024 | 182437 |
| Total 01413290202: | | | | | \$ | 87.50 | | |
| 1413290302 | | | | | | | | |
| Prof Services - Special | Keystone Municipal Services, Inc | 12/30/2023 | Building Inspection Services | 1/31/2024 | \$ | 5,400.00 | 2/12/2024 | 182435 |
| Prof Services - Special | Keystone Municipal Services, Inc | 1/24/2024 | Building Inspection Services | 1/31/2024 | \$ | 5,925.00 | 2/12/2024 | 182435 |
| Total 01413290302: | | | | | \$ | 11,325.00 | | |
| 1413300002 | | | | | | | | |
| Communications | Comcast Business | 1/1/2024 | Cable Service | 1/31/2024 | \$ | 113.96 | 1/16/2024 | 182268 |
| Communications | Xtel Communications, Inc | 1/1/2024 | Phone Expense | 1/31/2024 | \$ | 51.83 | 1/16/2024 | 182293 |
| Communications | AT & T Mobility | 1/16/2024 | Cellular Service | 2/29/2024 | \$ | 357.83 | 2/6/2024 | 182331 |
| Total 01413300002: | | | | | \$ | 523.62 | | |
| 1413400002 | | | | | | | | |
| Copier Lease/Maintenance | Toshiba America Business Solutions | 12/25/2023 | Copier Maintenance | 1/31/2024 | \$ | 18.31 | 1/9/2024 | 182258 |
| Copier Lease/Maintenance | Toshiba Financial Service | 12/28/2023 | Copier Lease | 1/31/2024 | \$ | 62.72 | 1/9/2024 | 182259 |
| Copier Lease/Maintenance | Toshiba Financial Service | 1/23/2024 | Copier Lease | 1/31/2024 | \$ | 62.72 | 1/30/2024 | 182326 |
| Copier Lease/Maintenance | Toshiba America Business Solutions | 1/22/2024 | Copier Maintenance | 2/29/2024 | \$ | 10.81 | 2/6/2024 | 182344 |
| Total 01413400002: | | | | | \$ | 154.56 | | |
| 1413411702 | | | | | | | | |
| Vehicle Insurance | Arthur J Gallagher Risk Mgmt Serv Inc | 12/18/2023 | P & C Insurance Premium - 3rd Installment | 1/31/2024 | \$ | 1,714.43 | 1/30/2024 | 182312 |
| Total 01413411702: | | | | | \$ | 1,714.43 | | |
| 1413510002 | | | | | | | | |
| Vehicle Fuel | Petroleum Traders Corp | 12/27/2023 | Unleaded | 1/31/2024 | \$ | 123.72 | 2/12/2024 | 182473 |
| Vehicle Fuel | Petroleum Traders Corp | 1/19/2024 | Unleaded | 1/31/2024 | \$ | 107.45 | 2/12/2024 | 182473 |
| Total 01413510002: | | | | | \$ | 231.17 | | |
| 1416150002 | | | | | | | | |
| Life Insurance | North American Benefits Company | 1/22/2024 | Group Term Life Insurance | 1/31/2024 | \$ | 16.80 | 1/30/2024 | 182320 |
| Total 01416150002: | | | | | \$ | 16.80 | | |
| 1416150502 | | | | | | | | |
| Health Benefits | DelCo Public Schools Healthcare Trst | 1/2/2024 | Health Benefits | 1/31/2024 | \$ | 2,352.89 | 1/16/2024 | 182272 |
| Total 01416150502: | | | | | \$ | 2,352.89 | | |
| 1416151002 | | | | | | | | |
| Rx/Dental/Vision/LTD | Express Scripts Inc | 1/2/2024 | Prescription Benefits | 1/31/2024 | \$ | 43.35 | 1/9/2024 | 422 |
| Rx/Dental/Vision/LTD | Express Scripts Inc | 1/12/2024 | Prescription Benefits | 1/31/2024 | \$ | 125.21 | 1/12/2024 | 426 |
| Rx/Dental/Vision/LTD | Express Scripts Inc | 1/2/2024 | Prescription Benefits | 1/31/2024 | \$ | 43.35 | 1/9/2024 | 7092 |
| Rx/Dental/Vision/LTD | Express Scripts Inc | 1/2/2024 | Prescription Benefits | 1/31/2024 | \$ | (43.35) | 1/9/2024 | 7092 |
| Rx/Dental/Vision/LTD | North American Benefits Company | 1/22/2024 | Long Term Civilian Disability Insurance | 2/29/2024 | \$ | 48.09 | 2/6/2024 | 182337 |
| Total 01416151002: | | | | | \$ | 216.65 | | |
| 1416152002 | | | | | | | | |
| Workers Compensation | Arthur J Gallagher Risk Mgmt Serv Inc | 1/8/2024 | 2022 WC Audit | 1/31/2024 | \$ | 93.36 | 1/16/2024 | 182263 |
| Total 01416152002: | | | | | \$ | 93.36 | | |
| 1416200002 | | | | | | | | |
| Miscellaneous Expense | Sir Speedy Printing Center #7099 | 1/5/2024 | (6) Booklets - Zoning Chapter | 1/31/2024 | \$ | 110.00 | 2/12/2024 | 182492 |
| Total 01416200002: | | | | | \$ | 110.00 | | |
| 1416200202 | | | | | | | | |
| Office Supplies | Office Basics, Inc | 1/2/2024 | Office Supplies | 1/31/2024 | \$ | 9.40 | 2/12/2024 | 182462 |
| Office Supplies | Office Basics, Inc | 1/24/2024 | Office Supplies | 1/31/2024 | \$ | 20.32 | 2/12/2024 | 182462 |
| Office Supplies | Office Basics, Inc | 1/26/2024 | Office Supplies | 1/31/2024 | \$ | 9.40 | 2/12/2024 | 182462 |
| Total 01416200202: | | | | | \$ | 39.12 | | |
| 1416210102 | | | | | | | | |
| Postage Expense | FP Finance Program | 12/27/2023 | Postage Meter Lease | 1/31/2024 | \$ | 31.25 | 1/9/2024 | 182250 |
| Postage Expense | FP Finance Program | 1/29/2024 | Postage Meter Lease | 2/29/2024 | \$ | 31.25 | 2/6/2024 | 182335 |
| Total 01416210102: | | | | | \$ | 62.50 | | |

| | | | | | | | | |
|---------------------------|---------------------------------------|------------|---|-----------|---------------|-----------|--------|--|
| 1416210602 | | | | | | | | |
| Advertising | 21st Century Media-Philly Cluster | 12/27/2023 | Advertising | 1/31/2024 | \$ 413.88 | 2/12/2024 | 182346 | |
| Total 01416210602: | | | | | \$ 413.88 | | | |
| 1416290202 | | | | | | | | |
| Legal Expenses | Kilkenny Law, LLC | 1/2/2024 | Legal Services - General | 1/31/2024 | \$ 3,255.00 | 2/12/2024 | 182437 | |
| Legal Expenses | Kilkenny Law, LLC | 1/2/2024 | Legal Services - General Litigation | 1/31/2024 | \$ 245.00 | 2/12/2024 | 182437 | |
| Legal Expenses | Kilkenny Law, LLC | 1/2/2024 | Legal Services - Mandamus Litigation | 1/31/2024 | \$ 2,342.50 | 2/12/2024 | 182437 | |
| Legal Expenses | Raffaele & Puppio, LLP | 1/5/2024 | ZHB Solicitor - Appeals/Hearings | 1/31/2024 | \$ 2,951.00 | 2/12/2024 | 182482 | |
| Total 01416290202: | | | | | \$ 8,793.50 | | | |
| 1416290302 | | | | | | | | |
| Prof Svcs - Special Cases | Discover Haverford | 2/1/2024 | 2024 Quarterly Operating Contribution | 1/31/2024 | \$ 26,908.75 | 2/12/2024 | 182394 | |
| Prof Svcs - Special Cases | Keystone Municipal Services, Inc | 12/30/2023 | Building Inspection Services | 1/31/2024 | \$ 3,888.75 | 2/12/2024 | 182435 | |
| Prof Svcs - Special Cases | Keystone Municipal Services, Inc | 1/24/2024 | Building Inspection Services | 1/31/2024 | \$ 3,458.75 | 2/12/2024 | 182435 | |
| Prof Svcs - Special Cases | McNichol, Byrne, & Matlawski, PC | 1/17/2024 | Legal services - Billboards | 1/31/2024 | \$ 857.50 | 2/12/2024 | 182451 | |
| Prof Svcs - Special Cases | McNichol, Byrne, & Matlawski, PC | 1/17/2024 | Legal services - Starbucks | 1/31/2024 | \$ 17.50 | 2/12/2024 | 182451 | |
| Total 01416290302: | | | | | \$ 35,131.25 | | | |
| 1416290402 | | | | | | | | |
| Engineering Fees | Pennoni Associates, Inc | 2/1/2024 | Eagle Rd YMCA - Adt'l Easements | 1/31/2024 | \$ 930.00 | 2/12/2024 | 182469 | |
| Total 01416290402: | | | | | \$ 930.00 | | | |
| 1416300002 | | | | | | | | |
| Communications | Comcast Business | 1/1/2024 | Cable Service | 1/31/2024 | \$ 30.93 | 1/16/2024 | 182268 | |
| Communications | Xtel Communications, Inc | 1/1/2024 | Phone Expense | 1/31/2024 | \$ 14.07 | 1/16/2024 | 182293 | |
| Communications | AT & T Mobility | 1/16/2024 | Cellular Service | 2/29/2024 | \$ 44.73 | 2/6/2024 | 182331 | |
| Total 01416300002: | | | | | \$ 89.73 | | | |
| 1416400002 | | | | | | | | |
| Copier Lease/Maintenance | Toshiba America Business Solutions | 12/25/2023 | Copier Maintenance | 1/31/2024 | \$ 15.50 | 1/9/2024 | 182258 | |
| Copier Lease/Maintenance | Toshiba Financial Service | 12/28/2023 | Copier Lease | 1/31/2024 | \$ 51.46 | 1/9/2024 | 182259 | |
| Copier Lease/Maintenance | Toshiba Financial Service | 1/23/2024 | Copier Lease | 1/31/2024 | \$ 51.46 | 1/30/2024 | 182326 | |
| Copier Lease/Maintenance | Toshiba America Business Solutions | 1/22/2024 | Copier Maintenance | 2/29/2024 | \$ 9.00 | 2/6/2024 | 182344 | |
| Total 01416400002: | | | | | \$ 127.42 | | | |
| 1416901002 | | | | | | | | |
| Hearing Transcripts | Arlene M. LaRosa, RPR | 1/10/2024 | Court reporting | 1/31/2024 | \$ 397.00 | 2/12/2024 | 182360 | |
| Total 01416901002: | | | | | \$ 397.00 | | | |
| 1427150002 | | | | | | | | |
| Life Insurance | North American Benefits Company | 1/22/2024 | Group Term Life Insurance | 1/31/2024 | \$ 278.40 | 1/30/2024 | 182320 | |
| Total 01427150002: | | | | | \$ 278.40 | | | |
| 1427150502 | | | | | | | | |
| Health Benefits | DelCo Public Schools Healthcare Trst | 1/2/2024 | Health Benefits | 1/31/2024 | \$ 33,210.59 | 1/16/2024 | 182272 | |
| Total 01427150502: | | | | | \$ 33,210.59 | | | |
| 1427151002 | | | | | | | | |
| Rx/Dental/Vision/LTD | Express Scripts Inc | 1/2/2024 | Prescription Benefits | 1/31/2024 | \$ 1,427.67 | 1/9/2024 | 422 | |
| Rx/Dental/Vision/LTD | Express Scripts Inc | 1/12/2024 | Prescription Benefits | 1/31/2024 | \$ 1,746.67 | 1/12/2024 | 426 | |
| Rx/Dental/Vision/LTD | Express Scripts Inc | 1/22/2024 | Prescription Benefits | 1/31/2024 | \$ 302.89 | 1/30/2024 | 430 | |
| Rx/Dental/Vision/LTD | Express Scripts Inc | 1/2/2024 | Prescription Benefits | 1/31/2024 | \$ 1,427.67 | 1/9/2024 | 7092 | |
| Rx/Dental/Vision/LTD | Express Scripts Inc | 1/2/2024 | Prescription Benefits | 1/31/2024 | \$ (1,427.67) | 1/9/2024 | 7092 | |
| Rx/Dental/Vision/LTD | North American Benefits Company | 1/22/2024 | Long Term Civilian Disability Insurance | 2/29/2024 | \$ 557.63 | 2/6/2024 | 182337 | |
| Total 01427151002: | | | | | \$ 4,034.86 | | | |
| 1427152002 | | | | | | | | |
| Workers Compensation | Arthur J Gallagher Risk Mgmt Serv Inc | 1/8/2024 | 2022 WC Audit | 1/31/2024 | \$ 1,143.66 | 1/16/2024 | 182263 | |
| Total 01427152002: | | | | | \$ 1,143.66 | | | |
| 1427200002 | | | | | | | | |
| Miscellaneous Expense | Patrick McNelis | 1/30/2024 | Reimb - CDL | 2/29/2024 | \$ 78.00 | 2/6/2024 | 182338 | |
| Miscellaneous Expense | Sir Speedy Printing Center #7099 | 11/10/2023 | (2500) Door Hangers | 1/31/2024 | \$ 2,070.00 | 2/12/2024 | 182492 | |
| Total 01427200002: | | | | | \$ 2,148.00 | | | |
| 1427272202 | | | | | | | | |
| Trash Billing | Postmaster | 1/26/2024 | 2024 Tax Bill Postage | 1/31/2024 | \$ 3,531.94 | 1/26/2024 | 182310 | |
| Total 01427272202: | | | | | \$ 3,531.94 | | | |
| 1427277002 | | | | | | | | |
| Bulk Pick Up Expense | JPS Equipment Co., Inc | 1/31/2024 | Bulk Trash Collection | 1/31/2024 | \$ 5,459.00 | 2/12/2024 | 182432 | |

| | | | | | | | | |
|------------------------|---------------------------------------|------------|---|-----------|----|------------|-----------|--------|
| Total 01427277002: | | | | | \$ | 5,459.00 | | |
| 1427277102 | | | | | | | | |
| Recycling | BFI-King Of Prussia Recyclery | 12/31/2023 | Single Stream Recycling | 1/31/2024 | \$ | 36,005.27 | 2/12/2024 | 182366 |
| Recycling | Spectrum Letterbox | 1/2/2024 | 2024 Recycling Calendar Envelopes | 1/31/2024 | \$ | 1,325.00 | 2/12/2024 | 182493 |
| Recycling | Spectrum Letterbox | 1/2/2024 | 2024 Recycling Calenders Mailing | 1/31/2024 | \$ | 1,495.00 | 2/12/2024 | 182493 |
| Recycling | Spectrum Letterbox | 1/2/2024 | 2024 Recycling Calendar Mailing Printing | 1/31/2024 | \$ | 3,175.00 | 2/12/2024 | 182493 |
| Total 01427277102: | | | | | \$ | 42,000.27 | | |
| 1427277202 | | | | | | | | |
| Landfill/Disposal Cost | Delaware County Solid Waste Authority | 1/3/2024 | Municipal Waste | 1/31/2024 | \$ | 111,649.11 | 2/12/2024 | 182390 |
| Landfill/Disposal Cost | Delaware County Solid Waste Authority | 1/3/2024 | Municipal Waste | 1/31/2024 | \$ | (3,777.10) | 2/12/2024 | 182390 |
| Landfill/Disposal Cost | Victory Gardens Inc | 12/20/2023 | Brush Removal | 1/31/2024 | \$ | 200.00 | 2/12/2024 | 182514 |
| Landfill/Disposal Cost | Victory Gardens Inc | 12/13/2023 | Brush Removal | 1/31/2024 | \$ | 600.00 | 2/12/2024 | 182514 |
| Total 01427277202: | | | | | \$ | 108,672.01 | | |
| 1427280302 | | | | | | | | |
| Uniform Regular | James McCans | 12/28/2023 | Reimb. - Uniforms (Sharp Box) | 1/31/2024 | \$ | 74.22 | 1/9/2024 | 182252 |
| Uniform Regular | James McCans | 12/28/2023 | Reimb. - Uniforms | 1/31/2024 | \$ | 123.96 | 1/9/2024 | 182252 |
| Uniform Regular | Flocco Inc | 8/30/2023 | Work Boots | 1/31/2024 | \$ | 3,875.00 | 1/16/2024 | 182275 |
| Total 01427280302: | | | | | \$ | 4,073.18 | | |
| 1427300002 | | | | | | | | |
| Communications | Comcast | 1/17/2024 | Cable Service - 1 Hilltop Rd | 1/31/2024 | \$ | 78.42 | 1/23/2024 | 182300 |
| Communications | AT & T Mobility | 1/16/2024 | Cellular Service | 2/29/2024 | \$ | 89.46 | 2/6/2024 | 182331 |
| Total 01427300002: | | | | | \$ | 167.88 | | |
| 1427300102 | | | | | | | | |
| Radio Rent/Maintenance | Eagle Wireless Communications LLC | 1/15/2024 | Geotab Monthly Service - Public Works | 1/31/2024 | \$ | 288.77 | 2/12/2024 | 182397 |
| Total 01427300102: | | | | | \$ | 288.77 | | |
| 1427411702 | | | | | | | | |
| Vehicle Insurance | Arthur J Gallagher Risk Mgmt Serv Inc | 12/18/2023 | P & C Insurance Premium - 3rd Installment | 1/31/2024 | \$ | 6,057.64 | 1/30/2024 | 182312 |
| Total 01427411702: | | | | | \$ | 6,057.64 | | |
| 1427510002 | | | | | | | | |
| Vehicle Fuel | Petroleum Traders Corp | 12/27/2023 | Unleaded | 1/31/2024 | \$ | 241.82 | 2/12/2024 | 182473 |
| Vehicle Fuel | Petroleum Traders Corp | 1/19/2024 | Unleaded | 1/31/2024 | \$ | 209.98 | 2/12/2024 | 182473 |
| Vehicle Fuel | School District of Haverford Township | 1/29/2024 | Diesel Fuel | 1/31/2024 | \$ | 15,170.09 | 2/12/2024 | 182488 |
| Vehicle Fuel | School District of Haverford Township | 1/29/2024 | Diesel Fuel | 1/31/2024 | \$ | 84.37 | 2/12/2024 | 182488 |
| Vehicle Fuel | School District of Haverford Township | 1/29/2024 | Diesel Fuel | 1/31/2024 | \$ | 16.03 | 2/12/2024 | 182488 |
| Total 01427510002: | | | | | \$ | 15,722.29 | | |
| 1427510702 | | | | | | | | |
| Vehicle Maintenance | 95 Signs Inc | 1/10/2024 | Outfit S-18 | 1/31/2024 | \$ | 850.00 | 2/12/2024 | 182348 |
| Vehicle Maintenance | Ardmore Tire Inc | 12/20/2023 | (3) Tires S-22, 23 | 1/31/2024 | \$ | 760.00 | 2/12/2024 | 182359 |
| Vehicle Maintenance | Ardmore Tire Inc | 1/3/2024 | (4) Tires S-16, 17 | 1/31/2024 | \$ | 785.00 | 2/12/2024 | 182359 |
| Vehicle Maintenance | Ardmore Tire Inc | 1/6/2024 | Tires S-25 | 1/31/2024 | \$ | 350.00 | 2/12/2024 | 182359 |
| Vehicle Maintenance | Ardmore Tire Inc | 1/12/2024 | (5) Tires S-25, 26, 30 | 1/31/2024 | \$ | 1,025.00 | 2/12/2024 | 182359 |
| Vehicle Maintenance | Berrodin Parts Warehouse | 12/21/2023 | RETURN - Reman Altern, (2) Cores | 1/31/2024 | \$ | (399.03) | 2/12/2024 | 182364 |
| Vehicle Maintenance | Del-Val International Trucks, Inc | 12/18/2023 | Core S-30 | 1/31/2024 | \$ | 1,427.41 | 2/12/2024 | 182392 |
| Vehicle Maintenance | Del-Val International Trucks, Inc | 12/20/2023 | REFUND - Core | 1/31/2024 | \$ | (450.00) | 2/12/2024 | 182392 |
| Vehicle Maintenance | Del-Val International Trucks, Inc | 12/21/2023 | Sensor, Core S-24 | 1/31/2024 | \$ | 846.26 | 2/12/2024 | 182392 |
| Vehicle Maintenance | Del-Val International Trucks, Inc | 12/21/2023 | Nitrogen Sensor, Core S-24 | 1/31/2024 | \$ | 827.73 | 2/12/2024 | 182392 |
| Vehicle Maintenance | Del-Val International Trucks, Inc | 12/22/2023 | Turbocharge S-19 | 1/31/2024 | \$ | 1,800.98 | 2/12/2024 | 182392 |
| Vehicle Maintenance | Del-Val International Trucks, Inc | 12/22/2023 | Dual Filter S-20 | 1/31/2024 | \$ | 109.77 | 2/12/2024 | 182392 |
| Vehicle Maintenance | Del-Val International Trucks, Inc | 12/22/2023 | Filter, Belt, S-15, 17, 22, 24, 29, 30 | 1/31/2024 | \$ | 480.65 | 2/12/2024 | 182392 |
| Vehicle Maintenance | Del-Val International Trucks, Inc | 12/26/2023 | Air pipe, S-19 | 1/31/2024 | \$ | 271.56 | 2/12/2024 | 182392 |
| Vehicle Maintenance | Del-Val International Trucks, Inc | 1/4/2024 | Sendure Hose, Radiator Outlet S-27 | 1/31/2024 | \$ | 187.46 | 2/12/2024 | 182392 |
| Vehicle Maintenance | Del-Val International Trucks, Inc | 1/3/2024 | Blower Motor, Resistor Linear S-16 | 1/31/2024 | \$ | 431.45 | 2/12/2024 | 182392 |
| Vehicle Maintenance | Del-Val International Trucks, Inc | 1/4/2024 | Seal Kit, Sensor Assembly S-21 | 1/31/2024 | \$ | 487.70 | 2/12/2024 | 182392 |
| Vehicle Maintenance | Del-Val International Trucks, Inc | 1/8/2024 | (3) Press Fuel Kits S-21 | 1/31/2024 | \$ | 273.27 | 2/12/2024 | 182392 |
| Vehicle Maintenance | Del-Val International Trucks, Inc | 1/16/2024 | (2) Hoses S-27 | 1/31/2024 | \$ | 194.16 | 2/12/2024 | 182392 |
| Vehicle Maintenance | Del-Val International Trucks, Inc | 1/11/2024 | Hose Coolant, Tank Surge S-21 | 1/31/2024 | \$ | 591.25 | 2/12/2024 | 182392 |
| Vehicle Maintenance | Del-Val International Trucks, Inc | 1/12/2024 | Transmission, Core S-20 | 1/31/2024 | \$ | 8,947.89 | 2/12/2024 | 182392 |
| Vehicle Maintenance | GranTurk Equipment Company Inc | 12/20/2023 | Return Pipe S-27 | 1/31/2024 | \$ | 254.70 | 2/12/2024 | 182414 |
| Vehicle Maintenance | GranTurk Equipment Company Inc | 1/9/2024 | Hyco M-PTO S-26 | 1/31/2024 | \$ | 3,903.75 | 2/12/2024 | 182414 |

| | | | | | | | |
|-----------------------|---------------------------------------|------------|--|-----------|---------------|-----------|--------|
| Vehicle Maintenance | GranTurk Equipment Company Inc | 1/15/2024 | (4) New Style Solenoid S-23, 27 | 1/31/2024 | \$ 1,641.10 | 2/12/2024 | 182414 |
| Vehicle Maintenance | K & S Towing & Recovery Inc | 12/27/2023 | Towing S-22 | 1/31/2024 | \$ 678.00 | 2/12/2024 | 182433 |
| Vehicle Maintenance | Pacifico Marple Ford | 1/12/2024 | Fuel Filter S-100 | 1/31/2024 | \$ 185.00 | 2/12/2024 | 182466 |
| Vehicle Maintenance | Pacifico Marple Ford | 1/12/2024 | (2) Element Filters S-100 | 1/31/2024 | \$ 178.90 | 2/12/2024 | 182466 |
| Vehicle Maintenance | Penn Power Group | 12/27/2023 | Gasket, S-20 | 1/31/2024 | \$ 251.10 | 2/12/2024 | 182468 |
| Vehicle Maintenance | Penn Power Group | 12/29/2023 | Solenoid Assy, Harness Assy S-20 | 1/31/2024 | \$ 380.07 | 2/12/2024 | 182468 |
| Vehicle Maintenance | Triple R Truck Parts | 1/19/2024 | (8) Fender Guides, (3) Long Strokes | 1/31/2024 | \$ 862.33 | 2/12/2024 | 182504 |
| Vehicle Maintenance | TruckPro LLC Corp | 12/20/2023 | (10) Blade, (6) Batteries, S-21, 67, 17 | 1/31/2024 | \$ 960.54 | 2/12/2024 | 182507 |
| Vehicle Maintenance | TruckPro LLC Corp | 12/22/2023 | (6) Lube Filters S-24, 26, 27 | 1/31/2024 | \$ 165.94 | 2/12/2024 | 182507 |
| Vehicle Maintenance | TruckPro LLC Corp | 1/3/2024 | (2) Brk Kits,(2) Batteries S-30, 67 | 1/31/2024 | \$ 562.37 | 2/12/2024 | 182507 |
| Vehicle Maintenance | TruckPro LLC Corp | 1/10/2024 | (2) Brk Kits, (24) Brk Clnrs, (3) Lube Fltr S-27, 28 | 1/31/2024 | \$ 552.33 | 2/12/2024 | 182507 |
| Total 01427510702: | | | | | \$ 30,374.64 | | |
| 1427605002 | | | | | | | |
| Major Equipment | Ascendance Truck LLC | 1/5/2024 | 2024 Cab and Chassis S-18 | 1/31/2024 | \$ 107,983.00 | 1/23/2024 | 182295 |
| Major Equipment | GranTurk Equipment Company Inc | 12/15/2023 | Trash & Recycling Body S-18 | 1/31/2024 | \$ 93,664.50 | 1/23/2024 | 182303 |
| Total 01427605002: | | | | | \$ 201,647.50 | | |
| 1430150002 | | | | | | | |
| Life Insurance | North American Benefits Company | 1/22/2024 | Group Term Life Insurance | 1/31/2024 | \$ 354.90 | 1/30/2024 | 182320 |
| Total 01430150002: | | | | | \$ 354.90 | | |
| 1430150502 | | | | | | | |
| Health Benefits | DelCo Public Schools Healthcare Trst | 1/2/2024 | Health Benefits | 1/31/2024 | \$ 34,485.07 | 1/16/2024 | 182272 |
| Total 01430150502: | | | | | \$ 34,485.07 | | |
| 1430151002 | | | | | | | |
| Rx/Dental/Vision/LTD | Express Scripts Inc | 1/2/2024 | Prescription Benefits | 1/31/2024 | \$ 7,135.17 | 1/9/2024 | 422 |
| Rx/Dental/Vision/LTD | Express Scripts Inc | 1/12/2024 | Prescription Benefits | 1/31/2024 | \$ 6,044.10 | 1/12/2024 | 426 |
| Rx/Dental/Vision/LTD | Express Scripts Inc | 1/22/2024 | Prescription Benefits | 1/31/2024 | \$ 4,082.58 | 1/30/2024 | 430 |
| Rx/Dental/Vision/LTD | Express Scripts Inc | 1/2/2024 | Prescription Benefits | 1/31/2024 | \$ 7,135.17 | 1/9/2024 | 7092 |
| Rx/Dental/Vision/LTD | Express Scripts Inc | 1/2/2024 | Prescription Benefits | 1/31/2024 | \$ (7,135.17) | 1/9/2024 | 7092 |
| Rx/Dental/Vision/LTD | Vision Benefits of America | 1/5/2024 | Vision Benefits | 1/31/2024 | \$ 152.00 | 1/23/2024 | 182309 |
| Rx/Dental/Vision/LTD | North American Benefits Company | 1/22/2024 | Long Term Civilian Disability Insurance | 2/29/2024 | \$ 803.89 | 2/6/2024 | 182337 |
| Total 01430151002: | | | | | \$ 18,217.74 | | |
| 1430152002 | | | | | | | |
| Workers Compensation | Arthur J Gallagher Risk Mgmt Serv Inc | 1/8/2024 | 2022 WC Audit | 1/31/2024 | \$ 1,435.41 | 1/16/2024 | 182263 |
| Total 01430152002: | | | | | \$ 1,435.41 | | |
| 1430200002 | | | | | | | |
| Miscellaneous Expense | ReadyRefresh by Nestle Inc | 1/6/2024 | Water Service | 1/31/2024 | \$ 155.28 | 1/16/2024 | 182289 |
| Miscellaneous Expense | A-Jon Construction Inc | 12/13/2023 | Dump | 1/31/2024 | \$ 234.00 | 2/12/2024 | 182352 |
| Miscellaneous Expense | Bound Tree Medical LLC | 1/25/2024 | SafeGrip Gloves | 1/31/2024 | \$ 315.80 | 2/12/2024 | 182368 |
| Miscellaneous Expense | Cardone-Nuss Printing | 12/18/2023 | (6) Military Banners | 1/31/2024 | \$ 628.50 | 2/12/2024 | 182373 |
| Miscellaneous Expense | T. Frank McCall's, Inc | 1/11/2024 | Maintenance Items | 1/31/2024 | \$ 1,044.90 | 2/12/2024 | 182499 |
| Miscellaneous Expense | T. Frank McCall's, Inc | 1/25/2024 | Maintenance Items | 1/31/2024 | \$ 598.10 | 2/12/2024 | 182499 |
| Miscellaneous Expense | T. Frank McCall's, Inc | 1/29/2024 | Maintenance Items | 1/31/2024 | \$ 157.86 | 2/12/2024 | 182499 |
| Miscellaneous Expense | Yearsley's Service, Ltd | 1/3/2024 | (2) Keys | 1/31/2024 | \$ 14.00 | 2/12/2024 | 182519 |
| Total 01430200002: | | | | | \$ 3,148.44 | | |
| 1430200202 | | | | | | | |
| Office Supplies | Office Basics, Inc | 1/2/2024 | Office Supplies | 1/31/2024 | \$ 9.40 | 2/12/2024 | 182462 |
| Office Supplies | Office Basics, Inc | 1/3/2024 | Office Supplies | 1/31/2024 | \$ 191.50 | 2/12/2024 | 182462 |
| Office Supplies | Office Basics, Inc | 1/10/2024 | Office Supplies | 1/31/2024 | \$ 39.70 | 2/12/2024 | 182462 |
| Office Supplies | Office Basics, Inc | 1/10/2024 | Office Supplies | 1/31/2024 | \$ 94.00 | 2/12/2024 | 182462 |
| Office Supplies | Office Basics, Inc | 1/24/2024 | Office Supplies | 1/31/2024 | \$ 14.26 | 2/12/2024 | 182462 |
| Office Supplies | Office Basics, Inc | 1/26/2024 | Office Supplies | 1/31/2024 | \$ 9.40 | 2/12/2024 | 182462 |
| Office Supplies | Office Basics, Inc | 1/31/2024 | Office Supplies | 1/31/2024 | \$ 291.69 | 2/12/2024 | 182462 |
| Total 01430200202: | | | | | \$ 649.95 | | |
| 1430210102 | | | | | | | |
| Postage Expense | FP Finance Program | 12/27/2023 | Postage Meter Lease | 1/31/2024 | \$ 6.25 | 1/9/2024 | 182250 |
| Postage Expense | FP Finance Program | 1/29/2024 | Postage Meter Lease | 2/29/2024 | \$ 6.25 | 2/6/2024 | 182335 |
| Total 01430210102: | | | | | \$ 12.50 | | |
| 1430230802 | | | | | | | |
| Leaf Disposal | Foley Inc | 12/5/2023 | RETURN - Equipment Protection Plan | 1/31/2024 | \$ (2,631.12) | 1/23/2024 | 182302 |

| | | | | | | | | |
|---------------------------|---------------------------------------|------------|---|-----------|----|-----------|-----------|--------|
| Leaf Disposal | Foley Inc | 1/16/2024 | RETURN - Equipment Protection Plan | 1/31/2024 | \$ | (492.24) | 1/23/2024 | 182302 |
| Leaf Disposal | Foley Inc | 1/16/2024 | RETURN - Equipment Protection Plan | 1/31/2024 | \$ | (815.36) | 1/23/2024 | 182302 |
| Leaf Disposal | Foley Inc | 11/29/2023 | Rental - Wheel Loader | 1/31/2024 | \$ | 7,135.36 | 1/23/2024 | 182302 |
| Leaf Disposal | Foley Inc | 12/18/2023 | Rental - Wheel Loader | 1/31/2024 | \$ | 6,650.36 | 1/23/2024 | 182302 |
| Leaf Disposal | American Bio soils & Compost LLC | 12/20/2023 | Inbound Leaves | 1/31/2024 | \$ | 12,298.41 | 2/12/2024 | 182355 |
| Leaf Disposal | American Bio soils & Compost LLC | 12/25/2023 | Inbound Leaves | 1/31/2024 | \$ | 1,714.56 | 2/12/2024 | 182355 |
| Leaf Disposal | American Bio soils & Compost LLC | 1/6/2024 | Inbound Leaves | 1/31/2024 | \$ | 3,321.79 | 2/12/2024 | 182355 |
| Total 01430230802: | | | | | \$ | 27,181.76 | | |
| 1430273002 | | | | | | | | |
| Storm Sewers | Eagle Contracting & Landscaping, Inc | 12/22/2023 | Emergency Repairs - Eagle & Hollis | 1/31/2024 | \$ | 9,240.00 | 2/12/2024 | 182396 |
| Storm Sewers | Pennoni Associates, Inc | 2/1/2024 | Townshipwide Drainage Concerns | 1/31/2024 | \$ | 1,060.50 | 2/12/2024 | 182469 |
| Storm Sewers | Pennoni Associates, Inc | 2/1/2024 | Npdes App for Storm Sewers (ms4) | 1/31/2024 | \$ | 349.00 | 2/12/2024 | 182469 |
| Total 01430273002: | | | | | \$ | 10,649.50 | | |
| 1430280302 | | | | | | | | |
| Uniform Regular | Flocco Inc | 8/30/2023 | Work Boots | 1/31/2024 | \$ | 3,571.00 | 1/16/2024 | 182275 |
| Total 01430280302: | | | | | \$ | 3,571.00 | | |
| 1430290402 | | | | | | | | |
| Engineering Fees | Pennoni Associates, Inc | 2/1/2024 | General Traffic Issues | 1/31/2024 | \$ | 1,137.75 | 2/12/2024 | 182469 |
| Total 01430290402: | | | | | \$ | 1,137.75 | | |
| 1430300002 | | | | | | | | |
| Communications | Comcast Business | 1/1/2024 | Cable Service | 1/31/2024 | \$ | 45.58 | 1/16/2024 | 182268 |
| Communications | Xtel Communications, Inc | 1/1/2024 | Phone Expense | 1/31/2024 | \$ | 20.73 | 1/16/2024 | 182293 |
| Communications | Comcast | 1/17/2024 | Cable Service - 1 Hilltop Rd | 1/31/2024 | \$ | 78.43 | 1/23/2024 | 182300 |
| Communications | AT & T Mobility | 1/16/2024 | Cellular Service | 2/29/2024 | \$ | 313.10 | 2/6/2024 | 182331 |
| Total 01430300002: | | | | | \$ | 457.84 | | |
| 1430300102 | | | | | | | | |
| Radio Rent/Maintenance | Eagle Wireless Communications LLC | 1/15/2024 | Geotab Monthly Service - Public Works | 1/31/2024 | \$ | 288.78 | 2/12/2024 | 182397 |
| Total 01430300102: | | | | | \$ | 288.78 | | |
| 1430344202 | | | | | | | | |
| Contracted Services | Guidemark Inc | 1/15/2024 | Line Striping Parkview Drive | 1/31/2024 | \$ | 2,800.00 | 2/12/2024 | 182415 |
| Total 01430344202: | | | | | \$ | 2,800.00 | | |
| 1430400002 | | | | | | | | |
| Copier Lease/Maintenance | Toshiba America Business Solutions | 12/25/2023 | Copier Maintenance | 1/31/2024 | \$ | 15.50 | 1/9/2024 | 182258 |
| Copier Lease/Maintenance | Toshiba Financial Service | 12/28/2023 | Copier Lease | 1/31/2024 | \$ | 51.46 | 1/9/2024 | 182259 |
| Copier Lease/Maintenance | Toshiba Financial Service | 1/23/2024 | Copier Lease | 1/31/2024 | \$ | 51.46 | 1/30/2024 | 182326 |
| Copier Lease/Maintenance | Toshiba America Business Solutions | 1/22/2024 | Copier Maintenance | 2/29/2024 | \$ | 9.00 | 2/6/2024 | 182344 |
| Total 01430400002: | | | | | \$ | 127.42 | | |
| 1430411702 | | | | | | | | |
| Vehicle Insurance | Arthur J Gallagher Risk Mgmt Serv Inc | 12/18/2023 | P & C Insurance Premium - 3rd Installment | 1/31/2024 | \$ | 13,886.86 | 1/30/2024 | 182312 |
| Total 01430411702: | | | | | \$ | 13,886.86 | | |
| 1430430002 | | | | | | | | |
| Maint & Repair Equipment | Main Line Mower-Tree Care Supplies | 1/9/2024 | Service - Repair Muffler Threads | 1/31/2024 | \$ | 324.34 | 2/12/2024 | 182444 |
| Total 01430430002: | | | | | \$ | 324.34 | | |
| 1430430102 | | | | | | | | |
| Maint & Repair Facilities | Bird Control Services Inc | 1/3/2024 | Bird Control Services | 1/31/2024 | \$ | 102.00 | 2/12/2024 | 182367 |
| Maint & Repair Facilities | Grainger | 12/21/2023 | Thermostat | 1/31/2024 | \$ | 53.93 | 2/12/2024 | 182413 |
| Total 01430430102: | | | | | \$ | 155.93 | | |
| 1430510002 | | | | | | | | |
| Vehicle Fuel | PA DEP | 12/5/2023 | Storage Tank Permit - 1 Hilltop Road | 1/31/2024 | \$ | 50.00 | 1/30/2024 | 182321 |
| Vehicle Fuel | Petroleum Traders Corp | 12/27/2023 | Unleaded | 1/31/2024 | \$ | 1,827.73 | 2/12/2024 | 182473 |
| Vehicle Fuel | Petroleum Traders Corp | 12/27/2023 | Unleaded | 1/31/2024 | \$ | 224.95 | 2/12/2024 | 182473 |
| Vehicle Fuel | Petroleum Traders Corp | 1/19/2024 | Unleaded | 1/31/2024 | \$ | 1,587.10 | 2/12/2024 | 182473 |
| Vehicle Fuel | Petroleum Traders Corp | 1/19/2024 | Unleaded | 1/31/2024 | \$ | 195.33 | 2/12/2024 | 182473 |
| Vehicle Fuel | School District of Haverford Township | 1/29/2024 | Diesel Fuel | 1/31/2024 | \$ | 8,075.65 | 2/12/2024 | 182488 |
| Total 01430510002: | | | | | \$ | 11,960.76 | | |
| 1430510702 | | | | | | | | |
| Vehicle Maintenance | Foley Inc | 12/13/2023 | RETURN - Alternator | 1/31/2024 | \$ | (605.22) | 1/23/2024 | 182302 |
| Vehicle Maintenance | Foley Inc | 12/15/2023 | RETURN - Reporting Subscription | 1/31/2024 | \$ | (10.00) | 1/23/2024 | 182302 |
| Vehicle Maintenance | Foley Inc | 12/15/2023 | RETURN - Reporting Subscription | 1/31/2024 | \$ | (10.00) | 1/23/2024 | 182302 |

| | | | | | | | | |
|------------------------|------------------------------------|------------|---|-----------|----|------------|-----------|--------|
| Vehicle Maintenance | Foley Inc | 12/15/2023 | RETURN - Reporting Subscription | 1/31/2024 | \$ | (10.00) | 1/23/2024 | 182302 |
| Vehicle Maintenance | Foley Inc | 12/15/2023 | RETURN - Reporting Subscription | 1/31/2024 | \$ | (10.00) | 1/23/2024 | 182302 |
| Vehicle Maintenance | Foley Inc | 12/15/2023 | RETURN - Reporting Subscription | 1/31/2024 | \$ | (10.00) | 1/23/2024 | 182302 |
| Vehicle Maintenance | Foley Inc | 12/15/2023 | RETURN - Reporting Subscription | 1/31/2024 | \$ | (10.00) | 1/23/2024 | 182302 |
| Vehicle Maintenance | Foley Inc | 12/15/2023 | RETURN - Reporting Subscription | 1/31/2024 | \$ | (10.00) | 1/23/2024 | 182302 |
| Vehicle Maintenance | Foley Inc | 12/14/2023 | Monthly Reporting Subscription | 1/31/2024 | \$ | 10.00 | 1/23/2024 | 182302 |
| Vehicle Maintenance | Foley Inc | 12/14/2023 | Monthly Reporting Subscription | 1/31/2024 | \$ | 10.00 | 1/23/2024 | 182302 |
| Vehicle Maintenance | Foley Inc | 12/14/2023 | Monthly Reporting Subscription | 1/31/2024 | \$ | 10.00 | 1/23/2024 | 182302 |
| Vehicle Maintenance | Foley Inc | 12/14/2023 | Monthly Reporting Subscription | 1/31/2024 | \$ | 10.00 | 1/23/2024 | 182302 |
| Vehicle Maintenance | Foley Inc | 12/14/2023 | Monthly Reporting Subscription | 1/31/2024 | \$ | 10.00 | 1/23/2024 | 182302 |
| Vehicle Maintenance | Foley Inc | 12/14/2023 | Monthly Reporting Subscription | 1/31/2024 | \$ | 10.00 | 1/23/2024 | 182302 |
| Vehicle Maintenance | Foley Inc | 12/14/2023 | Monthly Reporting Subscription | 1/31/2024 | \$ | 10.00 | 1/23/2024 | 182302 |
| Vehicle Maintenance | Foley Inc | 12/19/2023 | Air Filter H-239 Skid | 1/31/2024 | \$ | 60.22 | 1/23/2024 | 182302 |
| Vehicle Maintenance | Berrodin Parts Warehouse | 1/9/2024 | Blower Motor, Resistor H-30 | 1/31/2024 | \$ | 164.31 | 2/12/2024 | 182364 |
| Vehicle Maintenance | Berrodin Parts Warehouse | 1/17/2024 | Reman Starter, Core H-51 | 1/31/2024 | \$ | 122.42 | 2/12/2024 | 182364 |
| Vehicle Maintenance | Berrodin Parts Warehouse | 1/18/2024 | Caliper, Core, Brake Hose B-3 | 1/31/2024 | \$ | 185.05 | 2/12/2024 | 182364 |
| Vehicle Maintenance | Berrodin Parts Warehouse | 1/19/2024 | (10) Exact Fit H-32, 36, 49, 73 | 1/31/2024 | \$ | 62.60 | 2/12/2024 | 182364 |
| Vehicle Maintenance | Berrodin Parts Warehouse | 1/19/2024 | (10) Exact Fit H-35, 70, 73 | 1/31/2024 | \$ | 62.60 | 2/12/2024 | 182364 |
| Vehicle Maintenance | Del-Val International Trucks, Inc | 12/29/2023 | Throttle inlet, Throttle inlet Core H-34 | 1/31/2024 | \$ | 593.68 | 2/12/2024 | 182392 |
| Vehicle Maintenance | Del-Val International Trucks, Inc | 1/5/2024 | Pan Assy, Pan Oil, Gasket Oil Suction H-37 | 1/31/2024 | \$ | 1,213.00 | 2/12/2024 | 182392 |
| Vehicle Maintenance | Imperial Supplies LLC | 1/3/2024 | Draw Bar H-60 | 1/31/2024 | \$ | 112.23 | 2/12/2024 | 182426 |
| Vehicle Maintenance | Kelly Industrial Supply | 1/19/2024 | (50) Hydraulic Hoses, (6) Steel Couplers H-32, 36, 49 | 1/31/2024 | \$ | 846.98 | 2/12/2024 | 182434 |
| Vehicle Maintenance | Kelly Industrial Supply | 1/19/2024 | (78) Hose Ends, (14) Swivel Crimps H-34, 39, 70, 73 | 1/31/2024 | \$ | 964.70 | 2/12/2024 | 182434 |
| Vehicle Maintenance | Kelly Industrial Supply | 1/24/2024 | (6) Steel Parts H-34, 39 | 1/31/2024 | \$ | 134.59 | 2/12/2024 | 182434 |
| Vehicle Maintenance | Linde Gas & Equipment Inc | 12/22/2023 | Cylinder Rental | 1/31/2024 | \$ | 214.07 | 2/12/2024 | 182439 |
| Vehicle Maintenance | McLenaghan Wholesale Tires Inc | 1/26/2024 | (2) Tires H-78 | 1/31/2024 | \$ | 322.00 | 2/12/2024 | 182450 |
| Vehicle Maintenance | Pacifico Marple Ford | 1/4/2024 | Fob Battery M-1 | 1/31/2024 | \$ | 9.74 | 2/12/2024 | 182466 |
| Vehicle Maintenance | Park's Best Car Wash Inc | 1/2/2024 | Car Washes | 1/31/2024 | \$ | 45.00 | 2/12/2024 | 182467 |
| Vehicle Maintenance | PetroChoice | 12/18/2023 | Yard Oil | 1/31/2024 | \$ | 978.49 | 2/12/2024 | 182472 |
| Vehicle Maintenance | PetroChoice | 12/19/2023 | Yard Oil | 1/31/2024 | \$ | 2,996.40 | 2/12/2024 | 182472 |
| Vehicle Maintenance | PetroChoice | 1/19/2024 | Yard Oil | 1/31/2024 | \$ | 5,316.63 | 2/12/2024 | 182472 |
| Vehicle Maintenance | Triple R Truck Parts | 1/18/2024 | (4) Cross Chains, (100) Straps H-37, 38, 49 | 1/31/2024 | \$ | 514.86 | 2/12/2024 | 182504 |
| Vehicle Maintenance | Triple R Truck Parts | 1/18/2024 | (96) Cross Chains H-32, 36, 70 | 1/31/2024 | \$ | 949.44 | 2/12/2024 | 182504 |
| Vehicle Maintenance | TruckPro LLC Corp | 1/10/2024 | (3) Batteries H-46, 52 | 1/31/2024 | \$ | 420.18 | 2/12/2024 | 182507 |
| Vehicle Maintenance | TruckPro LLC Corp | 1/24/2024 | (6) Batteries H-66, 70 | 1/31/2024 | \$ | 936.31 | 2/12/2024 | 182507 |
| Total 01430510702: | | | | | \$ | 16,620.28 | | |
| 1430600002 | | | | | | | | |
| Minor Equipment | Fisher's Ace Hardware | 1/23/2024 | Hose, Q-Connect Yard | 1/31/2024 | \$ | 66.98 | 2/12/2024 | 182405 |
| Minor Equipment | Galantino Supply Company Inc | 1/24/2024 | Chop Saw | 1/31/2024 | \$ | 1,310.50 | 2/12/2024 | 182410 |
| Minor Equipment | Main Line Mower-Tree Care Supplies | 1/25/2024 | Guide Bar, Saw, Filter Housing | 1/31/2024 | \$ | 431.97 | 2/12/2024 | 182444 |
| Total 01430600002: | | | | | \$ | 1,809.45 | | |
| 1430605002 | | | | | | | | |
| Major Equipment | Ascendance Truck Pennsylvania LLC | 1/24/2024 | 2024 Cab and Chassis H-73 | 1/31/2024 | \$ | 89,758.00 | 2/12/2024 | 182361 |
| Major Equipment | H A DeHart & Son | 1/18/2024 | Truck Body H-73 | 1/31/2024 | \$ | 79,985.00 | 2/12/2024 | 182416 |
| Total 01430605002: | | | | | \$ | 169,743.00 | | |
| 1432200002 | | | | | | | | |
| Miscellaneous Expense | Llanerch Diner | 1/25/2024 | Food - Snow Storm | 2/29/2024 | \$ | 251.85 | 2/6/2024 | 182336 |
| Total 01432200002: | | | | | \$ | 251.85 | | |
| 1432900602 | | | | | | | | |
| Snow Removal Materials | Aqua Pennsylvania | 12/20/2023 | 1 Hilltop Rd - Brine Machine | 1/31/2024 | \$ | 178.84 | 1/9/2024 | 182244 |
| Snow Removal Materials | Aqua Pennsylvania | 1/22/2024 | 1 Hilltop Rd - Brine Machine | 1/31/2024 | \$ | 169.75 | 1/30/2024 | 182311 |
| Snow Removal Materials | A Marinelli & Sons Inc | 1/26/2024 | (110) Calcium Pellets | 1/31/2024 | \$ | 2,634.50 | 2/12/2024 | 182349 |
| Snow Removal Materials | Eastern Salt Company Inc | 1/28/2024 | Rock Salt | 1/31/2024 | \$ | 5,119.08 | 2/12/2024 | 182399 |
| Total 01432900602: | | | | | \$ | 8,102.17 | | |
| 1434201402 | | | | | | | | |
| Street Lights Electric | Peco Energy | 12/28/2023 | Grove Rd | 1/31/2024 | \$ | 11.02 | 1/9/2024 | 182256 |
| Street Lights Electric | Peco Energy | 12/28/2023 | 2325B Darby Rd - Streetlights | 1/31/2024 | \$ | 28,617.42 | 1/9/2024 | 182256 |
| Street Lights Electric | Peco Energy | 1/29/2024 | Grove Rd | 2/29/2024 | \$ | 11.05 | 2/6/2024 | 182339 |
| Street Lights Electric | Peco Energy | 1/29/2024 | 2325B Darby Rd - Streetlights | 2/29/2024 | \$ | 28,699.69 | 2/6/2024 | 182339 |

| | | | | | | | |
|--------------------------------|--------------------------------------|------------|--|-----------|----|------------|------------------|
| Total 01434201402: | | | | | \$ | 57,339.18 | |
| 1434201502 | | | | | | | |
| Traffic Signals Electric | Peco Energy | 12/28/2023 | 2325 Darby Rd -Traffic Signals | 1/31/2024 | \$ | 2,312.69 | 1/9/2024 182256 |
| Traffic Signals Electric | Peco Energy | 1/29/2024 | 2325 Darby Rd -Traffic Signals | 2/29/2024 | \$ | 2,314.38 | 2/6/2024 182339 |
| Total 01434201502: | | | | | \$ | 4,627.07 | |
| 1434231202 | | | | | | | |
| Signal/Light Maintenance | Signal Service, Inc | 9/27/2023 | PA One Mark Out - Haverford Ardmore | 1/31/2024 | \$ | 120.00 | 2/12/2024 182490 |
| Signal/Light Maintenance | Signal Service, Inc | 9/27/2023 | PA One Mark Out - Darby & College | 1/31/2024 | \$ | 120.00 | 2/12/2024 182490 |
| Signal/Light Maintenance | Signal Service, Inc | 9/27/2023 | Darby & Benedict | 1/31/2024 | \$ | 412.50 | 2/12/2024 182490 |
| Signal/Light Maintenance | Signal Service, Inc | 10/6/2023 | Darby & Benedict | 1/31/2024 | \$ | 727.50 | 2/12/2024 182490 |
| Signal/Light Maintenance | Signal Service, Inc | 10/6/2023 | Coopertown School Lights | 1/31/2024 | \$ | 105.00 | 2/12/2024 182490 |
| Signal/Light Maintenance | Signal Service, Inc | 10/9/2023 | Darby & Llandillo | 1/31/2024 | \$ | 210.00 | 2/12/2024 182490 |
| Signal/Light Maintenance | Signal Service, Inc | 10/9/2023 | Darby & Llandillo | 1/31/2024 | \$ | 462.00 | 2/12/2024 182490 |
| Signal/Light Maintenance | Signal Service, Inc | 10/9/2023 | PA One Mark Out - Landover & Haverford | 1/31/2024 | \$ | 120.00 | 2/12/2024 182490 |
| Signal/Light Maintenance | Signal Service, Inc | 10/9/2023 | PA One Mark Out - Twp. Line & Warrior | 1/31/2024 | \$ | 120.00 | 2/12/2024 182490 |
| Signal/Light Maintenance | Signal Service, Inc | 10/9/2023 | Ardmore & Morris | 1/31/2024 | \$ | 210.00 | 2/12/2024 182490 |
| Signal/Light Maintenance | Signal Service, Inc | 10/9/2023 | PA One Mark Out - Darby & Dartmouth | 1/31/2024 | \$ | 120.00 | 2/12/2024 182490 |
| Signal/Light Maintenance | Signal Service, Inc | 10/23/2023 | Earlington & Mill | 1/31/2024 | \$ | 267.50 | 2/12/2024 182490 |
| Signal/Light Maintenance | Signal Service, Inc | 10/23/2023 | Earlington & Mill | 1/31/2024 | \$ | 412.50 | 2/12/2024 182490 |
| Signal/Light Maintenance | Signal Service, Inc | 10/23/2023 | PA One Mark Out - WCP & Darby | 1/31/2024 | \$ | 120.00 | 2/12/2024 182490 |
| Signal/Light Maintenance | Signal Service, Inc | 10/23/2023 | WCP & Eagle | 1/31/2024 | \$ | 1,050.00 | 2/12/2024 182490 |
| Signal/Light Maintenance | Signal Service, Inc | 10/23/2023 | Darby & Mill | 1/31/2024 | \$ | 315.00 | 2/12/2024 182490 |
| Signal/Light Maintenance | Signal Service, Inc | 10/30/2023 | PA One Mark Out - Darby & College | 1/31/2024 | \$ | 120.00 | 2/12/2024 182490 |
| Signal/Light Maintenance | Signal Service, Inc | 10/31/2023 | PA One Mark Out - Twp. Line & Warrior | 1/31/2024 | \$ | 120.00 | 2/12/2024 182490 |
| Signal/Light Maintenance | Signal Service, Inc | 10/31/2023 | PA One Mark Out - Drexel & Twp. Line | 1/31/2024 | \$ | 120.00 | 2/12/2024 182490 |
| Signal/Light Maintenance | Signal Service, Inc | 10/31/2023 | PA One Mark Out - Burmont & Steel | 1/31/2024 | \$ | 120.00 | 2/12/2024 182490 |
| Signal/Light Maintenance | Signal Service, Inc | 1/12/2024 | PA One Mark Out - Twp Line & WCP | 1/31/2024 | \$ | 120.00 | 2/12/2024 182490 |
| Signal/Light Maintenance | Signal Service, Inc | 1/12/2024 | Ellis Rd Flashers | 1/31/2024 | \$ | 1,674.00 | 2/12/2024 182490 |
| Signal/Light Maintenance | Signal Service, Inc | 1/12/2024 | PA One Mark Out - Darby & Mill | 1/31/2024 | \$ | 120.00 | 2/12/2024 182490 |
| Signal/Light Maintenance | Signal Service, Inc | 1/12/2024 | PA One Mark Out - Earlington & Brookline | 1/31/2024 | \$ | 120.00 | 2/12/2024 182490 |
| Signal/Light Maintenance | Signal Service, Inc | 1/12/2024 | PA One Mark Out - Twp Line & WCP | 1/31/2024 | \$ | 412.50 | 2/12/2024 182490 |
| Signal/Light Maintenance | Signal Service, Inc | 1/12/2024 | West Chester Pk & Eagle | 1/31/2024 | \$ | 912.50 | 2/12/2024 182490 |
| Signal/Light Maintenance | Signal Service, Inc | 1/12/2024 | West Chester Pk & Eagle | 1/31/2024 | \$ | 412.50 | 2/12/2024 182490 |
| Signal/Light Maintenance | Turtle & Hughes, Inc | 1/16/2024 | Material for Street Lights - INSURANCE | 1/31/2024 | \$ | 1,109.75 | 2/12/2024 182508 |
| Signal/Light Maintenance | Turtle & Hughes, Inc | 1/11/2024 | Material for Street Lights | 1/31/2024 | \$ | 1,562.50 | 2/12/2024 182508 |
| Total 01434231202: | | | | | \$ | 11,815.75 | |
| 1440223302 | | | | | | | |
| Life Insurance - Civilian Ret | North American Benefits Company | 1/22/2024 | Group Term Life Insurance | 1/31/2024 | \$ | 1,258.25 | 1/30/2024 182320 |
| Total 01440223302: | | | | | \$ | 1,258.25 | |
| 1440223902 | | | | | | | |
| Health Benefits - Civilian Ret | DelCo Public Schools Healthcare Trst | 1/2/2024 | Health Benefits | 1/31/2024 | \$ | 11,732.30 | 1/16/2024 182272 |
| Total 01440223902: | | | | | \$ | 11,732.30 | |
| 1440224602 | | | | | | | |
| Rx/Dental/Vision - Civ Retired | Express Scripts Inc | 1/2/2024 | Prescription Benefits | 1/31/2024 | \$ | 190.40 | 1/9/2024 422 |
| Rx/Dental/Vision - Civ Retired | Express Scripts Inc | 1/12/2024 | Prescription Benefits | 1/31/2024 | \$ | 1,818.95 | 1/12/2024 426 |
| Rx/Dental/Vision - Civ Retired | Express Scripts Inc | 1/12/2024 | Prescription Benefits | 1/31/2024 | \$ | 338.56 | 1/12/2024 426 |
| Rx/Dental/Vision - Civ Retired | Express Scripts Inc | 1/22/2024 | Prescription Benefits | 1/31/2024 | \$ | 720.66 | 1/30/2024 430 |
| Rx/Dental/Vision - Civ Retired | Express Scripts Inc | 1/22/2024 | Prescription Benefits | 1/31/2024 | \$ | 145.38 | 1/30/2024 430 |
| Rx/Dental/Vision - Civ Retired | Express Scripts Inc | 1/2/2024 | Prescription Benefits | 1/31/2024 | \$ | 190.40 | 1/9/2024 7092 |
| Rx/Dental/Vision - Civ Retired | Express Scripts Inc | 1/2/2024 | Prescription Benefits | 1/31/2024 | \$ | (190.40) | 1/9/2024 7092 |
| Total 01440224602: | | | | | | 3,213.95 | |
| 1440900702 | | | | | | | |
| Operating Subsidy - Library | Peco Energy | 12/28/2023 | 2325 Darby Rd | 1/31/2024 | \$ | 789.75 | 1/9/2024 182256 |
| Operating Subsidy - Library | Peco Energy | 12/28/2023 | 2325 Darby Rd - Electric Elevator Rm | 1/31/2024 | \$ | 80.31 | 1/9/2024 182256 |
| Operating Subsidy - Library | Peco Energy | 1/29/2024 | 2325 Darby Rd | 2/29/2024 | \$ | 1,302.89 | 2/6/2024 182339 |
| Operating Subsidy - Library | Peco Energy | 1/29/2024 | 2325 Darby Rd - Electric Elevator Rm | 2/29/2024 | \$ | 81.55 | 2/6/2024 182339 |
| Operating Subsidy - Library | Fisher's Ace Hardware | 1/9/2024 | (2) Carpet Bar | 1/31/2024 | \$ | 27.98 | 2/12/2024 182405 |
| Operating Subsidy - Library | Haverford Township Free Library | 2/1/2024 | Operating Subsidy/MMO Allocation | 1/31/2024 | \$ | 111,692.34 | 2/12/2024 182417 |
| Operating Subsidy - Library | Jacob Low Hardware | 1/9/2023 | Door Closer | 1/31/2024 | \$ | 69.98 | 2/12/2024 182428 |

| | | | | | | | | |
|----------------------------|--|------------|---|------------|----|------------|-----------|--------|
| Total 01440900702: | | | | | \$ | 114,044.80 | | |
| 1440900802 | | | | | | | | |
| Life Insurance - Library | North American Benefits Company | 1/22/2024 | Group Term Life Insurance | 1/31/2024 | \$ | 108.00 | 1/30/2024 | 182320 |
| Total 01440900802: | | | | | \$ | 108.00 | | |
| 1440900902 | | | | | | | | |
| Health Benefits - Library | DelCo Public Schools Healthcare Trst | 1/2/2024 | Health Benefits | 1/31/2024 | \$ | 9,418.49 | 1/16/2024 | 182272 |
| Total 01440900902: | | | | | \$ | 9,418.49 | | |
| 1440901002 | | | | | | | | |
| Rx/Dental/Vision - Library | Express Scripts Inc | 1/2/2024 | Prescription Benefits | 1/31/2024 | \$ | 10.56 | 1/9/2024 | 422 |
| Rx/Dental/Vision - Library | Express Scripts Inc | 1/12/2024 | Prescription Benefits | 1/31/2024 | \$ | 1,839.89 | 1/12/2024 | 426 |
| Rx/Dental/Vision - Library | Express Scripts Inc | 1/22/2024 | Prescription Benefits | 1/31/2024 | \$ | 6,839.89 | 1/30/2024 | 430 |
| Rx/Dental/Vision - Library | Express Scripts Inc | 1/2/2024 | Prescription Benefits | 1/31/2024 | \$ | 10.56 | 1/9/2024 | 7092 |
| Rx/Dental/Vision - Library | Express Scripts Inc | 1/2/2024 | Prescription Benefits | 1/31/2024 | \$ | (10.56) | 1/9/2024 | 7092 |
| Rx/Dental/Vision - Library | North American Benefits Company | 1/22/2024 | Long Term Civilian Disability Insurance | 2/29/2024 | \$ | 180.09 | 2/6/2024 | 182337 |
| Total 01440901002: | | | | | \$ | 8,870.43 | | |
| 1440902602 | | | | | | | | |
| Nitre Hall Maintenance | Peco Energy | 12/28/2023 | 1500 Karakung Dr - Nitre Hall | 1/31/2024 | \$ | 545.45 | 1/9/2024 | 182256 |
| Nitre Hall Maintenance | Aqua Pennsylvania | 1/16/2024 | 1414 Johnson Rd - Nitre Hall | 1/31/2024 | \$ | 61.13 | 1/23/2024 | 182294 |
| Nitre Hall Maintenance | Verizon | 1/9/2024 | Nitre Hall | 1/31/2024 | \$ | 61.18 | 1/23/2024 | 182308 |
| Nitre Hall Maintenance | Peco Energy | 1/29/2024 | 1500 Karakung Dr - Nitre Hall | 2/29/2024 | \$ | 1,128.37 | 2/6/2024 | 182339 |
| Total 01440902602: | | | | | \$ | 1,796.13 | | |
| 1440902702 | | | | | | | | |
| Federal Sch Maintenance | Peco Energy | 12/28/2023 | 169 Allgates Dr | 1/31/2024 | \$ | 39.73 | 1/9/2024 | 182256 |
| Federal Sch Maintenance | Aqua Pennsylvania | 1/17/2024 | 169 Allgates Dr - Federal School | 1/31/2024 | \$ | 61.13 | 1/30/2024 | 182311 |
| Federal Sch Maintenance | Peco Energy | 1/29/2024 | 169 Allgates Dr | 2/29/2024 | \$ | 36.40 | 2/6/2024 | 182339 |
| Federal Sch Maintenance | Superior Alarm Systems Inc | 2/4/2024 | Fire Alarm Monitoring - Federal School | 1/31/2024 | \$ | 120.00 | 2/12/2024 | 182498 |
| Total 01440902702: | | | | | \$ | 257.26 | | |
| 1440902802 | | | | | | | | |
| Grange Maintenance | Peco Energy | 12/28/2023 | 201 Myrtle Ave - Carr Hse | 1/31/2024 | \$ | 606.03 | 1/9/2024 | 182256 |
| Grange Maintenance | Peco Energy | 12/28/2023 | 201 Myrtle Ave - Longbarn | 1/31/2024 | \$ | 42.84 | 1/9/2024 | 182256 |
| Grange Maintenance | Peco Energy | 12/28/2023 | 143 Myrtle Ave | 1/31/2024 | \$ | 1,077.83 | 1/9/2024 | 182256 |
| Grange Maintenance | Aqua Pennsylvania | 1/16/2024 | ES Myrtle Ave - Grange | 1/31/2024 | \$ | 90.31 | 1/23/2024 | 182294 |
| Grange Maintenance | Aqua Pennsylvania | 1/16/2024 | 139 Myrtle Ave - Grange | 1/31/2024 | \$ | 105.33 | 1/23/2024 | 182294 |
| Grange Maintenance | Constellation NewEnergy Gas Division LLC | 1/25/2024 | Natural Gas - 143 Myrtle Rd | 1/31/2024 | \$ | 345.31 | 1/30/2024 | 182315 |
| Grange Maintenance | Peco Energy | 1/29/2024 | 201 Myrtle Ave - Carr Hse | 2/29/2024 | \$ | 759.78 | 2/6/2024 | 182339 |
| Grange Maintenance | Peco Energy | 1/29/2024 | 201 Myrtle Ave - Longbarn | 2/29/2024 | \$ | 47.19 | 2/6/2024 | 182339 |
| Grange Maintenance | Peco Energy | 1/29/2024 | 143 Myrtle Ave | 2/29/2024 | \$ | 1,417.18 | 2/6/2024 | 182339 |
| Grange Maintenance | Superior Alarm Systems Inc | 1/1/2024 | Fire Alarm Monitoring - 143 Myrtle | 1/31/2024 | \$ | 75.00 | 2/12/2024 | 182498 |
| Total 01440902802: | | | | | \$ | 4,566.80 | | |
| 1440902902 | | | | | | | | |
| Environmental Advisory | Plant Signs | 12/11/2023 | (100) Engraved Plant Signs & Stakes | 12/31/2023 | \$ | (1,437.47) | 1/17/2024 | 182093 |
| Environmental Advisory | Mothers Compost LLC | 1/1/2024 | Hford Incentive Reporting 10/23 - 12/23 | 1/31/2024 | \$ | 1,200.00 | 1/9/2024 | 182254 |
| Environmental Advisory | Zedd360 LLC | 1/1/2024 | Composting (USDA Grant) | 1/31/2024 | \$ | 45.60 | 1/9/2024 | 182260 |
| Environmental Advisory | Mothers Compost LLC | 1/18/2024 | Compost Workshop Speaker | 1/31/2024 | \$ | 100.00 | 2/12/2024 | 182456 |
| Total 01440902902: | | | | | \$ | (91.87) | | |
| 1440908202 | | | | | | | | |
| Haverford Day Expenses | Jacob Low Hardware | 10/2/2023 | Bit, Eye Bolt, Anchors | 1/31/2024 | \$ | 23.54 | 1/16/2024 | 182282 |
| Total 01440908202: | | | | | \$ | 23.54 | | |
| 1450150002 | | | | | | | | |
| Life Insurance | North American Benefits Company | 1/22/2024 | Group Term Life Insurance | 1/31/2024 | \$ | 108.00 | 1/30/2024 | 182320 |
| Total 01450150002: | | | | | \$ | 108.00 | | |
| 1450150502 | | | | | | | | |
| Health Benefits | DelCo Public Schools Healthcare Trst | 1/2/2024 | Health Benefits | 1/31/2024 | \$ | 15,174.24 | 1/16/2024 | 182272 |
| Total 01450150502: | | | | | \$ | 15,174.24 | | |
| 1450151002 | | | | | | | | |
| Rx/Dental/Vision/LTD | Express Scripts Inc | 1/2/2024 | Prescription Benefits | 1/31/2024 | \$ | 98.93 | 1/9/2024 | 422 |
| Rx/Dental/Vision/LTD | Express Scripts Inc | 1/12/2024 | Prescription Benefits | 1/31/2024 | \$ | 1,694.20 | 1/12/2024 | 426 |
| Rx/Dental/Vision/LTD | Express Scripts Inc | 1/22/2024 | Prescription Benefits | 1/31/2024 | \$ | 133.21 | 1/30/2024 | 430 |
| Rx/Dental/Vision/LTD | Express Scripts Inc | 1/2/2024 | Prescription Benefits | 1/31/2024 | \$ | 98.93 | 1/9/2024 | 7092 |

| | | | | | | | | |
|----------------------------|---------------------------------------|------------|---|------------|----|-----------|-----------|--------|
| Rx/Dental/Vision/LTD | Express Scripts Inc | 1/2/2024 | Prescription Benefits | 1/31/2024 | \$ | (98.93) | 1/9/2024 | 7092 |
| Rx/Dental/Vision/LTD | Vision Benefits of America | 1/5/2024 | Vision Benefits | 1/31/2024 | \$ | 50.00 | 1/23/2024 | 182309 |
| Rx/Dental/Vision/LTD | North American Benefits Company | 1/22/2024 | Long Term Civilian Disability Insurance | 2/29/2024 | \$ | 236.72 | 2/6/2024 | 182337 |
| Total 01450151002: | | | | | \$ | 2,213.06 | | |
| 1450152002 | | | | | | | | |
| Workers Compensation | Arthur J Gallagher Risk Mgmt Serv Inc | 1/8/2024 | 2022 WC Audit | 1/31/2024 | \$ | 956.94 | 1/16/2024 | 182263 |
| Total 01450152002: | | | | | \$ | 956.94 | | |
| 1450200202 | | | | | | | | |
| Office Supplies | Office Basics, Inc | 1/4/2024 | Office Supplies | 1/31/2024 | \$ | 450.58 | 2/12/2024 | 182462 |
| Office Supplies | Office Basics, Inc | 1/4/2024 | Office Supplies | 1/31/2024 | \$ | 33.16 | 2/12/2024 | 182462 |
| Office Supplies | Office Basics, Inc | 1/19/2024 | Office Supplies | 1/31/2024 | \$ | 131.38 | 2/12/2024 | 182462 |
| Office Supplies | Office Basics, Inc | 1/24/2024 | Office Supplies | 1/31/2024 | \$ | 382.40 | 2/12/2024 | 182462 |
| Total 01450200202: | | | | | \$ | 997.52 | | |
| 1450201302 | | | | | | | | |
| Utilities | Peco Energy | 12/28/2023 | 9000 Parkview - Rec Ctr | 1/31/2024 | \$ | 5,206.01 | 1/9/2024 | 182256 |
| Utilities | Aqua Pennsylvania | 1/17/2024 | 900 Parkview Dr - Water Serv | 1/31/2024 | \$ | 309.55 | 1/30/2024 | 182311 |
| Utilities | Peco Energy | 1/29/2024 | 9000 Parkview - Rec Ctr | 2/29/2024 | \$ | 6,452.85 | 2/6/2024 | 182339 |
| Total 01450201302: | | | | | \$ | 11,968.41 | | |
| 1450210102 | | | | | | | | |
| Postage Expense | FP Finance Program | 12/27/2023 | Postage Meter Lease | 1/31/2024 | \$ | 3.75 | 1/9/2024 | 182250 |
| Postage Expense | FP Finance Program | 1/29/2024 | Postage Meter Lease | 2/29/2024 | \$ | 3.75 | 2/6/2024 | 182335 |
| Total 01450210102: | | | | | \$ | 7.50 | | |
| 1450227002 | | | | | | | | |
| Program Insurance | Arthur J Gallagher Risk Mgmt Serv Inc | 10/30/2023 | 2022 - 23 Accident Policy | 1/31/2024 | \$ | 5,261.00 | 1/16/2024 | 182263 |
| Total 01450227002: | | | | | \$ | 5,261.00 | | |
| 1450260002 | | | | | | | | |
| Assoc Dues & Membership | NRPA | 1/22/2024 | Membership Fee - B Barrett | 1/31/2024 | \$ | 180.00 | 2/12/2024 | 182460 |
| Total 01450260002: | | | | | \$ | 180.00 | | |
| 1450260202 | | | | | | | | |
| Training | Eileen Mottola | 1/8/2024 | Reimb - Ministerium Breakfast | 1/31/2024 | \$ | 60.55 | 1/16/2024 | 182274 |
| Training | Eileen Mottola | 1/22/2024 | Reimb - Senior Night Out | 1/31/2024 | \$ | 157.72 | 1/30/2024 | 182317 |
| Total 01450260202: | | | | | \$ | 218.27 | | |
| 1450300002 | | | | | | | | |
| Communications | Comcast Business | 1/1/2024 | Cable Service | 1/31/2024 | \$ | 53.72 | 1/16/2024 | 182268 |
| Communications | Xtel Communications, Inc | 1/1/2024 | Phone Expense | 1/31/2024 | \$ | 24.44 | 1/16/2024 | 182293 |
| Communications | Comcast | 1/14/2024 | Cable Service - 9000 Parkview Dr BUS2 | 1/31/2024 | \$ | 131.90 | 1/23/2024 | 182296 |
| Communications | Comcast | 1/14/2024 | Cable Service - 9000 Parkview Dr - REC | 1/31/2024 | \$ | 655.01 | 1/23/2024 | 182297 |
| Communications | AT & T Mobility | 1/16/2024 | Cellular Service | 2/29/2024 | \$ | 134.18 | 2/6/2024 | 182331 |
| Total 01450300002: | | | | | \$ | 999.25 | | |
| 1450400002 | | | | | | | | |
| Copier Lease/Maintenance | Toshiba America Business Solutions | 12/25/2023 | Copier Maintenance | 1/31/2024 | \$ | 176.05 | 1/9/2024 | 182258 |
| Copier Lease/Maintenance | Toshiba Financial Service | 12/28/2023 | Copier Lease | 1/31/2024 | \$ | 250.89 | 1/9/2024 | 182259 |
| Copier Lease/Maintenance | Toshiba Financial Service | 1/23/2024 | Copier Lease | 1/31/2024 | \$ | 250.89 | 1/30/2024 | 182326 |
| Copier Lease/Maintenance | Toshiba America Business Solutions | 1/22/2024 | Copier Maintenance | 2/29/2024 | \$ | 143.71 | 2/6/2024 | 182344 |
| Total 01450400002: | | | | | \$ | 821.54 | | |
| 1450411702 | | | | | | | | |
| Vehicle Insurance | Arthur J Gallagher Risk Mgmt Serv Inc | 12/18/2023 | P & C Insurance Premium - 3rd Installment | 1/31/2024 | \$ | 2,000.16 | 1/30/2024 | 182312 |
| Total 01450411702: | | | | | \$ | 2,000.16 | | |
| 1450510002 | | | | | | | | |
| Vehicle Fuel | Petroleum Traders Corp | 12/27/2023 | Unleaded | 1/31/2024 | \$ | 202.45 | 2/12/2024 | 182473 |
| Vehicle Fuel | Petroleum Traders Corp | 1/19/2024 | Unleaded | 1/31/2024 | \$ | 175.80 | 2/12/2024 | 182473 |
| Total 01450510002: | | | | | \$ | 378.25 | | |
| 1450922002 | | | | | | | | |
| Recreation Program Expense | Arbiter Sports | 1/11/2024 | Referees for Havertown Hoops | 1/31/2024 | \$ | 5,000.00 | 1/12/2024 | 428 |
| Recreation Program Expense | Dana Grossi | 12/14/2023 | Instructor - Safe Sitter | 12/31/2023 | \$ | (225.00) | 1/24/2024 | 182152 |
| Recreation Program Expense | Brian Barrett | 12/28/2023 | Reimb - NY Rockin Eve Refreshments | 1/31/2024 | \$ | 149.10 | 1/9/2024 | 182245 |
| Recreation Program Expense | Carol A Fee | 12/28/2023 | Instructor - Zumba 12/27 | 1/31/2024 | \$ | 35.00 | 1/9/2024 | 182246 |
| Recreation Program Expense | Kevin Towell | 12/29/2023 | Instructor - Rockin New Years Eve Bash | 1/31/2024 | \$ | 150.00 | 1/9/2024 | 182253 |
| Recreation Program Expense | Nicole Baker | 12/29/2023 | Instructor - Flow Yoga | 1/31/2024 | \$ | 100.00 | 1/9/2024 | 182255 |

| | | | | | | | |
|----------------------------|---------------------------------------|------------|--|------------|--------------|-----------|--------|
| Recreation Program Expense | Beth Ann Rush | 1/8/2024 | Instructor - Forever Fit Sub | 1/31/2024 | \$ 30.00 | 1/16/2024 | 182264 |
| Recreation Program Expense | Caroline D Scott | 1/4/2024 | Instructor - Supervisor, Scorekeeper | 1/31/2024 | \$ 263.00 | 1/30/2024 | 182313 |
| Recreation Program Expense | Dana Visanska | 12/14/2023 | Instructor - Safe Sitter | 12/31/2023 | \$ 225.00 | 1/30/2024 | 182316 |
| Recreation Program Expense | Jake Ritter | 1/3/2024 | Instructor - Havertown Hoops | 1/31/2024 | \$ 535.50 | 1/30/2024 | 182319 |
| Recreation Program Expense | Philadelphia Zoo | 1/26/2024 | ECP Trip - Promo BIRDS24 (#1E3DEEE57) | 1/31/2024 | \$ 50.00 | 1/30/2024 | 182322 |
| Recreation Program Expense | Staci Gillespie | 1/4/2024 | Instructor - Havertown Hoops | 1/31/2024 | \$ 802.50 | 1/30/2024 | 182325 |
| Recreation Program Expense | Arnold's Family Fun Center | 2/2/2024 | Deposit - ECP Trip 7/3/24 | 2/29/2024 | \$ 250.00 | 2/6/2024 | 182330 |
| Recreation Program Expense | Arnold's Family Fun Center | 2/2/2024 | Deposit - Huck Trip 7/9/2024 | 2/29/2024 | \$ 75.00 | 2/6/2024 | 182330 |
| Recreation Program Expense | Urban Air - Delco | 2/1/2024 | Deposit - Teen Adventure Trip 8/2/24 | 2/29/2024 | \$ 322.99 | 2/6/2024 | 182345 |
| Recreation Program Expense | Urban Air - Delco | 2/1/2024 | Deposit - ECP Trip 7/12/2024 | 2/29/2024 | \$ 939.99 | 2/6/2024 | 182345 |
| Recreation Program Expense | Urban Air - Delco | 2/1/2024 | Deposit - Pippi Trip 7/26/2024 | 2/29/2024 | \$ 284.99 | 2/6/2024 | 182345 |
| Recreation Program Expense | Aidan M Chivalette | 1/25/2024 | Scorekeeper - Havertown Hoops | 1/31/2024 | \$ 289.00 | 2/12/2024 | 182350 |
| Recreation Program Expense | Aidan McBrearty | 1/4/2024 | Instructor - Rockin' New Year's Eve Bash | 1/31/2024 | \$ 66.00 | 2/12/2024 | 182351 |
| Recreation Program Expense | Aidan McBrearty | 1/8/2024 | Instructor - Kids Night Out | 1/31/2024 | \$ 45.00 | 2/12/2024 | 182351 |
| Recreation Program Expense | Allison Fineberg | 2/1/2024 | Instructor - Little Explorers | 1/31/2024 | \$ 42.00 | 2/12/2024 | 182354 |
| Recreation Program Expense | Anthony Campese | 1/9/2024 | Instructor - Kids Night Out | 1/31/2024 | \$ 48.00 | 2/12/2024 | 182357 |
| Recreation Program Expense | Beth Ann Rush | 1/11/2024 | Instructor - SS Chair Yoga The | 1/31/2024 | \$ 120.00 | 2/12/2024 | 182365 |
| Recreation Program Expense | Beth Ann Rush | 1/11/2024 | Instructor - SS Classic Fri | 1/31/2024 | \$ 120.00 | 2/12/2024 | 182365 |
| Recreation Program Expense | Beth Ann Rush | 1/11/2024 | Instructor - SS & Sen Chair Yoga Tue | 1/31/2024 | \$ 150.00 | 2/12/2024 | 182365 |
| Recreation Program Expense | Beth Ann Rush | 1/11/2024 | Instructor - SS Chair Yoga Fri | 1/31/2024 | \$ 120.00 | 2/12/2024 | 182365 |
| Recreation Program Expense | Beth Ann Rush | 1/11/2024 | Instructor - SSC & Sen Fit Mon | 1/31/2024 | \$ 90.00 | 2/12/2024 | 182365 |
| Recreation Program Expense | Beth Ann Rush | 1/11/2024 | Instructor - Hatha Yoga Tue | 1/31/2024 | \$ 200.00 | 2/12/2024 | 182365 |
| Recreation Program Expense | Brian James Bausman Jr | 1/31/2024 | Scorekeeper | 1/31/2024 | \$ 357.00 | 2/12/2024 | 182369 |
| Recreation Program Expense | Bryce Pivovarnik | 1/31/2023 | Scorekeeper | 1/31/2024 | \$ 289.00 | 2/12/2024 | 182371 |
| Recreation Program Expense | Bryn Mawr Racing Company | 12/4/2023 | Race Timing & Management - Chilly Trail Run 5K | 1/31/2024 | \$ 460.00 | 2/12/2024 | 182372 |
| Recreation Program Expense | Carol A Fee | 1/11/2024 | Instructor - Zumba Sat | 1/31/2024 | \$ 140.00 | 2/12/2024 | 182374 |
| Recreation Program Expense | Carol A Fee | 1/11/2024 | Instructor - Zumba Wed | 1/31/2024 | \$ 175.00 | 2/12/2024 | 182374 |
| Recreation Program Expense | Caroline D Scott | 1/18/2024 | Instructor - Supervisor, Scorekeeper | 1/31/2024 | \$ 145.00 | 2/12/2024 | 182375 |
| Recreation Program Expense | Charles E Watkins | 1/11/2024 | Instructor - Breathe Just Breathe | 1/31/2024 | \$ 140.00 | 2/12/2024 | 182377 |
| Recreation Program Expense | Daniel Gallagher | 1/31/2024 | Instructor - Havertown Hoops | 1/31/2024 | \$ 322.50 | 2/12/2024 | 182386 |
| Recreation Program Expense | Daniel Henry Bell | 1/11/2024 | Instructor - Littl Dribblers, Rockin New Years | 1/31/2024 | \$ 159.25 | 2/12/2024 | 182387 |
| Recreation Program Expense | Daniel Henry Bell | 1/31/2024 | Instructor - Basketball Clinic | 1/31/2024 | \$ 57.00 | 2/12/2024 | 182387 |
| Recreation Program Expense | Deborah Saldana | 1/11/2024 | Instructor - Barre | 1/31/2024 | \$ 120.00 | 2/12/2024 | 182389 |
| Recreation Program Expense | Elizabeth Luff | 1/11/2024 | Instructor - Dancing Divas 65+ | 1/31/2024 | \$ 200.00 | 2/12/2024 | 182400 |
| Recreation Program Expense | Grace Baraldi | 1/25/2024 | Instructor - Kids Night Out | 1/31/2024 | \$ 45.00 | 2/12/2024 | 182412 |
| Recreation Program Expense | Jake Ritter | 1/31/2024 | Instructor - Havertown Hoops | 1/31/2024 | \$ 548.25 | 2/12/2024 | 182429 |
| Recreation Program Expense | Kieran Gillespie | 1/31/2024 | Scorekeeper | 1/31/2024 | \$ 425.00 | 2/12/2024 | 182436 |
| Recreation Program Expense | Lauren DiMartino | 1/11/2024 | Instructor - Zumba | 1/31/2024 | \$ 105.00 | 2/12/2024 | 182438 |
| Recreation Program Expense | Lisa A Drake | 1/11/2024 | Instructor - The Pound Workout | 1/31/2024 | \$ 175.00 | 2/12/2024 | 182440 |
| Recreation Program Expense | LogoWear House Inc | 12/22/2023 | (19) Shirts - Havertown Hoops Staff | 1/31/2024 | \$ 342.00 | 2/12/2024 | 182442 |
| Recreation Program Expense | LogoWear House Inc | 12/29/2023 | (151) Shirts - Chilly Trail Run | 1/31/2024 | \$ 1,397.75 | 2/12/2024 | 182442 |
| Recreation Program Expense | LogoWear House Inc | 1/20/2024 | (26) Shirts - Haverford Twp Parks & Rec Staff | 1/31/2024 | \$ 491.00 | 2/12/2024 | 182442 |
| Recreation Program Expense | Maeve Hegarty | 1/3/2024 | Instructor - Rockin New Years Eve Bash | 1/31/2024 | \$ 48.00 | 2/12/2024 | 182443 |
| Recreation Program Expense | Mary Pat Hartline | 1/11/2024 | Instructor - Chair Yoga Arthritis Wed | 1/31/2024 | \$ 150.00 | 2/12/2024 | 182446 |
| Recreation Program Expense | Mary Pat Hartline | 1/11/2024 | Instructor - Pure Stretch Mon | 1/31/2024 | \$ 90.00 | 2/12/2024 | 182446 |
| Recreation Program Expense | Mason Paul | 1/3/2024 | Instructor - Rockin New Years Eve Bash | 1/31/2024 | \$ 120.00 | 2/12/2024 | 182447 |
| Recreation Program Expense | Mason Paul | 1/4/2024 | Instructor - Rockin' New Years Eve Bash | 1/31/2024 | \$ 120.00 | 2/12/2024 | 182447 |
| Recreation Program Expense | Mason Paul | 1/9/2024 | Instructor - Kids Night Out | 1/31/2024 | \$ 45.00 | 2/12/2024 | 182447 |
| Recreation Program Expense | Maura Riscavage | 1/3/2024 | Instructor - Rockin New Years Eve Bash | 1/31/2024 | \$ 143.00 | 2/12/2024 | 182448 |
| Recreation Program Expense | Maxwell J Carfrey | 1/18/2024 | Rentals | 1/31/2024 | \$ 112.00 | 2/12/2024 | 182449 |
| Recreation Program Expense | Pi-Chi Yang | 1/17/2024 | Instructor - Adult Ballet | 1/31/2024 | \$ 140.00 | 2/12/2024 | 182475 |
| Recreation Program Expense | PPS Print Solutions | 12/21/2023 | Winter 2023 HavaGood Times Newsletter | 1/31/2024 | \$ 11,592.65 | 2/12/2024 | 182479 |
| Recreation Program Expense | Robert Rinaldi | 1/25/2024 | Instructor - Little Explorers | 1/31/2024 | \$ 56.00 | 2/12/2024 | 182484 |
| Recreation Program Expense | Sandi Kirschner | 1/11/2024 | Instructor - Gentle Stretch & Tone Wed | 1/31/2024 | \$ 175.00 | 2/12/2024 | 182485 |
| Recreation Program Expense | Sandy McGuire | 1/11/2024 | Instructor - Barre Thu | 1/31/2024 | \$ 160.00 | 2/12/2024 | 182486 |
| Recreation Program Expense | Sandy McGuire | 1/11/2024 | Instructor - Cycle Sat | 1/31/2024 | \$ 160.00 | 2/12/2024 | 182486 |
| Recreation Program Expense | Sandy McGuire | 1/11/2024 | Instructor - Cycle Tue | 1/31/2024 | \$ 200.00 | 2/12/2024 | 182486 |
| Recreation Program Expense | School District of Haverford Township | 1/31/2024 | Manoa ES Gym Rental | 1/31/2024 | \$ 300.00 | 2/12/2024 | 182487 |
| Recreation Program Expense | School District of Haverford Township | 1/31/2024 | Manoa ES Gym Rental | 1/31/2024 | \$ 480.00 | 2/12/2024 | 182487 |

| | | | | | | | |
|----------------------------|--|------------|---|-----------|--------------|-----------|--------|
| Recreation Program Expense | School District of Haverford Township | 1/31/2024 | Manoa ES Gym Rental | 1/31/2024 | \$ 540.00 | 2/12/2024 | 182487 |
| Recreation Program Expense | School District of Haverford Township | 1/31/2024 | Manoa ES Gym Rental | 1/31/2024 | \$ 720.00 | 2/12/2024 | 182487 |
| Recreation Program Expense | School District of Haverford Township | 1/31/2024 | Coopertown ES Gym Rental | 1/31/2024 | \$ 760.00 | 2/12/2024 | 182487 |
| Recreation Program Expense | School District of Haverford Township | 1/31/2024 | Coopertown ES Gym Rental | 1/31/2024 | \$ 800.00 | 2/12/2024 | 182487 |
| Recreation Program Expense | School District of Haverford Township | 1/31/2024 | Chestnutwold ES Gym Rental | 1/31/2024 | \$ 660.00 | 2/12/2024 | 182487 |
| Recreation Program Expense | School District of Haverford Township | 1/31/2024 | Chestnutwold ES Gym Rental | 1/31/2024 | \$ 800.00 | 2/12/2024 | 182487 |
| Recreation Program Expense | School District of Haverford Township | 1/31/2024 | Manoa ES Gym Rental | 1/31/2024 | \$ 480.00 | 2/12/2024 | 182487 |
| Recreation Program Expense | School District of Haverford Township | 1/31/2024 | Lynnewood ES Gym Rental | 1/31/2024 | \$ 5,250.00 | 2/12/2024 | 182487 |
| Recreation Program Expense | Spectrum Letterbox | 1/1/2024 | Havagood Times Winter/Spring 2024 | 1/31/2024 | \$ 1,795.00 | 2/12/2024 | 182493 |
| Recreation Program Expense | Spike's Trophies Limited | 11/11/2023 | (32) Medals - Chilly Trail Run | 1/31/2024 | \$ 131.40 | 2/12/2024 | 182494 |
| Recreation Program Expense | Staci Gillespie | 1/31/2024 | Instructor - Havertown Hoops | 1/31/2024 | \$ 1,005.00 | 2/12/2024 | 182496 |
| Recreation Program Expense | William McKee | 1/31/2024 | Scorekeeper | 1/31/2024 | \$ 238.00 | 2/12/2024 | 182516 |
| Total 01450922002: | | | | | \$ 43,642.87 | | |
| 1450923202 | | | | | | | |
| Operating Expenses - CREC | Apex Elevator Inspection & Testing LLC | 12/29/2023 | Routine Inspection - CREC | 1/31/2024 | \$ 60.00 | 2/12/2024 | 182358 |
| Operating Expenses - CREC | Franklin Cleaning Equip & Supply Co | 1/9/2024 | Brush Assembly, Bearing Kit | 1/31/2024 | \$ 293.86 | 2/12/2024 | 182408 |
| Operating Expenses - CREC | Hillyard /Delaware Valley Inc | 1/12/2024 | (2) Scrubbing Pads | 1/31/2024 | \$ 108.40 | 2/12/2024 | 182422 |
| Operating Expenses - CREC | Omer's Garden Center | 12/13/2023 | (2) Douglas Fir | 1/31/2024 | \$ 140.00 | 2/12/2024 | 182464 |
| Operating Expenses - CREC | Sinclair Exterminating Inc | 12/31/2023 | Exterminating - CREC | 1/31/2024 | \$ 195.00 | 2/12/2024 | 182491 |
| Operating Expenses - CREC | T. Frank McCall's, Inc | 1/10/2024 | Maintenance Items | 1/31/2024 | \$ 1,173.15 | 2/12/2024 | 182499 |
| Operating Expenses - CREC | T. Frank McCall's, Inc | 1/16/2024 | Maintenance Items | 1/31/2024 | \$ 230.19 | 2/12/2024 | 182499 |
| Operating Expenses - CREC | T. Frank McCall's, Inc | 1/25/2024 | Maintenance Items | 1/31/2024 | \$ 128.68 | 2/12/2024 | 182499 |
| Operating Expenses - CREC | T. Frank McCall's, Inc | 1/30/2024 | Maintenance Items | 1/31/2024 | \$ 123.09 | 2/12/2024 | 182499 |
| Operating Expenses - CREC | Tustin Water Solutions LLC | 1/4/2024 | Water Treatment Maint Agreeme | 1/31/2024 | \$ 381.00 | 2/12/2024 | 182511 |
| Operating Expenses - CREC | W. B. Mason Co, Inc. | 12/1/2023 | Cleaning Supplies | 1/31/2024 | \$ 140.00 | 2/12/2024 | 182515 |
| Total 01450923202: | | | | | \$ 2,973.37 | | |
| 1451150002 | | | | | | | |
| Life Insurance | North American Benefits Company | 1/22/2024 | Group Term Life Insurance | 1/31/2024 | \$ 56.40 | 1/30/2024 | 182320 |
| Total 01451150002: | | | | | \$ 56.40 | | |
| 1451150502 | | | | | | | |
| Health Benefits | DelCo Public Schools Healthcare Trst | 1/2/2024 | Health Benefits | 1/31/2024 | \$ 6,099.61 | 1/16/2024 | 182272 |
| Total 01451150502: | | | | | \$ 6,099.61 | | |
| 1451151002 | | | | | | | |
| Rx/Dental/Vision/LTD | Express Scripts Inc | 1/12/2024 | Prescription Benefits | 1/31/2024 | \$ 112.44 | 1/12/2024 | 426 |
| Rx/Dental/Vision/LTD | Express Scripts Inc | 1/22/2024 | Prescription Benefits | 1/31/2024 | \$ 165.88 | 1/30/2024 | 430 |
| Rx/Dental/Vision/LTD | North American Benefits Company | 1/22/2024 | Long Term Civilian Disability Insurance | 2/29/2024 | \$ 94.24 | 2/6/2024 | 182337 |
| Total 01451151002: | | | | | \$ 372.56 | | |
| 1451152002 | | | | | | | |
| Workers Compensation | Arthur J Gallagher Risk Mgmt Serv Inc | 1/8/2024 | 2022 WC Audit | 1/31/2024 | \$ 420.12 | 1/16/2024 | 182263 |
| Total 01451152002: | | | | | \$ 420.12 | | |
| 1451200002 | | | | | | | |
| Miscellaneous Expense | Rick Turnbull | 1/10/2024 | Skate Guard Holiday Lunch | 1/31/2024 | \$ 22.26 | 1/16/2024 | 182290 |
| Total 01451200002: | | | | | \$ 22.26 | | |
| 1451200202 | | | | | | | |
| Office Supplies | Office Basics, Inc | 1/18/2024 | Office Supplies | 1/31/2024 | \$ 75.95 | 2/12/2024 | 182462 |
| Total 01451200202: | | | | | \$ 75.95 | | |
| 1451201302 | | | | | | | |
| Utilities | Peco Energy | 12/28/2023 | 1002 Darby Rd - Rear | 1/31/2024 | \$ 1,733.07 | 1/9/2024 | 182256 |
| Utilities | Peco Energy | 12/28/2023 | Darby Rd & N Manoa Rd - Skatium | 1/31/2024 | \$ 12,431.63 | 1/9/2024 | 182256 |
| Utilities | Aqua Pennsylvania | 1/16/2024 | 1020 Darby Rd - Skatium | 1/31/2024 | \$ 1,900.44 | 1/23/2024 | 182294 |
| Utilities | Constellation NewEnergy Gas Division LLC | 1/25/2024 | Natural Gas - 1002 Darby Rd | 1/31/2024 | \$ 2,432.52 | 1/30/2024 | 182315 |
| Utilities | Peco Energy | 1/29/2024 | 1002 Darby Rd - Rear | 2/29/2024 | \$ 2,036.77 | 2/6/2024 | 182339 |
| Utilities | Peco Energy | 1/29/2024 | Darby Rd & N Manoa Rd - Skatium | 2/29/2024 | \$ 11,417.18 | 2/6/2024 | 182339 |
| Total 01451201302: | | | | | \$ 31,951.61 | | |
| 1451210102 | | | | | | | |
| Postage Expense | FP Finance Program | 12/27/2023 | Postage Meter Lease | 1/31/2024 | \$ 3.75 | 1/9/2024 | 182250 |
| Postage Expense | FP Finance Program | 1/29/2024 | Postage Meter Lease | 2/29/2024 | \$ 3.75 | 2/6/2024 | 182335 |
| Total 01451210102: | | | | | \$ 7.50 | | |
| 1451280302 | | | | | | | |

| | | | | | | | | |
|-----------------------------|---------------------------------------|------------|--|-----------|----|-----------|-----------|--------|
| Uniforms Regular | Flocco Inc | 8/30/2023 | Work Boots | 1/31/2024 | \$ | 120.00 | 1/16/2024 | 182275 |
| Total 01451280302: | | | | | \$ | 120.00 | | |
| 1451300002 | | | | | | | | |
| Communications | Comcast | 1/16/2024 | Cable Service - 1018 Darby Rd | 1/31/2024 | \$ | 275.26 | 1/23/2024 | 182299 |
| Communications | AT & T Mobility | 1/16/2024 | Cellular Service | 2/29/2024 | \$ | 89.46 | 2/6/2024 | 182331 |
| Total 01451300002: | | | | | \$ | 364.72 | | |
| 1451400002 | | | | | | | | |
| Copier Lease/Maintenance | Toshiba America Business Solutions | 12/25/2023 | Copier Maintenance | 1/31/2024 | \$ | 4.23 | 1/9/2024 | 182258 |
| Copier Lease/Maintenance | Toshiba Financial Service | 12/28/2023 | Copier Lease | 1/31/2024 | \$ | 134.19 | 1/9/2024 | 182259 |
| Copier Lease/Maintenance | Toshiba Financial Service | 1/23/2024 | Copier Lease | 1/31/2024 | \$ | 134.19 | 1/30/2024 | 182326 |
| Copier Lease/Maintenance | Toshiba America Business Solutions | 1/22/2024 | Copier Maintenance | 2/29/2024 | \$ | 2.99 | 2/6/2024 | 182344 |
| Total 01451400002: | | | | | \$ | 275.60 | | |
| 1451430002 | | | | | | | | |
| Maintenance & Repairs | Lowe's | 12/4/2023 | Oil-Based Polyurethane, (10) Paint Brushes, Roller | 1/31/2024 | \$ | 115.33 | 1/16/2024 | 182284 |
| Maintenance & Repairs | T. Frank McCall's, Inc | 11/30/2023 | Maintenance Items | 1/31/2024 | \$ | 50.38 | 1/16/2024 | 182292 |
| Maintenance & Repairs | Daktronics Inc | 1/27/2024 | (2) AMB 7 Seg Discrete LED | 1/31/2024 | \$ | 250.00 | 2/12/2024 | 182385 |
| Maintenance & Repairs | Elliott-Lewis | 1/25/2024 | Preventive Maintenance | 1/31/2024 | \$ | 2,700.00 | 2/12/2024 | 182401 |
| Maintenance & Repairs | Hill Manufacturing Company Inc | 12/14/2023 | (12) Wall Blocks | 1/31/2024 | \$ | 122.27 | 2/12/2024 | 182421 |
| Maintenance & Repairs | T. Frank McCall's, Inc | 12/21/2023 | Maintenance Items | 1/31/2024 | \$ | 98.60 | 2/12/2024 | 182499 |
| Maintenance & Repairs | Tustin Mechanical Services LLC | 12/28/2023 | Compressor Repair - Skatium | 1/31/2024 | \$ | 541.50 | 2/12/2024 | 182510 |
| Maintenance & Repairs | Tustin Mechanical Services LLC | 1/17/2024 | Service - Bolier | 1/31/2024 | \$ | 239.32 | 2/12/2024 | 182510 |
| Total 01451430002: | | | | | \$ | 4,117.40 | | |
| 1451511002 | | | | | | | | |
| Zamboni Gas/Maint/Insurance | Arthur J Gallagher Risk Mgmt Serv Inc | 12/18/2023 | P & C Insurance Premium â€" 3rd Installment | 1/31/2024 | \$ | 571.48 | 1/30/2024 | 182312 |
| Zamboni Gas/Maint/Insurance | J & C Ice Technologies Inc | 1/16/2024 | Fuel Pump, Speed Sensor Z-1 | 1/31/2024 | \$ | 556.56 | 2/12/2024 | 182427 |
| Zamboni Gas/Maint/Insurance | Petroleum Traders Corp | 12/27/2023 | Unleaded | 1/31/2024 | \$ | 48.16 | 2/12/2024 | 182473 |
| Zamboni Gas/Maint/Insurance | Petroleum Traders Corp | 1/19/2024 | Unleaded | 1/31/2024 | \$ | 52.05 | 2/12/2024 | 182473 |
| Zamboni Gas/Maint/Insurance | Tri-State/Ace Knife Grinding Corp | 12/20/2023 | Blade sharpening | 1/31/2024 | \$ | 262.00 | 2/12/2024 | 182506 |
| Total 01451511002: | | | | | \$ | 1,490.25 | | |
| 1451511502 | | | | | | | | |
| Purchase Of Rental Skates | Riedell Shoes Inc | 12/27/2023 | (21) Skates, (48) Laces | 1/31/2024 | \$ | 3,712.35 | 2/12/2024 | 182483 |
| Total 01451511502: | | | | | \$ | 3,712.35 | | |
| 1451511602 | | | | | | | | |
| Instructor Expense | Cassandra Hawks | 2/1/2024 | Instructor | 1/31/2024 | \$ | 216.00 | 2/12/2024 | 182376 |
| Instructor Expense | Dean S Boornazian | 2/1/2024 | Instructor | 1/31/2024 | \$ | 624.00 | 2/12/2024 | 182388 |
| Instructor Expense | Jill Cosgrove | 2/1/2024 | Instructor | 1/31/2024 | \$ | 324.00 | 2/12/2024 | 182430 |
| Instructor Expense | Oleg Altukhov | 2/1/2024 | Instructor | 1/31/2024 | \$ | 324.00 | 2/12/2024 | 182463 |
| Total 01451511602: | | | | | \$ | 1,488.00 | | |
| 1451511702 | | | | | | | | |
| Rink Equipment | Rick Turnbull | 1/10/2024 | Broom, Grease Gun | 1/31/2024 | \$ | 90.75 | 1/16/2024 | 182290 |
| Rink Equipment | Fisher's Ace Hardware | 12/28/2023 | Drill | 1/31/2024 | \$ | 139.00 | 2/12/2024 | 182405 |
| Total 01451511702: | | | | | \$ | 229.75 | | |
| 1451522802 | | | | | | | | |
| Gate Sharing Expense | St Joseph's Preparatory School | 1/8/2024 | Prep Hockey PTR - SJP Gate Split Pink the Rink | 1/31/2024 | \$ | 980.00 | 1/16/2024 | 182291 |
| Total 01451522802: | | | | | \$ | 980.00 | | |
| 1454150002 | | | | | | | | |
| Life Insurance | North American Benefits Company | 1/22/2024 | Group Term Life Insurance | 1/31/2024 | \$ | 78.60 | 1/30/2024 | 182320 |
| Total 01454150002: | | | | | \$ | 78.60 | | |
| 1454150502 | | | | | | | | |
| Health Benefits | DelCo Public Schools Healthcare Trst | 1/2/2024 | Health Benefits | 1/31/2024 | \$ | 21,100.33 | 1/16/2024 | 182272 |
| Total 01454150502: | | | | | \$ | 21,100.33 | | |
| 1454151002 | | | | | | | | |
| Rx/Dental/Vision/LTD | Express Scripts Inc | 1/12/2024 | Prescription Benefits | 1/31/2024 | \$ | 22.01 | 1/12/2024 | 426 |
| Rx/Dental/Vision/LTD | Express Scripts Inc | 1/22/2024 | Prescription Benefits | 1/31/2024 | \$ | 87.35 | 1/30/2024 | 430 |
| Rx/Dental/Vision/LTD | North American Benefits Company | 1/22/2024 | Long Term Civilian Disability Insurance | 2/29/2024 | \$ | 194.10 | 2/6/2024 | 182337 |
| Total 01454151002: | | | | | \$ | 303.46 | | |
| 1454152002 | | | | | | | | |
| Workers Compensation | Arthur J Gallagher Risk Mgmt Serv Inc | 1/8/2024 | 2022 WC Audit | 1/31/2024 | \$ | 443.46 | 1/16/2024 | 182263 |
| Total 01454152002: | | | | | \$ | 443.46 | | |

| | | | | | | | | |
|-----------------------|----------------------------|------------|---------------------------------------|-----------|----|----------|-----------|--------|
| 1454200002 | | | | | | | | |
| Miscellaneous Expense | ReadyRefresh by Nestle Inc | 1/6/2024 | Water Service | 1/31/2024 | \$ | 1.99 | 1/16/2024 | 182289 |
| Miscellaneous Expense | ReadyRefresh by Nestle Inc | 1/6/2024 | Water Service | 1/31/2024 | \$ | 1.99 | 1/30/2024 | 182324 |
| Miscellaneous Expense | Commonwealth of PA | 12/31/2023 | Pesticide License - P Hickman | 1/31/2024 | \$ | 10.00 | 2/12/2024 | 182382 |
| Miscellaneous Expense | Pennoni Associates, Inc | 2/1/2024 | Noise Monitoring @ Township Parks | 1/31/2024 | \$ | 1,239.22 | 2/12/2024 | 182469 |
| Total 01454200002: | | | | | \$ | 1,253.20 | | |
| 1454200502 | | | | | | | | |
| Computer Expense | Noratek Solutions Inc | 1/9/2024 | Annual Playground Inspection Software | 1/31/2024 | \$ | 3,307.50 | 2/12/2024 | 182459 |
| Total 014542000502: | | | | | \$ | 3,307.50 | | |
| 1454201302 | | | | | | | | |
| Utilities for Parks | Aqua Pennsylvania | 12/20/2023 | 519 Hillside Ave - Hilltop | 1/31/2024 | \$ | 52.96 | 1/9/2024 | 182244 |
| Utilities for Parks | Aqua Pennsylvania | 12/20/2023 | 304 Oxford Hill Ln - Westgate | 1/31/2024 | \$ | 40.54 | 1/9/2024 | 182244 |
| Utilities for Parks | Aqua Pennsylvania | 12/20/2023 | 1426 Windsor Park Ln - Westgate | 1/31/2024 | \$ | 176.07 | 1/9/2024 | 182244 |
| Utilities for Parks | Peco Energy | 12/28/2023 | 534 Central Ave - Hilltop Club Hse | 1/31/2024 | \$ | 170.55 | 1/9/2024 | 182256 |
| Utilities for Parks | Peco Energy | 12/28/2023 | 534 Central Ave | 1/31/2024 | \$ | 34.15 | 1/9/2024 | 182256 |
| Utilities for Parks | Peco Energy | 12/28/2023 | 1002 Darby Rd - Field Lighting | 1/31/2024 | \$ | 537.10 | 1/9/2024 | 182256 |
| Utilities for Parks | Peco Energy | 12/28/2023 | Burmout Rd - Warrior Rd | 1/31/2024 | \$ | 75.04 | 1/9/2024 | 182256 |
| Utilities for Parks | Peco Energy | 12/28/2023 | 600 Glendale Rd - Merry Place | 1/31/2024 | \$ | 641.96 | 1/9/2024 | 182256 |
| Utilities for Parks | Peco Energy | 12/28/2023 | 200 Darby Rd - Llanerch Crossing | 1/31/2024 | \$ | 119.47 | 1/9/2024 | 182256 |
| Utilities for Parks | Peco Energy | 12/28/2023 | Grasslyn Av - Grasslyn Park | 1/31/2024 | \$ | 16.44 | 1/9/2024 | 182256 |
| Utilities for Parks | Peco Energy | 12/28/2023 | Parkview Dr - Public Light | 1/31/2024 | \$ | 2,914.65 | 1/9/2024 | 182256 |
| Utilities for Parks | Peco Energy | 12/28/2023 | 521 Hillside Ave - Hilltop Park | 1/31/2024 | \$ | 25.70 | 1/9/2024 | 182256 |
| Utilities for Parks | Peco Energy | 12/28/2023 | Hillcrest Rd - Rear @ Woodleigh Rd | 1/31/2024 | \$ | 48.86 | 1/9/2024 | 182256 |
| Utilities for Parks | Peco Energy | 12/28/2023 | Preston Av & Railroad | 1/31/2024 | \$ | 14.74 | 1/9/2024 | 182256 |
| Utilities for Parks | Peco Energy | 12/28/2023 | Rose Tree Ln & Oxford Hill Ln | 1/31/2024 | \$ | 11.02 | 1/9/2024 | 182256 |
| Utilities for Parks | Peco Energy | 12/28/2023 | 311 Highland Av | 1/31/2024 | \$ | 14.55 | 1/9/2024 | 182256 |
| Utilities for Parks | Peco Energy | 12/28/2023 | 672 Ardmore Av | 1/31/2024 | \$ | 146.26 | 1/9/2024 | 182256 |
| Utilities for Parks | Peco Energy | 12/28/2023 | Veterans Field 20 W Manoa Rd | 1/31/2024 | \$ | 11.02 | 1/9/2024 | 182256 |
| Utilities for Parks | Peco Energy | 12/28/2023 | Washington Av - Manoa Rd | 1/31/2024 | \$ | 56.53 | 1/9/2024 | 182256 |
| Utilities for Parks | Peco Energy | 12/28/2023 | Washington Av | 1/31/2024 | \$ | 30.12 | 1/9/2024 | 182256 |
| Utilities for Parks | Peco Energy | 12/28/2023 | Raymond Dr - Genthart | 1/31/2024 | \$ | 29.97 | 1/9/2024 | 182256 |
| Utilities for Parks | Aqua Pennsylvania | 1/16/2024 | 514 St Albans Rd - Grange Field | 1/31/2024 | \$ | 35.02 | 1/23/2024 | 182294 |
| Utilities for Parks | Aqua Pennsylvania | 1/16/2024 | 906 Powder Mill Rd - Powder Mill | 1/31/2024 | \$ | 35.99 | 1/23/2024 | 182294 |
| Utilities for Parks | Aqua Pennsylvania | 1/16/2024 | 1845 Karakung Dr - Karakung | 1/31/2024 | \$ | 20.97 | 1/23/2024 | 182294 |
| Utilities for Parks | Aqua Pennsylvania | 1/16/2024 | 1623 Pelham Rd - Karakung | 1/31/2024 | \$ | 20.97 | 1/23/2024 | 182294 |
| Utilities for Parks | Aqua Pennsylvania | 1/16/2024 | 705 Myrtle Ave - Karakung | 1/31/2024 | \$ | 35.99 | 1/23/2024 | 182294 |
| Utilities for Parks | Aqua Pennsylvania | 1/16/2024 | 2200 Grasslyn Ave - Grasslyn | 1/31/2024 | \$ | 20.97 | 1/23/2024 | 182294 |
| Utilities for Parks | Aqua Pennsylvania | 1/23/2024 | 605 Washington Ave - Veterans | 1/31/2024 | \$ | 35.99 | 1/30/2024 | 182311 |
| Utilities for Parks | Aqua Pennsylvania | 1/22/2024 | 519 Hillside Ave - Hilltop | 1/31/2024 | \$ | 38.69 | 1/30/2024 | 182311 |
| Utilities for Parks | Aqua Pennsylvania | 1/22/2024 | 304 Oxford Hill Ln - Westgate | 1/31/2024 | \$ | 21.34 | 1/30/2024 | 182311 |
| Utilities for Parks | Aqua Pennsylvania | 1/17/2024 | ES Merrybrook Rd - Paddock | 1/31/2024 | \$ | 31.00 | 1/30/2024 | 182311 |
| Utilities for Parks | Aqua Pennsylvania | 1/17/2024 | 2512 Wynnefield Dr - Merwood | 1/31/2024 | \$ | 35.99 | 1/30/2024 | 182311 |
| Utilities for Parks | Aqua Pennsylvania | 1/17/2024 | 660 Ardmore Ave - Elwell | 1/31/2024 | \$ | 20.97 | 1/30/2024 | 182311 |
| Utilities for Parks | Aqua Pennsylvania | 1/17/2024 | 721 Railroad Ave - Preston | 1/31/2024 | \$ | 20.97 | 1/30/2024 | 182311 |
| Utilities for Parks | Aqua Pennsylvania | 1/17/2024 | 600 Dayton Rd - Polo | 1/31/2024 | \$ | 20.97 | 1/30/2024 | 182311 |
| Utilities for Parks | Aqua Pennsylvania | 1/22/2024 | 1426 Windsor Park Ln - Westgate | 1/31/2024 | \$ | 104.31 | 1/30/2024 | 182311 |
| Utilities for Parks | Aqua Pennsylvania | 1/17/2024 | 3500 Darby Rd - Lot A-Sprinkler | 1/31/2024 | \$ | 608.20 | 1/30/2024 | 182311 |
| Utilities for Parks | Aqua Pennsylvania | 1/17/2024 | 3500 Darby Rd - Lot B-Sprinkler | 1/31/2024 | \$ | 167.67 | 1/30/2024 | 182311 |
| Utilities for Parks | Aqua Pennsylvania | 1/17/2024 | 955 Railroad Av - Polo | 1/31/2024 | \$ | 117.78 | 1/30/2024 | 182311 |
| Utilities for Parks | Aqua Pennsylvania | 1/17/2024 | 9001 Parkview Dr - Dog Park Line | 1/31/2024 | \$ | 20.97 | 1/30/2024 | 182311 |
| Utilities for Parks | Aqua Pennsylvania | 1/17/2024 | 422 W Hathaway Ln - Merwood Park | 1/31/2024 | \$ | 45.33 | 1/30/2024 | 182311 |
| Utilities for Parks | Peco Energy | 1/29/2024 | 534 Central Ave - Hilltop Club Hse | 2/29/2024 | \$ | 116.43 | 2/6/2024 | 182339 |
| Utilities for Parks | Peco Energy | 1/29/2024 | 534 Central Ave | 2/29/2024 | \$ | 35.00 | 2/6/2024 | 182339 |
| Utilities for Parks | Peco Energy | 1/29/2024 | 1002 Darby Rd - Field Lighting | 2/29/2024 | \$ | 280.42 | 2/6/2024 | 182339 |
| Utilities for Parks | Peco Energy | 1/29/2024 | Burmout Rd - Warrior Rd | 2/29/2024 | \$ | 37.18 | 2/6/2024 | 182339 |
| Utilities for Parks | Peco Energy | 1/29/2024 | 600 Glendale Rd - Merry Place | 2/29/2024 | \$ | 671.86 | 2/6/2024 | 182339 |
| Utilities for Parks | Peco Energy | 1/29/2024 | 200 Darby Rd - Llanerch Crossing | 2/29/2024 | \$ | 78.41 | 2/6/2024 | 182339 |
| Utilities for Parks | Peco Energy | 1/29/2024 | Grasslyn Av - Grasslyn Park | 2/29/2024 | \$ | 16.50 | 2/6/2024 | 182339 |
| Utilities for Parks | Peco Energy | 1/29/2024 | Parkview Dr - Public Light | 2/29/2024 | \$ | 2,316.54 | 2/6/2024 | 182339 |

| | | | | | | | |
|-----------------------------|---------------------------------------|------------|--|-----------|-----------------|-----------|-------|
| Engineering Fees | Pennoni Associates, Inc | 2/1/2024 | Landfill @ Maintenance Yard | 1/31/2024 | \$ 610.00 | 2/12/2024 | 19599 |
| Total 08429290402: | | | | | \$ 610.00 | | |
| 8429300002 | | | | | | | |
| Communications | AT & T Mobility | 1/16/2024 | Cellular Service | 2/29/2024 | \$ 89.46 | 2/6/2024 | 19587 |
| Communications | Pennsylvania One Call System Inc | 12/31/2023 | Emergency phone srvc | 1/31/2024 | \$ 199.30 | 2/12/2024 | 19600 |
| Total 08429300002: | | | | | \$ 288.76 | | |
| 8429410802 | | | | | | | |
| General Liability Insurance | Arthur J Gallagher Risk Mgmt Serv Inc | 12/18/2023 | P & C Insurance Premium â€“ 3rd Installment | 1/31/2024 | \$ 2,949.50 | 1/30/2024 | 19585 |
| Total 08429410802: | | | | | \$ 2,949.50 | | |
| 8429411702 | | | | | | | |
| Vehicle Insurance | Arthur J Gallagher Risk Mgmt Serv Inc | 12/18/2023 | P & C Insurance Premium â€“ 3rd Installment | 1/31/2024 | \$ 3,200.26 | 1/30/2024 | 19585 |
| Total 08429411702: | | | | | \$ 3,200.26 | | |
| 8429510002 | | | | | | | |
| Vehicle Fuel | Petroleum Traders Corp | 12/27/2023 | Unleaded | 1/31/2024 | \$ 888.55 | 2/12/2024 | 19601 |
| Vehicle Fuel | Petroleum Traders Corp | 12/27/2023 | Unleaded | 1/31/2024 | \$ 652.35 | 2/12/2024 | 19601 |
| Vehicle Fuel | Petroleum Traders Corp | 1/19/2024 | Unleaded | 1/31/2024 | \$ 771.57 | 2/12/2024 | 19601 |
| Vehicle Fuel | Petroleum Traders Corp | 1/19/2024 | Unleaded | 1/31/2024 | \$ 566.47 | 2/12/2024 | 19601 |
| Vehicle Fuel | School District of Haverford Township | 1/29/2024 | Diesel Fuel | 1/31/2024 | \$ 480.51 | 2/12/2024 | 19602 |
| Total 08429510002: | | | | | \$ 3,359.45 | | |
| 8429510702 | | | | | | | |
| Vehicle Maintenance | H A DeHart & Son | 1/10/2024 | Hose Assy SE-72 | 1/31/2024 | \$ 333.90 | 2/12/2024 | 19594 |
| Vehicle Maintenance | Imperial Supplies LLC | 1/2/2024 | (4) Hand Cleaners, ABS Coil, (20) Cut Off Wheels | 1/31/2024 | \$ 438.78 | 2/12/2024 | 19596 |
| Vehicle Maintenance | Linde Gas & Equipment Inc | 1/4/2024 | Cylinder Rental | 1/31/2024 | \$ 266.52 | 2/12/2024 | 19598 |
| Total 08429510702: | | | | | \$ 1,039.20 | | |
| 8429600002 | | | | | | | |
| Minor Equipment | Linde Gas & Equipment Inc | 1/23/2024 | Cylinder Rental | 1/31/2024 | \$ 220.59 | 2/12/2024 | 19598 |
| Total 08429600002: | | | | | \$ 220.59 | | |
| Total Sewer Fund:: | | | | | \$ 214,974.93 | | |
| Grand Totals: | | | | | \$ 3,048,768.23 | | |

Haverford Township
 Check Register - January 9, 2024 thru February 12, 2024
 (Formatted for ADA Accessibility)

| Check Issue Date | Check Number | Payee | Amount |
|----------------------------------|--------------|---------------------------------------|---------------|
| American Rescue Plan - PLGIT | | | |
| 1/9/2024 | 7091 | Christine Fanelli | \$ 500.00 |
| 1/16/2024 | 7094 | Julio S. Paz Y Mino | \$ 500.00 |
| 1/16/2024 | 7095 | LogoWear House Inc | \$ 980.00 |
| 1/23/2024 | 7096 | Edward Konieczny | \$ 500.00 |
| 1/29/2024 | 7097 | Maryann Dugan | \$ - V |
| 1/29/2024 | 7098 | Scott Selkowitz | \$ - V |
| 1/30/2024 | 7099 | Maryann Dugan | \$ 500.00 |
| 1/30/2024 | 7100 | Scott Selkowitz | \$ 80.62 |
| 2/6/2024 | 7101 | Dolores E Brough | \$ 500.00 |
| 2/12/2024 | 7102 | All Seasons Landscaping Co. Inc. | \$ 21,490.00 |
| 2/12/2024 | 7103 | Element Environmental Solutions Inc | \$ 2,665.00 |
| 2/12/2024 | 7104 | FencCo Inc | \$ 11,000.00 |
| 2/12/2024 | 7105 | N Abbonizio Contractors, Inc | \$ 23,516.08 |
| 2/12/2024 | 7106 | Penndot | \$ 140.00 |
| 2/12/2024 | 7107 | Pennoni Associates, Inc | \$ 20,893.35 |
| Total American Rescue Plan Fund: | | | \$ 83,265.05 |
| 2018 GO Bond - PLGIT | | | |
| 2/12/2024 | 1138 | Pennoni Associates, Inc | \$ 3,441.25 M |
| 2023 GO Bond Series A - PLGIT | | | |
| 1/16/2024 | 8055 | Flag Products Inc | \$ 3,589.50 |
| 2/12/2024 | 8056 | AJM Electric, Inc | \$ 17,775.00 |
| 2/12/2024 | 8057 | Bernardon Architects | \$ 6,241.36 |
| 2/12/2024 | 8058 | Bristol Environmental inc | \$ 12,300.00 |
| 2/12/2024 | 8059 | C.B. Development Services, Inc | \$ 63,900.00 |
| 2/12/2024 | 8060 | Corcoran Drilling Co Inc | \$ 1,950.00 |
| 2/12/2024 | 8061 | David Blackmore & Associates Inc | \$ 4,698.48 |
| 2/12/2024 | 8062 | Delaware County Intermediate Unit | \$ 12,754.08 |
| 2/12/2024 | 8063 | Dolan Mechanical, Inc | \$ 124,135.20 |
| 2/12/2024 | 8064 | Element Environmental Solutions Inc | \$ 8,607.85 |
| 2/12/2024 | 8065 | Excel Elevator & Escalator LLC | \$ 850.00 |
| 2/12/2024 | 8066 | Keystone Municipal Services, Inc | \$ 37.50 |
| 2/12/2024 | 8067 | Pennoni Associates, Inc | \$ 848.75 |
| 2/12/2024 | 8068 | Rycon Construction, Inc | \$ 164,159.78 |
| 2/12/2024 | 8069 | Spidernet Technical Consulting, LLC | \$ 11,725.65 |
| 2023 GO Bond Series B - PLGIT | | | |
| 2/12/2024 | 7016 | McCloskey Mechanical Contractors, Inc | \$ 67,321.80 |
| 2/12/2024 | 7017 | Pennoni Associates, Inc | \$ 5,806.75 |
| 2/12/2024 | 7018 | Schipsi Electric, LLC | \$ 5,492.70 |
| Capital Projects - PLGIT | | | |
| 1/16/2024 | 1415 | Richard E Pierson Construction Inc | \$ 96,590.05 |
| 1/16/2024 | 1416 | Traffic Planning and Design, Inc | \$ 17,420.30 |
| 2/12/2024 | 1417 | CDW Government Inc | \$ 13,115.50 |
| 2/12/2024 | 1418 | Herbert Rowland and Grubic, Inc | \$ 3,757.22 |
| 2/12/2024 | 1419 | Michael Baker International, Inc | \$ 12,364.98 |
| 2/12/2024 | 1420 | Pennoni Associates, Inc | \$ 8,173.75 |

| | | | | |
|---------------------|------|--|----|------------|
| 2/12/2024 | 1421 | Signal Service, Inc | \$ | 14,887.40 |
| 2/12/2024 | 1422 | Wiss, Janney, Elstner Associates, Inc. | \$ | 1,797.40 |
| Total Capital Fund: | | | \$ | 683,742.25 |

CDBG Cash - Operating

| | | | | |
|------------------------|------|-----------------------------------|----|-----------|
| 1/9/2024 | 4770 | Pennoni Associates, Inc | \$ | 981.60 |
| 1/9/2024 | 4771 | S.B. Conrad, Inc | \$ | 7,040.00 |
| 2/12/2024 | 4772 | AJP Contractors Inc | \$ | 2,700.00 |
| 2/12/2024 | 4773 | Anthony J Dunleavy Assoc Inc | \$ | 25,000.00 |
| 2/12/2024 | 4774 | Leadco Environmental Services Inc | \$ | 1,759.00 |
| 2/12/2024 | 4775 | Pennoni Associates, Inc | \$ | 1,351.15 |
| 2/12/2024 | 4776 | Surrey Services for Seniors | \$ | 5,513.00 |
| Total CDBG Grant Fund: | | | \$ | 44,344.81 |

General Operating

| | | | | | |
|-----------|--------|---|----|------------|---|
| 1/12/2024 | 424 | PA Dept of Labor & Industry | \$ | 2,782.19 | M |
| 1/12/2024 | 428 | Arbiter Sports | \$ | 5,000.00 | M |
| 1/17/2024 | 182093 | Plant Signs | \$ | (1,437.47) | V |
| 1/24/2024 | 182152 | Dana Grossi | \$ | (225.00) | V |
| 1/9/2024 | 182244 | Aqua Pennsylvania | \$ | 605.48 | |
| 1/9/2024 | 182245 | Brian Barrett | \$ | 149.10 | |
| 1/9/2024 | 182246 | Carol A Fee | \$ | 35.00 | |
| 1/9/2024 | 182247 | Dallas Data Systems Inc | \$ | 9,401.00 | |
| 1/9/2024 | 182248 | DCTA | \$ | 10.00 | |
| 1/9/2024 | 182249 | Delaware Cty Police Chief's Association | \$ | 375.00 | |
| 1/9/2024 | 182250 | FP Finance Program | \$ | 125.00 | |
| 1/9/2024 | 182251 | J & J Landscaping Management, LLC | \$ | 1,930.00 | |
| 1/9/2024 | 182252 | James McCans | \$ | 691.97 | |
| 1/9/2024 | 182253 | Kevin Towell | \$ | 150.00 | |
| 1/9/2024 | 182254 | Mothers Compost LLC | \$ | 1,200.00 | |
| 1/9/2024 | 182255 | Nicole Baker | \$ | 100.00 | |
| 1/9/2024 | 182256 | Peco Energy | \$ | 66,718.23 | |
| 1/9/2024 | 182257 | Robert Sandy | \$ | 254.41 | |
| 1/9/2024 | 182258 | Toshiba America Business Solutions | \$ | 432.29 | |
| 1/9/2024 | 182259 | Toshiba Financial Service | \$ | 1,265.47 | |
| 1/9/2024 | 182260 | Zedd360 LLC | \$ | 45.60 | |
| 1/16/2024 | 182261 | APMM | \$ | 400.00 | |
| 1/16/2024 | 182262 | Aqua Pennsylvania | \$ | 46,730.91 | |
| 1/16/2024 | 182263 | Arthur J Gallagher Risk Mgmt Serv Inc | \$ | 31,139.60 | |
| 1/16/2024 | 182264 | Beth Ann Rush | \$ | 30.00 | |
| 1/16/2024 | 182265 | Comcast | \$ | 266.33 | |
| 1/16/2024 | 182266 | Comcast | \$ | 198.76 | |
| 1/16/2024 | 182267 | Comcast | \$ | 383.27 | |
| 1/16/2024 | 182268 | Comcast Business | \$ | 1,627.99 | |
| 1/16/2024 | 182269 | Dawn Griffin | \$ | 675.00 | |
| 1/16/2024 | 182270 | Deborah Tori | \$ | 56.62 | |
| 1/22/2024 | 182271 | Delaware County Fraternal Order of | \$ | - | V |
| 1/16/2024 | 182272 | DelCo Public Schools Healthcare Trst | \$ | 368,179.46 | |
| 1/16/2024 | 182273 | Diane M Hannold | \$ | 81.34 | |
| 1/16/2024 | 182274 | Eileen Mottola | \$ | 60.55 | |
| 1/16/2024 | 182275 | Flocco Inc | \$ | 8,731.00 | |
| 1/16/2024 | 182276 | Independence Blue Cross | \$ | 4,321.80 | |
| 1/16/2024 | 182277 | Independence Blue Cross | \$ | 5,868.27 | |

| | | | | |
|-----------|--------|--|----|------------|
| 1/16/2024 | 182278 | Independence Blue Cross | \$ | 1,658.22 |
| 1/16/2024 | 182279 | Independence Blue Cross | \$ | 5,868.27 |
| 1/16/2024 | 182280 | Independence Blue Cross | \$ | 4,561.90 |
| 1/16/2024 | 182281 | Independence Blue Cross | \$ | 1,658.22 |
| 1/16/2024 | 182282 | Jacob Low Hardware | \$ | 23.54 |
| 1/16/2024 | 182283 | Kate D'Arcy Edmiston | \$ | 150.00 |
| 1/16/2024 | 182284 | Lowe's | \$ | 1,411.58 |
| 1/16/2024 | 182285 | McLenaghan Wholesale Tires Inc | \$ | 140.00 |
| 1/16/2024 | 182286 | MLH Occupational & Travel Health | \$ | 212.00 |
| 1/16/2024 | 182287 | Oakmont Fire Company | \$ | 742.50 |
| 1/16/2024 | 182288 | Peco Energy | \$ | 1,204.82 |
| 1/16/2024 | 182289 | ReadyRefresh by Nestle Inc | \$ | 157.27 |
| 1/16/2024 | 182290 | Rick Turnbull | \$ | 113.01 |
| 1/16/2024 | 182291 | St Joseph's Preparatory School | \$ | 980.00 |
| 1/16/2024 | 182292 | T. Frank McCall's, Inc | \$ | 50.38 |
| 1/16/2024 | 182293 | Xtel Communications, Inc | \$ | 740.49 |
| 1/23/2024 | 182294 | Aqua Pennsylvania | \$ | 3,054.74 |
| 1/23/2024 | 182295 | Ascendance Truck LLC | \$ | 107,983.00 |
| 1/23/2024 | 182296 | Comcast | \$ | 131.90 |
| 1/23/2024 | 182297 | Comcast | \$ | 655.01 |
| 1/23/2024 | 182298 | Comcast | \$ | 153.66 |
| 1/23/2024 | 182299 | Comcast | \$ | 275.26 |
| 1/23/2024 | 182300 | Comcast | \$ | 156.85 |
| 1/23/2024 | 182301 | Federal Express Corp | \$ | 189.78 |
| 1/23/2024 | 182302 | Foley Inc | \$ | 9,302.00 |
| 1/23/2024 | 182303 | GranTurk Equipment Company Inc | \$ | 93,664.50 |
| 1/23/2024 | 182304 | Office Basics, Inc | \$ | 329.94 |
| 1/23/2024 | 182305 | Petty Cash - Haverford Township | \$ | 300.00 |
| 1/23/2024 | 182306 | ReadyRefresh by Nestle Inc | \$ | 300.91 |
| 1/23/2024 | 182307 | Strassheim Digital Imaging | \$ | 3,851.61 |
| 1/23/2024 | 182308 | Verizon | \$ | 61.18 |
| 1/23/2024 | 182309 | Vision Benefits of America | \$ | 605.88 |
| 1/26/2024 | 182310 | Postmaster | \$ | 10,595.81 |
| 1/30/2024 | 182311 | Aqua Pennsylvania | \$ | 2,161.89 |
| 1/30/2024 | 182312 | Arthur J Gallagher Risk Mgmt Serv Inc | \$ | 112,948.44 |
| 1/30/2024 | 182313 | Caroline D Scott | \$ | 263.00 |
| 1/30/2024 | 182314 | Comcast | \$ | 321.92 |
| 1/30/2024 | 182315 | Constellation NewEnergy Gas Division LLC | \$ | 4,501.24 |
| 1/30/2024 | 182316 | Dana Visanska | \$ | 225.00 |
| 1/30/2024 | 182317 | Eileen Mottola | \$ | 157.72 |
| 1/30/2024 | 182318 | Imperial Dade | \$ | 2,399.23 |
| 1/30/2024 | 182319 | Jake Ritter | \$ | 535.50 |
| 1/30/2024 | 182320 | North American Benefits Company | \$ | 4,702.90 |
| 1/30/2024 | 182321 | PA DEP | \$ | 100.00 |
| 1/30/2024 | 182322 | Philadelphia Zoo | \$ | 50.00 |
| 1/30/2024 | 182323 | Rachel Loev | \$ | 22.00 |
| 1/30/2024 | 182324 | ReadyRefresh by Nestle Inc | \$ | 1.99 |
| 1/30/2024 | 182325 | Staci Gillespie | \$ | 802.50 |
| 1/30/2024 | 182326 | Toshiba Financial Service | \$ | 1,265.47 |
| 1/30/2024 | 182327 | Tree Authority LLC | \$ | 1,257.00 |
| 1/30/2024 | 182328 | Vision Benefits of America | \$ | 112.00 |
| 2/6/2024 | 182329 | Andrew Payne | \$ | 45.00 |
| 2/6/2024 | 182330 | Arnold's Family Fun Center | \$ | 325.00 |

| | | | | |
|-----------|--------|--|----|-----------|
| 2/6/2024 | 182331 | AT & T Mobility | \$ | 5,188.46 |
| 2/6/2024 | 182332 | Brookline Baseball & Softball | \$ | 300.89 |
| 2/6/2024 | 182333 | City Wide Facility Solutions | \$ | 2,000.00 |
| 2/6/2024 | 182334 | Federal Express Corp | \$ | 52.15 |
| 2/6/2024 | 182335 | FP Finance Program | \$ | 125.00 |
| 2/6/2024 | 182336 | Llanerch Diner | \$ | 251.85 |
| 2/6/2024 | 182337 | North American Benefits Company | \$ | 3,065.12 |
| 2/6/2024 | 182338 | Patrick McNelis | \$ | 78.00 |
| 2/6/2024 | 182339 | Peco Energy | \$ | 69,262.10 |
| 2/6/2024 | 182340 | Pennsylvania State Assoc. of Boroughs | \$ | 30.00 |
| 2/6/2024 | 182341 | Petty Cash - Haverford Township | \$ | 67.28 |
| 2/6/2024 | 182342 | Shred Patrol LLC | \$ | 275.00 |
| 2/6/2024 | 182343 | Suzanne Guelli | \$ | 100.00 |
| 2/6/2024 | 182344 | Toshiba America Business Solutions | \$ | 323.06 |
| 2/6/2024 | 182345 | Urban Air - Delco | \$ | 1,547.97 |
| 2/12/2024 | 182346 | 21st Century Media-Philly Cluster | \$ | 2,540.75 |
| 2/12/2024 | 182347 | 911 Safety Equipment LLC | \$ | 150.00 |
| 2/12/2024 | 182348 | 95 Signs Inc | \$ | 850.00 |
| 2/12/2024 | 182349 | A Marinelli & Sons Inc | \$ | 2,746.00 |
| 2/12/2024 | 182350 | Aidan M Chivalette | \$ | 289.00 |
| 2/12/2024 | 182351 | Aidan McBrearty | \$ | 111.00 |
| 2/12/2024 | 182352 | A-Jon Construction Inc | \$ | 234.00 |
| 2/12/2024 | 182353 | All Traffic Solutions, Inc. | \$ | 5,500.00 |
| 2/12/2024 | 182354 | Allison Fineberg | \$ | 42.00 |
| 2/12/2024 | 182355 | American Biosoils & Compost LLC | \$ | 17,334.76 |
| 2/12/2024 | 182356 | American Swing Products Inc | \$ | 3,030.00 |
| 2/12/2024 | 182357 | Anthony Campese | \$ | 48.00 |
| 2/12/2024 | 182358 | Apex Elevator Inspection & Testing LLC | \$ | 60.00 |
| 2/12/2024 | 182359 | Ardmore Tire Inc | \$ | 5,200.16 |
| 2/12/2024 | 182360 | Arlene M. LaRosa, RPR | \$ | 397.00 |
| 2/12/2024 | 182361 | Ascendance Truck Pennsylvania LLC | \$ | 89,758.00 |
| 2/12/2024 | 182362 | Atlantic Tactical | \$ | 41.99 |
| 2/12/2024 | 182363 | Baltimore County Police Foundation Inc | \$ | 1,100.00 |
| 2/12/2024 | 182364 | Berrodin Parts Warehouse | \$ | 563.43 |
| 2/12/2024 | 182365 | Beth Ann Rush | \$ | 800.00 |
| 2/12/2024 | 182366 | BFI-King Of Prussia Recyclery | \$ | 36,005.27 |
| 2/12/2024 | 182367 | Bird Control Services Inc | \$ | 102.00 |
| 2/12/2024 | 182368 | Bound Tree Medical LLC | \$ | 176.93 |
| 2/12/2024 | 182369 | Brian James Bausman Jr | \$ | 357.00 |
| 2/12/2024 | 182370 | Bridgee Bees Floral Creations LLC | \$ | 70.00 |
| 2/12/2024 | 182371 | Bryce Pivovarnik | \$ | 289.00 |
| 2/12/2024 | 182372 | Bryn Mawr Racing Company | \$ | 460.00 |
| 2/12/2024 | 182373 | Cardone-Nuss Printing | \$ | 628.50 |
| 2/12/2024 | 182374 | Carol A Fee | \$ | 315.00 |
| 2/12/2024 | 182375 | Caroline D Scott | \$ | 145.00 |
| 2/12/2024 | 182376 | Cassandra Hawks | \$ | 216.00 |
| 2/12/2024 | 182377 | Charles E Watkins | \$ | 140.00 |
| 2/12/2024 | 182378 | Cherry Valley Tractor Sales | \$ | 445.57 |
| 2/12/2024 | 182379 | Church's Auto Parts | \$ | 426.76 |
| 2/12/2024 | 182380 | City Wide Facility Solutions | \$ | 1,881.10 |
| 2/12/2024 | 182381 | Clearnetwork Inc | \$ | 452.54 |
| 2/12/2024 | 182382 | Commonwealth of PA | \$ | 10.00 |
| 2/12/2024 | 182383 | CooperUniversity Physicians | \$ | 350.00 |

| | | | | |
|-----------|--------|---------------------------------------|----|------------|
| 2/12/2024 | 182384 | D M I Home Supply | \$ | 518.00 |
| 2/12/2024 | 182385 | Daktronics Inc | \$ | 250.00 |
| 2/12/2024 | 182386 | Daniel Gallagher | \$ | 322.50 |
| 2/12/2024 | 182387 | Daniel Henry Bell | \$ | 216.25 |
| 2/12/2024 | 182388 | Dean S Boornazian | \$ | 624.00 |
| 2/12/2024 | 182389 | Deborah Saldana | \$ | 120.00 |
| 2/12/2024 | 182390 | Delaware County Solid Waste Authority | \$ | 107,872.01 |
| 2/12/2024 | 182391 | Delaware Valley Turf | \$ | 2,183.10 |
| 2/12/2024 | 182392 | Del-Val International Trucks, Inc | \$ | 20,035.20 |
| 2/12/2024 | 182393 | Direct Paint & Collision Inc | \$ | 5,978.12 |
| 2/12/2024 | 182394 | Discover Haverford | \$ | 26,908.75 |
| 2/12/2024 | 182395 | Drugscan, Inc | \$ | 705.00 |
| 2/12/2024 | 182396 | Eagle Contracting & Landscaping, Inc | \$ | 9,240.00 |
| 2/12/2024 | 182397 | Eagle Wireless Communications LLC | \$ | 1,146.17 |
| 2/12/2024 | 182398 | Eastern Glove & Safety | \$ | 942.81 |
| 2/12/2024 | 182399 | Eastern Salt Company Inc | \$ | 5,119.08 |
| 2/12/2024 | 182400 | Elizabeth Luff | \$ | 200.00 |
| 2/12/2024 | 182401 | Elliott-Lewis | \$ | 2,700.00 |
| 2/12/2024 | 182402 | Emblem Enterprises, Inc | \$ | 2,685.01 |
| 2/12/2024 | 182403 | FBI-LEEDA | \$ | 100.00 |
| 2/12/2024 | 182404 | FencCo Inc | \$ | 9,573.00 |
| 2/12/2024 | 182405 | Fisher's Ace Hardware | \$ | 233.96 |
| 2/12/2024 | 182406 | Flag Products Inc | \$ | 349.00 |
| 2/12/2024 | 182407 | Flamm Walton Heimbach | \$ | 169.94 |
| 2/12/2024 | 182408 | Franklin Cleaning Equip & Supply Co | \$ | 293.86 |
| 2/12/2024 | 182409 | Gail Stickney | \$ | 157.26 |
| 2/12/2024 | 182410 | Galantino Supply Company Inc | \$ | 1,310.50 |
| 2/12/2024 | 182411 | General Code | \$ | 2,350.00 |
| 2/12/2024 | 182412 | Grace Baraldi | \$ | 45.00 |
| 2/12/2024 | 182413 | Grainger | \$ | 644.37 |
| 2/12/2024 | 182414 | GranTurk Equipment Company Inc | \$ | 5,799.55 |
| 2/12/2024 | 182415 | Guidemark Inc | \$ | 2,800.00 |
| 2/12/2024 | 182416 | H A DeHart & Son | \$ | 79,985.00 |
| 2/12/2024 | 182417 | Haverford Township Free Library | \$ | 111,692.34 |
| 2/12/2024 | 182418 | Havis Inc | \$ | 40,489.10 |
| 2/12/2024 | 182419 | Health Advocate Solutions Inc | \$ | 1,420.80 |
| 2/12/2024 | 182420 | Hill Buick GMC | \$ | 9,468.07 |
| 2/12/2024 | 182421 | Hill Manufacturing Company Inc | \$ | 122.27 |
| 2/12/2024 | 182422 | Hillyard /Delaware Valley Inc | \$ | 108.40 |
| 2/12/2024 | 182423 | Hockeytown 19083 LLC | \$ | 188.00 |
| 2/12/2024 | 182424 | Human Relations Media | \$ | 481.43 |
| 2/12/2024 | 182425 | IACP | \$ | 950.00 |
| 2/12/2024 | 182426 | Imperial Supplies LLC | \$ | 112.23 |
| 2/12/2024 | 182427 | J & C Ice Technologies Inc | \$ | 556.56 |
| 2/12/2024 | 182428 | Jacob Low Hardware | \$ | 69.98 |
| 2/12/2024 | 182429 | Jake Ritter | \$ | 548.25 |
| 2/12/2024 | 182430 | Jill Cosgrove | \$ | 324.00 |
| 2/12/2024 | 182431 | Joe's Automotive | \$ | 120.00 |
| 2/12/2024 | 182432 | JPS Equipment Co., Inc | \$ | 5,459.00 |
| 2/12/2024 | 182433 | K & S Towing & Recovery Inc | \$ | 678.00 |
| 2/12/2024 | 182434 | Kelly Industrial Supply | \$ | 2,278.02 |
| 2/12/2024 | 182435 | Keystone Municipal Services, Inc | \$ | 18,672.50 |
| 2/12/2024 | 182436 | Kieran Gillespie | \$ | 425.00 |

| | | | | |
|-----------|--------|---|----|-----------|
| 2/12/2024 | 182437 | Kilkenny Law, LLC | \$ | 9,653.75 |
| 2/12/2024 | 182438 | Lauren DiMartino | \$ | 105.00 |
| 2/12/2024 | 182439 | Linde Gas & Equipment Inc | \$ | 214.07 |
| 2/12/2024 | 182440 | Lisa A Drake | \$ | 175.00 |
| 2/12/2024 | 182441 | Little's | \$ | 489.80 |
| 2/12/2024 | 182442 | LogoWear House Inc | \$ | 2,230.75 |
| 2/12/2024 | 182443 | Maeve Hegarty | \$ | 48.00 |
| 2/12/2024 | 182444 | Main Line Mower-Tree Care Supplies | \$ | 756.31 |
| 2/12/2024 | 182445 | Manoa Cleaners, Inc | \$ | 946.35 |
| 2/12/2024 | 182446 | Mary Pat Hartline | \$ | 240.00 |
| 2/12/2024 | 182447 | Mason Paul | \$ | 285.00 |
| 2/12/2024 | 182448 | Maura Riscavage | \$ | 143.00 |
| 2/12/2024 | 182449 | Maxwell J Carfrey | \$ | 112.00 |
| 2/12/2024 | 182450 | McLenaghan Wholesale Tires Inc | \$ | 1,713.00 |
| 2/12/2024 | 182451 | McNichol, Byrne, & Matlawski, PC | \$ | 1,365.00 |
| 2/12/2024 | 182452 | MG Tree LLC | \$ | 700.00 |
| 2/12/2024 | 182453 | Mickey's Suburban Alignment Inc | \$ | 157.50 |
| 2/12/2024 | 182454 | MLH Occupational & Travel Health | \$ | 106.00 |
| 2/12/2024 | 182455 | MMJM Enterprises LLC | \$ | 1,189.60 |
| 2/12/2024 | 182456 | Mothers Compost LLC | \$ | 100.00 |
| 2/12/2024 | 182457 | National Tactical Officers Association | \$ | 35.00 |
| 2/12/2024 | 182458 | Nichols Plumbing & Heating, Inc | \$ | 200.00 |
| 2/12/2024 | 182459 | Noratek Solutions Inc | \$ | 3,307.50 |
| 2/12/2024 | 182460 | NRPA | \$ | 180.00 |
| 2/12/2024 | 182461 | Nuss Printing Inc | \$ | 450.50 |
| 2/12/2024 | 182462 | Office Basics, Inc | \$ | 4,104.88 |
| 2/12/2024 | 182463 | Oleg Altukhov | \$ | 324.00 |
| 2/12/2024 | 182464 | Orner's Garden Center | \$ | 140.00 |
| 2/12/2024 | 182465 | PA Chiefs of Police Association | \$ | 300.00 |
| 2/12/2024 | 182466 | Pacifico Marple Ford | \$ | 9,032.94 |
| 2/12/2024 | 182467 | Park's Best Car Wash Inc | \$ | 540.00 |
| 2/12/2024 | 182468 | Penn Power Group | \$ | 631.17 |
| 2/12/2024 | 182469 | Pennoni Associates, Inc | \$ | 5,015.22 |
| 2/12/2024 | 182470 | PeopleGuru Inc | \$ | 2,231.58 |
| 2/12/2024 | 182471 | Personal Protection Consultants inc | \$ | 1,794.00 |
| 2/12/2024 | 182472 | PetroChoice | \$ | 9,291.52 |
| 2/12/2024 | 182473 | Petroleum Traders Corp | \$ | 24,328.93 |
| 2/12/2024 | 182474 | PetSmart #1804 | \$ | 155.97 |
| 2/12/2024 | 182475 | Pi-Chi Yang | \$ | 140.00 |
| 2/12/2024 | 182476 | Pioneer Manufacturing Company | \$ | 735.90 |
| 2/12/2024 | 182477 | Police Chiefs Assoc. of Southeastern Pa | \$ | 75.00 |
| 2/12/2024 | 182478 | Port A Bowl Restroom Co Corp | \$ | 512.30 |
| 2/12/2024 | 182479 | PPS Print Solutions | \$ | 11,592.65 |
| 2/12/2024 | 182480 | Qualification Targets Inc | \$ | 450.84 |
| 2/12/2024 | 182481 | R.S. Sales & Service, Inc | \$ | 576.00 |
| 2/12/2024 | 182482 | Raffaele & Puppio, LLP | \$ | 2,951.00 |
| 2/12/2024 | 182483 | Riedell Shoes Inc | \$ | 3,712.35 |
| 2/12/2024 | 182484 | Robert Rinaldi | \$ | 56.00 |
| 2/12/2024 | 182485 | Sandi Kirschner | \$ | 175.00 |
| 2/12/2024 | 182486 | Sandy McGuire | \$ | 520.00 |
| 2/12/2024 | 182487 | School District of Haverford Township | \$ | 10,790.00 |
| 2/12/2024 | 182488 | School District of Haverford Township | \$ | 28,473.40 |
| 2/12/2024 | 182489 | Schwaab Inc | \$ | 222.99 |

| | | | | | |
|--------------------------|--------|---------------------------------------|----|--------------|---|
| 2/12/2024 | 182490 | Signal Service, Inc | \$ | 9,143.50 | |
| 2/12/2024 | 182491 | Sinclair Exterminating Inc | \$ | 690.00 | |
| 2/12/2024 | 182492 | Sir Speedy Printing Center #7099 | \$ | 2,428.00 | |
| 2/12/2024 | 182493 | Spectrum Letterbox | \$ | 7,790.00 | |
| 2/12/2024 | 182494 | Spike's Trophies Limited | \$ | 226.40 | |
| 2/12/2024 | 182495 | St Jude Shop Inc | \$ | 43.00 | |
| 2/12/2024 | 182496 | Staci Gillespie | \$ | 1,005.00 | |
| 2/12/2024 | 182497 | Super Fence Company | \$ | 1,250.00 | |
| 2/12/2024 | 182498 | Superior Alarm Systems Inc | \$ | 540.00 | |
| 2/12/2024 | 182499 | T. Frank McCall's, Inc | \$ | 3,554.57 | |
| 2/12/2024 | 182500 | Taddeo's Greenhouse Inc | \$ | 120.00 | |
| 2/12/2024 | 182501 | Tedder Industries LLC | \$ | 863.55 | |
| 2/12/2024 | 182502 | Thomson Reuters-West | \$ | 316.33 | |
| 2/12/2024 | 182503 | Tri County Canine, LLC | \$ | 150.00 | |
| 2/12/2024 | 182504 | Triple R Truck Parts | \$ | 2,326.63 | |
| 2/12/2024 | 182505 | Tri-State Financial Group LLC | \$ | 6,110.97 | |
| 2/12/2024 | 182506 | Tri-State/Ace Knife Grinding Corp | \$ | 262.00 | |
| 2/12/2024 | 182507 | TruckPro LLC Corp | \$ | 4,271.33 | |
| 2/12/2024 | 182508 | Turtle & Hughes, Inc | \$ | 2,672.25 | |
| 2/12/2024 | 182509 | Tustin Energy Solutions, LLC | \$ | 2,050.00 | |
| 2/12/2024 | 182510 | Tustin Mechanical Services LLC | \$ | 3,553.99 | |
| 2/12/2024 | 182511 | Tustin Water Solutions LLC | \$ | 381.00 | |
| 2/12/2024 | 182512 | ULINE, Inc | \$ | 105.37 | |
| 2/12/2024 | 182513 | VCA Wellington Animal Hospital | \$ | 357.30 | |
| 2/12/2024 | 182514 | Victory Gardens Inc | \$ | 800.00 | |
| 2/12/2024 | 182515 | W. B. Mason Co, Inc. | \$ | 140.00 | |
| 2/12/2024 | 182516 | William McKee | \$ | 238.00 | |
| 2/12/2024 | 182517 | Witmer Public Safety Group Inc | \$ | 4,228.11 | |
| 2/12/2024 | 182518 | YCG Inc | \$ | 3,341.75 | |
| 2/12/2024 | 182519 | Yearsley's Service, Ltd | \$ | 14.00 | |
| 2/12/2024 | 182520 | Zeager Bros., Inc | \$ | 9,066.26 | |
| Investment - PLGIT | | | | | |
| 1/9/2024 | 421 | Express Scripts Inc | \$ | 834.80 | M |
| 1/9/2024 | 422 | Express Scripts Inc | \$ | 38,596.44 | M |
| 1/12/2024 | 425 | Express Scripts Inc | \$ | 3.00 | M |
| 1/12/2024 | 426 | Express Scripts Inc | \$ | 52,689.69 | M |
| 1/30/2024 | 429 | Express Scripts Inc | \$ | 17.50 | M |
| 1/30/2024 | 430 | Express Scripts Inc | \$ | 34,967.45 | M |
| 1/9/2024 | 7092 | Express Scripts Inc | \$ | - | V |
| 1/9/2024 | 7093 | Express Scripts Inc | \$ | - | V |
| Total General Fund: | | | \$ | 2,022,441.19 | |
| Investment - Sewer PLGIT | | | | | |
| 1/9/2024 | 423 | Express Scripts Inc | \$ | 3,936.14 | M |
| 1/12/2024 | 427 | Express Scripts Inc | \$ | 65.47 | M |
| 1/30/2024 | 431 | Express Scripts Inc | \$ | 2.32 | M |
| Sewer Cash - Operating | | | | | |
| 1/16/2024 | 19581 | Arthur J Gallagher Risk Mgmt Serv Inc | \$ | 233.40 | |
| 1/16/2024 | 19582 | DelCo Public Schools Healthcare Trst | \$ | 9,519.55 | |
| 1/16/2024 | 19583 | Flocco Inc | \$ | 800.00 | |
| 1/23/2024 | 19584 | Vision Benefits of America | \$ | 195.70 | |
| 1/30/2024 | 19585 | Arthur J Gallagher Risk Mgmt Serv Inc | \$ | 6,149.76 | |
| 1/30/2024 | 19586 | North American Benefits Company | \$ | 64.80 | |

| | | | | |
|-------------------|-------|---|----|--------------|
| 2/6/2024 | 19587 | AT & T Mobility | \$ | 89.46 |
| 2/6/2024 | 19588 | North American Benefits Company | \$ | 113.55 |
| 2/12/2024 | 19589 | A Marinelli & Sons Inc | \$ | 822.00 |
| 2/12/2024 | 19590 | Bullen Companies Inc | \$ | 1,094.86 |
| 2/12/2024 | 19591 | Cawley Environmental Services Inc | \$ | 4,755.35 |
| 2/12/2024 | 19592 | Eagle Contracting & Landscaping, Inc | \$ | 35,600.00 |
| 2/12/2024 | 19593 | Galantino Supply Company Inc | \$ | 28.50 |
| 2/12/2024 | 19594 | H A DeHart & Son | \$ | 333.90 |
| 2/12/2024 | 19595 | Hilltop Distributors Co | \$ | 956.73 |
| 2/12/2024 | 19596 | Imperial Supplies LLC | \$ | 438.78 |
| 2/12/2024 | 19597 | Kilkenny Law, LLC | \$ | 503.75 |
| 2/12/2024 | 19598 | Linde Gas & Equipment Inc | \$ | 487.11 |
| 2/12/2024 | 19599 | Pennoni Associates, Inc | \$ | 1,262.50 |
| 2/12/2024 | 19600 | Pennsylvania One Call System Inc | \$ | 199.30 |
| 2/12/2024 | 19601 | Petroleum Traders Corp | \$ | 2,878.94 |
| 2/12/2024 | 19602 | School District of Haverford Township | \$ | 480.51 |
| 2/12/2024 | 19603 | Upper Darby Township Municipal Building | \$ | 1,920.87 |
| 2/12/2024 | 19604 | Upper Darby Township Municipal Building | \$ | 142,041.68 |
| Total Sewer Fund: | | | \$ | 214,974.93 |
| Grand Totals: | | | \$ | 3,048,768.23 |

Haverford Township
 Gross Payroll Dated January 18 2024
 (Imported from Paychex Payroll Service and formatted for ADA Accessibility)

| Department | Total Earnings | Total ER Taxes | Total Labor Cost |
|--------------------------|----------------|---------------------|------------------|
| 400 Administration | \$ 15,784.90 | \$ 1,168.29 | \$ 16,953.19 |
| 402 Finance | \$ 16,405.47 | \$ 1,221.61 | \$ 17,627.08 |
| 406 Human Resources | \$ 6,325.39 | \$ 483.90 | \$ 6,809.29 |
| 407 Info Technology | \$ 12,104.10 | \$ 893.70 | \$ 12,997.80 |
| 409 Facilities | \$ 18,572.65 | \$ 1,383.76 | \$ 19,956.41 |
| 410 Police | \$ 475,361.89 | \$ 8,618.68 | \$ 483,980.57 |
| 412 EMS Administration | \$ 9,636.02 | \$ 712.24 | \$ 10,348.26 |
| 413 Code Enforcement | \$ 24,702.11 | \$ 1,841.45 | \$ 26,543.56 |
| 416 Comm Development | \$ 3,044.84 | \$ 226.79 | \$ 3,271.63 |
| 427 Sanitation | \$ 80,089.12 | \$ 5,973.51 | \$ 86,062.63 |
| 429 Sewer Operations | \$ 18,074.21 | \$ 1,348.30 | \$ 19,422.51 |
| 430 PW Highways | \$ 108,907.70 | \$ 8,125.17 | \$ 117,032.87 |
| 450 Parks and Recreation | \$ 45,393.99 | \$ 3,402.35 | \$ 48,796.34 |
| 451 Ice Rink | \$ 20,855.44 | \$ 1,567.86 | \$ 22,423.30 |
| 454 Parks Maintenance | \$ 30,379.56 | \$ 2,265.84 | \$ 32,645.40 |
| Totals | \$ 885,637.39 | \$ 39,233.45 | \$ 924,870.84 |
| | | Less:Noncash Fringe | \$ (2,878.08) |
| | | | \$ 921,992.76 |
| | | Sewer Fund | \$ 19,422.51 |
| | | General Fund | \$ 902,570.25 |

Haverford Township
 Gross Payroll Dated February 1 2024
 (Imported from Paychex Payroll Service and formatted for ADA Accessibility)

| Department | Total Earnings | Total ER Taxes | Total Labor Cost |
|--------------------------|----------------|----------------|------------------|
| 400 Administration | \$ 15,257.56 | \$ 1,127.95 | \$ 16,385.51 |
| 402 Finance | \$ 14,873.97 | \$ 1,104.45 | \$ 15,978.42 |
| 406 Human Resources | \$ 6,325.39 | \$ 483.90 | \$ 6,809.29 |
| 407 Info Technology | \$ 12,054.42 | \$ 889.90 | \$ 12,944.32 |
| 409 Facilities | \$ 17,923.96 | \$ 1,334.17 | \$ 19,258.13 |
| 410 Police | \$ 349,597.53 | \$ 6,816.57 | \$ 356,414.10 |
| 412 EMS Administration | \$ 9,672.66 | \$ 715.04 | \$ 10,387.70 |
| 413 Code Enforcement | \$ 22,482.72 | \$ 1,671.67 | \$ 24,154.39 |
| 416 Comm Development | \$ 2,294.84 | \$ 169.41 | \$ 2,464.25 |
| 427 Sanitation | \$ 75,107.93 | \$ 5,592.42 | \$ 80,700.35 |
| 429 Sewer Operations | \$ 19,406.85 | \$ 1,450.25 | \$ 20,857.10 |
| 430 PW Highways | \$ 115,614.38 | \$ 8,633.53 | \$ 124,247.91 |
| 450 Parks and Recreation | \$ 40,181.75 | \$ 3,003.62 | \$ 43,185.37 |
| 451 Ice Rink | \$ 15,309.30 | \$ 1,143.59 | \$ 16,452.89 |
| 454 Parks Maintenance | \$ 33,968.23 | \$ 2,540.41 | \$ 36,508.64 |
| Totals | \$ 750,071.49 | \$ 36,676.88 | \$ 786,748.37 |
| | | Sewer Fund | \$ 20,857.10 |
| | | General Fund | \$ 765,891.27 |

Haverford Township
 Credit Card Summary
 (Formatted for ADA Accessibility)

Statement Ending Date: 1/27/2024
 Payment Posting Date: 2/5/2024

| Date | Vendor | Department | Description | GL Account | Amount |
|------------|------------------------|----------------|---|----------------|-------------|
| 1/2/2024 | PSU Cooperative Extens | Administration | Tree Tenders Training Series - A DeSanti | 01-400-2602.02 | \$ 40.00 |
| 1/2/2024 | PSU Cooperative Extens | Administration | Arborist Short Course Series - A DeSanti | 01-400-2602.02 | \$ 250.00 |
| 1/2/2024 | Isa | Administration | Arborists Certification Study Guide - A DeSanti | 01-400-2602.02 | \$ 133.22 |
| 1/3/2024 | Psats | Administration | PSATS Training - M Buchanan | 01-400-2602.02 | \$ 45.00 |
| 1/8/2024 | Omni Bedford Springs | Administration | Conference/Meeting lodging - D Burman | 01-400-2602.02 | \$ 224.06 |
| 1/8/2024 | Nudys Café | Administration | Working meeting with new Chief Of Narberth Ambulance | 01-400-2000.02 | \$ 38.75 |
| 1/13/2024 | EIG Constant Contact | Administration | Constant Contact Software | 01-400-2000.02 | \$ 137.75 |
| 12/28/2023 | Amazon | IT | (2) USB charger, laptop power supply adapter cord | 01-407-2002.02 | \$ 77.98 |
| 12/28/2023 | Philly Pretzel | Recreation | Rockin NYE pretzels | 01-450-9220.02 | \$ 90.00 |
| 12/28/2023 | Amazon | Recreation | Rockin NYE décor | 01-450-9220.02 | \$ 23.64 |
| 12/28/2023 | Amazon | Recreation | Rockin NYE candy | 01-450-9220.02 | \$ 52.41 |
| 12/28/2023 | Amazon | Public Works | Pre-cut write on wipe off magnetic strips | 01-430-2000.02 | \$ 11.95 |
| 12/29/2023 | National Construction | Recreation | Refund | 01-454-4301.02 | \$ (3.44) |
| 12/30/2023 | Bamboohr HRIS | HR | HRIS Monthly Subscription | 01-406-2005.02 | \$ 1,833.07 |
| 1/3/2024 | Amazon | Police | (3) Streamlight battery | 01-410-6109.02 | \$ 61.23 |
| 1/3/2024 | Amazon | Police | (2) Holster for iPhone 14 with belt clip | 01-410-2000.02 | \$ 35.70 |
| 1/3/2024 | Amazon | Police | (5) Tactical magazine pouch, (5) tactical radio pouch | 01-410-6000.02 | \$ 158.75 |
| 1/4/2024 | Amazon | Police | (2) Tactical drop leg gas mask hip platform | 01-410-6000.02 | \$ 71.90 |
| 1/4/2024 | Amazon | Administration | 1099 envelopes | 01-400-2002.02 | \$ 55.47 |
| 1/5/2024 | Amazon | Recreation | Steering wheel cover for Ford F-150 | 01-454-4301.02 | \$ 19.99 |
| 1/5/2024 | Amazon | Recreation | Pipe cleaners | 01-450-9220.02 | \$ 7.99 |
| 1/5/2024 | Amazon | Recreation | Pipe cleaners and elastic string for bracelets | 01-450-9220.02 | \$ 17.98 |
| 1/5/2024 | Amazon | Recreation | Foot straps for rower | 01-450-9220.02 | \$ 18.99 |
| 1/5/2024 | Amazon | Recreation | Watercolor refill bulk set of 50 | 01-450-9220.02 | \$ 34.19 |
| 1/5/2024 | Amazon | Recreation | Kids Night Out pizza | 01-450-9220.02 | \$ 350.00 |
| 1/6/2024 | Amazon | Police | 250 pack Poly coin bags, 72 pack 9V batteries | 01-410-6113.02 | \$ 344.99 |
| 1/6/2024 | Amazon | Recreation | Construction paper, pencil erasers, pony beads and watercolor paper | 01-450-9220.02 | \$ 54.06 |
| 1/7/2024 | Amazon | Recreation | 100 cup Percolate coffee maker | 01-450-9232.02 | \$ 109.99 |
| 1/7/2024 | Amazon | Administration | Label maker tape replacement | 01-400-2002.02 | \$ 10.49 |
| 1/8/2024 | Peloton | Police | Gym Expense (recurring) | 01-410-2000.02 | \$ 46.64 |
| 1/9/2024 | Amazon | Police | (2) 1,000 Wood coffee stirrers, (2) HP 64 ink cartridges | 01-410-2002.02 | \$ 109.76 |
| 1/9/2024 | Ndal.Org | Recreation | Environmental training - P Gilbert | 01-450-2602.02 | \$ 238.50 |
| 1/10/2024 | Amazon | Recreation | (5) Molle Double Pistol Mag pouch | 01-410-6000.02 | \$ 38.66 |
| 1/10/2024 | Amazon | Public Works | Neoprene boots | 01-430-2803.02 | \$ 164.99 |
| 1/10/2024 | Cummins Osm | Public Works | Cummins computer program | 01-411-5107.02 | \$ 770.00 |
| 1/10/2024 | Amazon | Police | (2) Storage clipboard | 01-410-6000.02 | \$ 47.48 |
| 1/10/2024 | Amazon | Police | Blackhawk duty belt | 01-410-2803.02 | \$ 62.16 |
| 1/10/2024 | Amazon | Police | Blackhawk duty belt | 01-410-2803.02 | \$ 59.98 |
| 1/10/2024 | The UPS Store | EAC/Admin | Shipping - TerraCycle | 01-427-2772.02 | \$ 13.72 |
| 1/10/2024 | Amazon | Recreation | (2) Aluminum Citation Holder | 01-410-6000.02 | \$ 48.98 |

| | | | | | |
|-----------|--------------------------|--------------|---|----------------|-------------|
| 1/10/2024 | Digicert | IT | 3 year certificate | 01-407-2005.02 | \$ 1,346.80 |
| 1/11/2024 | Amazon | Skatium | Commercial toilet seat | 01-451-5117.02 | \$ 51.38 |
| 1/11/2024 | Quiver Farm Project | Recreation | Chick Hatching | 01-450-9220.02 | \$ 375.00 |
| 1/11/2024 | BJS | Recreation | Little Explorers Snacks | 01-450-9220.02 | \$ 202.76 |
| 1/12/2024 | Amazon | Recreation | Little Explorers Snacks | 01-450-9220.02 | \$ 69.16 |
| 1/13/2024 | Intl Code Council Inc | Codes/ARPA | Inspector Training Program | 01-130.00 | \$ 83.74 |
| 1/15/2024 | Amazon | Recreation | Volleyball clinic | 01-450-9220.02 | \$ 125.44 |
| 1/16/2024 | Bagspot Pet Waste | Recreation | Dog waste bags | 01-454-4301.02 | \$ 398.65 |
| 1/16/2024 | Adobe Acropro Subs | HR | Subscription | 01-406-2000.02 | \$ 21.19 |
| 1/17/2024 | Amazon | Recreation | Little Explorers Snacks | 01-450-9220.02 | \$ 26.31 |
| 1/17/2024 | AWS Inc | Police | 40MM Bandoleer | 01-410-6103.02 | \$ 98.19 |
| 1/17/2024 | Amazon | HR | PA Labor law poster | 01-406-2000.02 | \$ 176.70 |
| 1/17/2024 | Plant Signs | EAC/Admin | Engraved plant id sign and stakes | 01-427-2772.02 | \$ 1,476.38 |
| 1/19/2024 | Home Depot | Police | Black rolling toolbox with keyed lock | 01-410-6141.02 | \$ 328.91 |
| 1/19/2024 | Amazon | Police | Windshield spray de-icer | 01-410-2003.02 | \$ 55.99 |
| 1/19/2024 | Amazon | Police | Snow brush with detachable ice scraper | 01-410-2003.02 | \$ 122.84 |
| 1/19/2024 | Amazon | Recreation | Measuring cup, aquarium cleaning brush and Folgers coffee | 01-450-9232.02 | \$ 75.35 |
| 1/21/2024 | Userway.org | IT | Accessibility scanning and monitoring | 01-407-2005.02 | \$ 99.00 |
| 1/22/2024 | Colonial Market | Fire | Awards dinner | 01-411-2603.02 | \$ 250.00 |
| 1/23/2024 | Amazon | Police | Uniform belt | 01-410-2803.02 | \$ 74.00 |
| 1/23/2024 | Onset Computer Corp | Recreation | Haverford Weather Station Annual HOBO Service Plan | 01-450-2000.02 | \$ 299.00 |
| 1/23/2024 | Amazon | Police | Lenovo Laptop | 01-450-2005.02 | \$ 594.99 |
| 1/23/2024 | Terminal Depot | Finance | Credit card machine paper rolls | 01-402-2002.02 | \$ 37.51 |
| 1/24/2024 | Boccellas | Public Works | Breakfast for snow storm | 01-430-2000.02 | \$ 190.00 |
| 1/24/2024 | Amazon | Recreation | Little Explorers Art Show | 01-450-9220.02 | \$ 94.29 |
| 1/24/2024 | Terminal Depot | Finance | Refund for credit card machine paper rolls | 01-402-2002.02 | \$ (37.51) |
| 1/24/2024 | Pennsylvania State Assoc | Comm Dev | Training - M Buchanan | 01-416-2602.02 | \$ 25.00 |
| 1/25/2024 | Intl Code Council Inc | Codes/ARPA | Inspector Apprentice Program | 01-130.00 | \$ 240.00 |
| 1/25/2024 | Amazon | Recreation | Apple USB-C Headphone jack adapter | 01-450-9220.02 | \$ 25.44 |

Total Credit Card Purchasing as of January 27, 2024

\$ 12,833.49

Township of Haverford -Finance Department

Memorandum

Date: February 05, 2024

To: David R. Burman, Township Manager

From: Aimee Cuthbertson, Director of Finance/Asst Township Manager

Re: Re-Appointment of Jennifer W. Brown, Esquire as Act 511 Special Counsel

For many years, the Township has utilized the professional services of Jennifer W. Brown, Esquire as special counsel for any matters related to the enforcement and administration of the Township's Act 511 taxes with primary emphasis on the business privilege, mercantile and local services tax.

As an expert in this specialty tax field unique to municipal entities, I am recommending Ms. Brown's reappointment as special counsel for Act 511 matters at a rate of \$250 per hour. The services of special counsel are on an "as needed" basis.

The recommendation has also been reviewed by John Walko in his role as Township Solicitor.

If you have any questions, please do not hesitate to contact me.

Township of Haverford - Ordinance Number P1-2024

An Ordinance of the Township of Haverford, County of Delaware, Commonwealth of Pennsylvania, amending and supplementing the General Laws of the Township of Haverford Chapter 95, Article III Recycling, Sections 95-23 and 95-25 by adding a definition of Community Event and requiring organizers to provide separate containers for and to collect recyclable materials.

Section 1. - § 95-23 Definitions.

Add: Community Event.

Any gathering that is open to the public including, without limitation, any parade, outdoor demonstration, meeting, dance, live entertainment, concert, rock group, stage show, burlesque, vaudeville, disc jockey or talent show, for any and all purposes.

Section 2. - § 95-25 Recyclables.

Add: G. Community Events.

(1) The organizers or sponsors of a community event shall establish a collection system that includes an appropriate number of recycling containers at easily accessible locations to accommodate the amount of recyclable materials generated. Community activity organizers and sponsors shall provide signage and/or labels on recycling containers to indicate what recyclable materials are to be source separated by event participants.

(2) Organizers or sponsors shall contact the township for the collection of recyclable materials, at a fee to be determined by the Township.

Section 3. Any ordinance or part of ordinance to the extent that it is inconsistent herewith is hereby repealed.

Section 4. Severability. The provision of this ordinance are severable and if any section, sentence, clause, part, or provision hereof shall be held illegal, invalid or unconstitutional by any court of competent jurisdiction, such decision of this shall not affect or impair the remaining sections, sentences, clauses, parts or provisions of this ordinance. It is hereby declared to be the Intent of the board that this ordinance would have been adopted if such illegal, invalid or unconstitutional section, sentence, clause, part or provision had not been included herein.

Section 5. Effective date. This ordinance shall become effective 10 days following final adoption by the board of commissioners and publication as required by law.

Adopted this 12th day of February, 2024.

Township of Haverford
By: C. Lawrence Holmes, Esq.
President Board of commissioners

Attested by: David R. Burman
Township Manager/Secretary

Township of Haverford - Ordinance Number P2-2024

An ordinance of the township of Haverford, County of Delaware, commonwealth of Pennsylvania, further amending and supplementing Ordinance No. 1960, adopted June 30, 1986, and known as "general laws of the Township of Haverford" chapter 175, vehicles and traffic.

Be it enacted and ordained by the Board of Commissioners of the Township of Haverford, County of Delaware, Commonwealth of Pennsylvania, and it is hereby enacted and ordained by the authority of the same:

Section 1. Section 175-94, Schedule XIX: Parking Time Limited

Establish:

On the west side of Allston Road from Brookline Boulevard to, but not including 1204 Allston Road, 15-minute parking from 8:00 a.m. to 4:00 p.m., Monday through Friday

Section 2. That Section 175-91, Schedule XVI: Parking of All Vehicles Prohibited at All Times

Rescind:

East side of Allston Road from Brookline Boulevard to Sagamore

West side of Allston Road from Brookline Boulevard to a point 35 feet south thereof

Section 3. That Section 175-95, Schedule XX: Special Purpose Parking Zones:

Rescind:

On the West side of Allston Road, approximately 75 feet south of its intersection with Brookline Boulevard

Section 4. Upon effective date of this ordinance, the Highway Department shall install appropriate signs in the designated section or zones giving notice of the regulations aforesaid.

Section 5. Any ordinance or part of an ordinance to the extent that it is inconsistent herewith is hereby repealed.

Adopted this 12th day of February, 2024.

Township of Haverford

By: C. Lawrence Holmes, Esq.
President

Attest: David R. Burman
Township Manager/Secretary

Township of Haverford - Ordinance Number P3-2024

An Ordinance of the Township of Haverford, County of Delaware, Commonwealth of Pennsylvania, further amending and supplementing Ordinance 1960, adopted June 30, 1980, and known as the "General Laws of the Township of Haverford" authorizing the lease of certain township grounds.

Now, therefore, it is hereby ordained and enacted that:

Section I: Pursuant to Section 707, paragraph A, of the Home Rule Charter, the Township hereby authorizes a renewal lease agreement with Shef & Sons, LLC dba Hav-A-Burger, Essington, PA for a portion of certain property located at 1018 Darby Road (the Skatium), Havertown, PA subject to review by the Township Solicitor and further subject to the approval of the Township Manager of the final document.

Section II: All Township elected and appointed officials are authorized to take all action necessary to ensure the implementation and effect the purpose hereof.

Section III: Any and all Ordinances and/or Resolutions, or parts thereof, conflicting herewith are repealed insofar as the matters herein are affected.

Section IV: This is effective ten (10) days following final adoption by the Board of Commissioners and publication as required by law, and shall remain in effect hereafter until revised, amended, or revoked by action of the Board of Commissioners of the Township of Haverford.

Adopted by the Township Board of Commissioners this (day) day of (month) , 2024.

Township of Haverford

By:

C. Lawrence Holmes, Esq.
President, Board of Commissioners

Attest:

David R. Burman,
Township Manager/Secretary

Township of Haverford - Finance Department

Memorandum

Date: February 05, 2024

To: David R. Burman, Township Manager

From: Aimee Cuthbertson, Director of Finance/Asst Township Manager

Re: Renewal of Skatium Café Lease

Staff has been in lease renewal discussions with the current tenant as the existing lease expired January 31, 2024. A two-year renewal term is proposed.

The current rent is \$1,300 per month with \$50 per party hosted in the upstairs party room. Renewal terms, which have been agreed to in principle, will be an increase to \$1,360 in year 1 of the renewal and to \$1,425 in year 2. The \$50 party fee will remain unchanged.

We added language including a required cleaning of the exhaust hood system every six (6) months, at the expense of the tenant. Additionally, the Township committed to the installation of a concrete pad for trash storage on the café entrance side behind the existing fenced trash area. This is planned for the Spring of 2024 and will be completed by Township staff.

If you have any questions, please do not hesitate to contact me.

Township of Haverford - Ordinance Number P4-2024

An Ordinance of the Township of Haverford, County of Delaware, Commonwealth of Pennsylvania, further amending and supplementing ordinance no. 1960, adopted June 30, 1986, and known as "General Laws of the Township of Haverford" Chapter 175, Vehicles and Traffic.

Be it enacted and ordained by the Board of Commissioners of the Township of Haverford, County of Delaware, Commonwealth of Pennsylvania, and it is hereby enacted and ordained by the authority of the same:

Section 1. That Section 175-96, Article XX, Special Purpose Parking Zones:
Establish in front of 2447 Wynnefield Drive

Section 2. That Section 175-91 Schedule XVI: Parking of All Vehicles Prohibited at All Times:
No Parking Here to Corner
the unit block of Colfax Road, north side, from the corner of Darby Road to a point 60 feet west.

Section 3. That Section 175-99, Schedule XXIV, Sticker Parking Only
Rescind Permit Parking Only on Mifflin Avenue

Section 4. Upon effective date of this ordinance, the Highway Department shall install appropriate signs in the designated section or zones giving notice of the regulations aforesaid.

Section 5. Any ordinance or part of an ordinance to the extent that it is inconsistent herewith is hereby repealed.

Adopted this day of , 2024.

Township of Haverford

C. Lawrence Holmes, Esq.
President

Attest: David R. Burman
Township Manager/Secretary

Township of Haverford - Ordinance Number P4-2024

An Ordinance of the Township of Haverford, County of Delaware, Commonwealth of Pennsylvania, further amending and supplementing ordinance no. 1960, adopted June 30, 1986, and known as "General Laws of the Township of Haverford" Chapter 175, Vehicles and Traffic.

Be it enacted and ordained by the Board of Commissioners of the Township of Haverford, County of Delaware, Commonwealth of Pennsylvania, and it is hereby enacted and ordained by the authority of the same:

Section 1. That Section 175-96, Article XX, Special Purpose Parking Zones:
Establish in front of 2447 Wynnefield Drive

Section 2. That Section 175-91 Schedule XVI: Parking of All Vehicles Prohibited at All Times:
No Parking Here to Corner
the unit block of Colfax Road, north side, from the corner of Darby Road to a point 60 feet west.

Section 3. That Section 175-99, Schedule XXIV, Sticker Parking Only
Rescind Permit Parking Only on Mifflin Avenue

Section 4. Upon effective date of this ordinance, the Highway Department shall install appropriate signs in the designated section or zones giving notice of the regulations aforesaid.

Section 5. Any ordinance or part of an ordinance to the extent that it is inconsistent herewith is hereby repealed.

Adopted this day of , 2024.

Township of Haverford

C. Lawrence Holmes, Esq.
President

Attest: David R. Burman
Township Manager/Secretary

Resolution No. 2360-2024

Whereas, the Preliminary / Final Subdivision / Land Development Plan for Carmanico Homes, LLC, 14 Claremont Blvd., Haverford, PA, Delaware County, known as D.C. Folio Nos. 22-00-00355-00 has been submitted to subdivide an existing 30,625 square foot lot into three building lots resulting in the following area: Lot 1 to contain 10,210 square feet, Lot 2 to contain 10,208 square feet and Lot 3 to contain 10, 208 square feet. Each lot is proposed with a single-family dwelling of 1,785 square feet with individual on-site stormwater facilities.

The properties are zoned R-5 Low-to-Medium Density Residential District, and are located in the 1st Ward. The aforesaid plans were prepared by G.D Houtman & Son, Inc., Media, PA, dated November 30, 2023; and

Whereas, the Planning Commission of Haverford Township at the public meeting of Thursday, January 11, 2024, did vote to recommend approval of the plans subject to the comments contained within the January 4, 2024 review letter prepared by Pennoni Associates and that the open space requirement be addressed to the Board of Commissioners satisfaction; and

Whereas, said plans have been submitted before the Board of Commissioners of the Township of Haverford for consideration in accordance with the Pennsylvania Municipalities Planning Code, Act 247, as amended, and pursuant to the Haverford Township Subdivision and Land Development Regulations, Ordinance 1960, Chapter 160, Sections 4. A and B,

Now, therefore, be it Resolved, by the Board of Commissioners of the Township of Haverford, County of Delaware, Commonwealth of Pennsylvania, that the recommendations and findings of the Planning Commission are hereby adopted and the Preliminary / Final / Land Development Plan for Carmanico Homes, LLC, 14 Claremont Blvd., Haverford Township, Delaware County, dated November 30, 2023, is approved subject to compliance with the recommendations described hereinabove.

Resolved this 12th day of February, 2024.

Township of Haverford

By: C. Lawrence Holmes, Esq. President
President, Board of Commissioners

Attest: David R. Burman,
Township Manager/Secretary

The Applicant hereby acknowledges that any revision to the approved SWM site plan must be approved by the Municipality, and that a revised erosion and sediment control plan must be submitted to the Conservation District for a determination of adequacy.

Present Owner _____
Date _____

CORPORATE ACKNOWLEDGMENT FOR PLAN

COMMONWEALTH OF PENNSYLVANIA :
COUNTY OF DELAWARE :

On this _____ day of _____, 2023, before me the undersigned, personally appeared Daniel Caramanico, who being duly sworn according to law, acknowledged himself/herself to be President of Caramanico Homes, LLC and that he, as such officer duly authorized to do so, deposes and says that Caramanico Homes, LLC is the owner/Equitable Owner of the property shown on this Plan, that this Plan was made at the direction of the Corporation and the Corporation acknowledges the same to be its act and Plan and desires the same to be recorded as such according to law.

Witness my hand and seal the day above written.

Corporate Name: Caramanico Homes, LLC
By: Daniel Caramanico
Title: President
Notary Public: _____
My Commission Expires: _____

State of Pennsylvania, County of Delaware

On this _____ day of _____, 2023, before me, the undersigned officer, personally appeared _____, who being duly sworn according to law, deposed and says that he is the the owner (or equitable owner) of the property shown on this plan, that the subdivision plan therof was made at his direction and that he acknowledges the same to be his act and plan and desires the same to be recorded as such according to law.
Witness my hand and seal the day and date above written.

(signature of individual)
(Notary public or other officer)
(My commission expires)

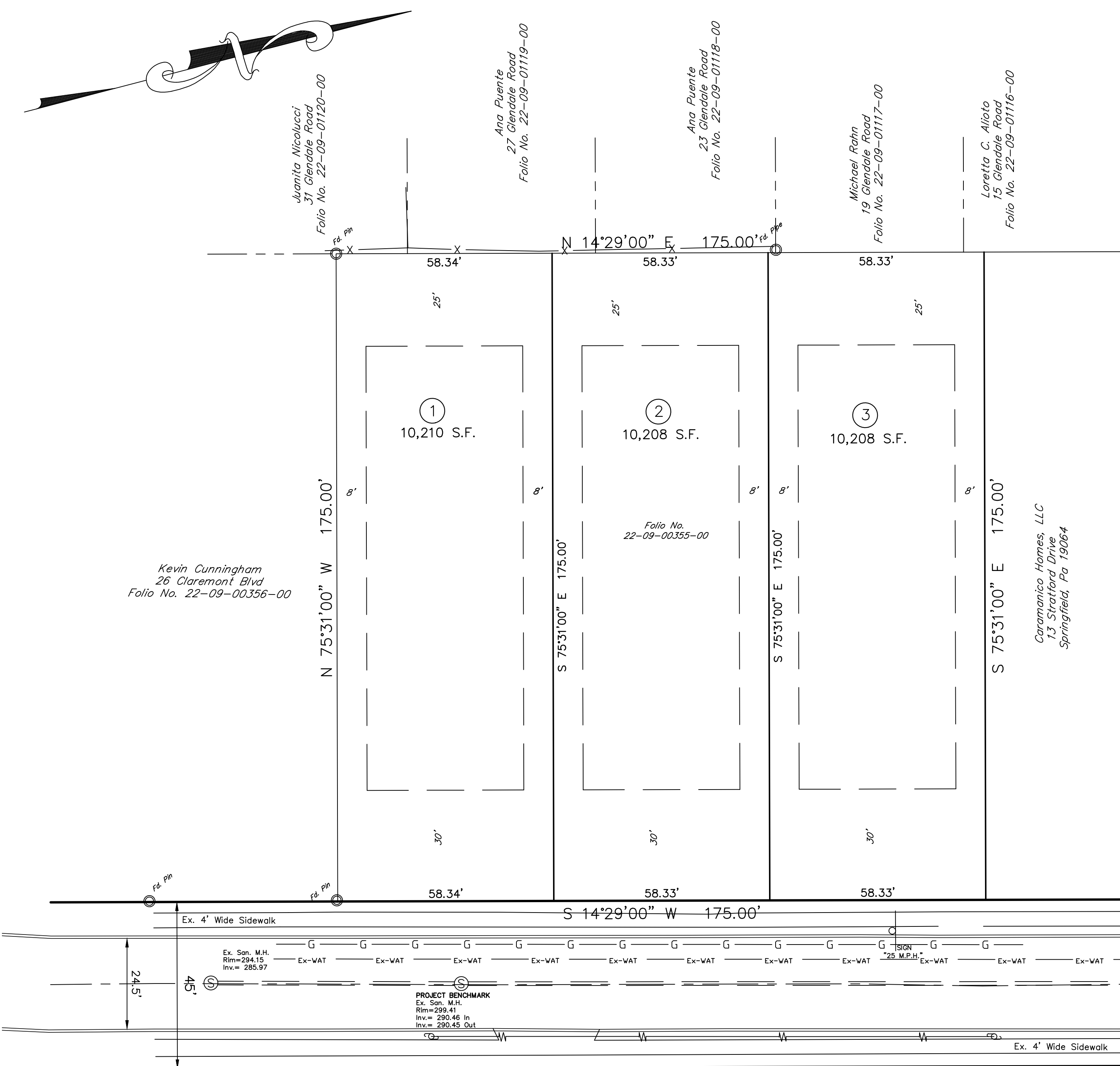

Kevin Cunningham
26 Claremont Blvd
Folio No. 22-09-00356-00

Caramanico Homes, LLC
13 Stratford Drive
Springfield, Pa 19064

CLAREMONT BOULEVARD

DESIGN ENGINEERS CERTIFICATIONS:

- I hereby certify that the Stormwater Management Site Plan meets all design standards and criteria of the Haverford Township Stormwater Management Ordinance.
- The proposed grading activities shall not significantly increase stormwater runoff to, and/or otherwise adversely impact, downstream properties except as may be part of an approved Stormwater Management Plan (as defined by Haverford Township Code).
- The accuracy of this plan and details are in accordance with Act 367, known as the Professional Engineers Registration Law (P.L. 913, No. 367.63 P.S. 151), as amended.

I, Gustave N. Houtmann, P.E., on this date hereby certify, to the best of my knowledge and belief, that the aforementioned statements and certifications are true and accurate.

(Signature & Seal) _____ Date _____

The information shown on this plan is the result of a professional service rendered by G.D. Houtman & Son, Inc. Reproduction of this plan without approval of G.D. Houtman & Son, Inc. is not permitted. The reproduction of a copy of this plan for the purpose of creating additional copies or making a copy of this plan shall, in no circumstance, be approved. Certification for the work contained herein is limited to the entity for whom the work was performed as of the date shown on the plans.
Note: All locations of existing utilities shown on the plan have been developed from existing utility records and / or above ground examination of the site. Completeness or accuracy of locations and depth of underground utilities or structures cannot be guaranteed. Contractor must verify location and depth of all underground utilities and facilities before start of work, as per PA Act 181 as per the latest amendment of PA Act 287 of 1974, Effective Mar. 28, 2007.

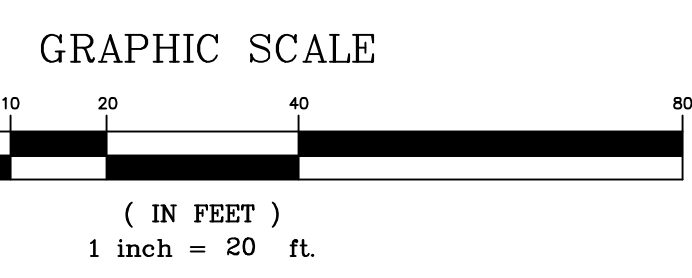

POST CONSTRUCTION STORMWATER MANAGEMENT NOTES:

- Post development stormwater management facilities at the property consist of the following:
 - Underground stormwater infiltration Bed.
 - Maintenance responsibilities for all the Stormwater facilities on the site, including the underground Stormwater Detention/Retention Basins and Underground Infiltration Bed, shall be that of the individual lot owner(s) on which the BMP's are located.
 - Maintenance program:
 - Infiltration beds:**
Infiltration beds shall be inspected on a Quarterly Basis
 - Debris Trap:**
A sump area has been provided within each inlet servicing the proposed seepage bed. The sump area of the inlet is the area between the bottom of the lowermost pipe in the inlet and the bottom of the Inlet Box. Inspect debris trap at the noted frequencies. Remove debris and sediment from the sump areas when it has reached a depth of eight (8) inches. Dispose sediment and debris in accordance with local ordinances.
 - Stone Infiltration Area:**
Inspect stone infiltration area at the noted frequencies. Ensure that ponded water at infiltration bed is percolating properly. Monitor water level in seepage bed area by inspecting water level in debris traps. Water at infiltration bed location as viewed from debris trap should not stay ponded for more than 3 days. Stone and sediment shall be removed from clogged beds and replaced as necessary. Install new filter fabric at repaired areas.

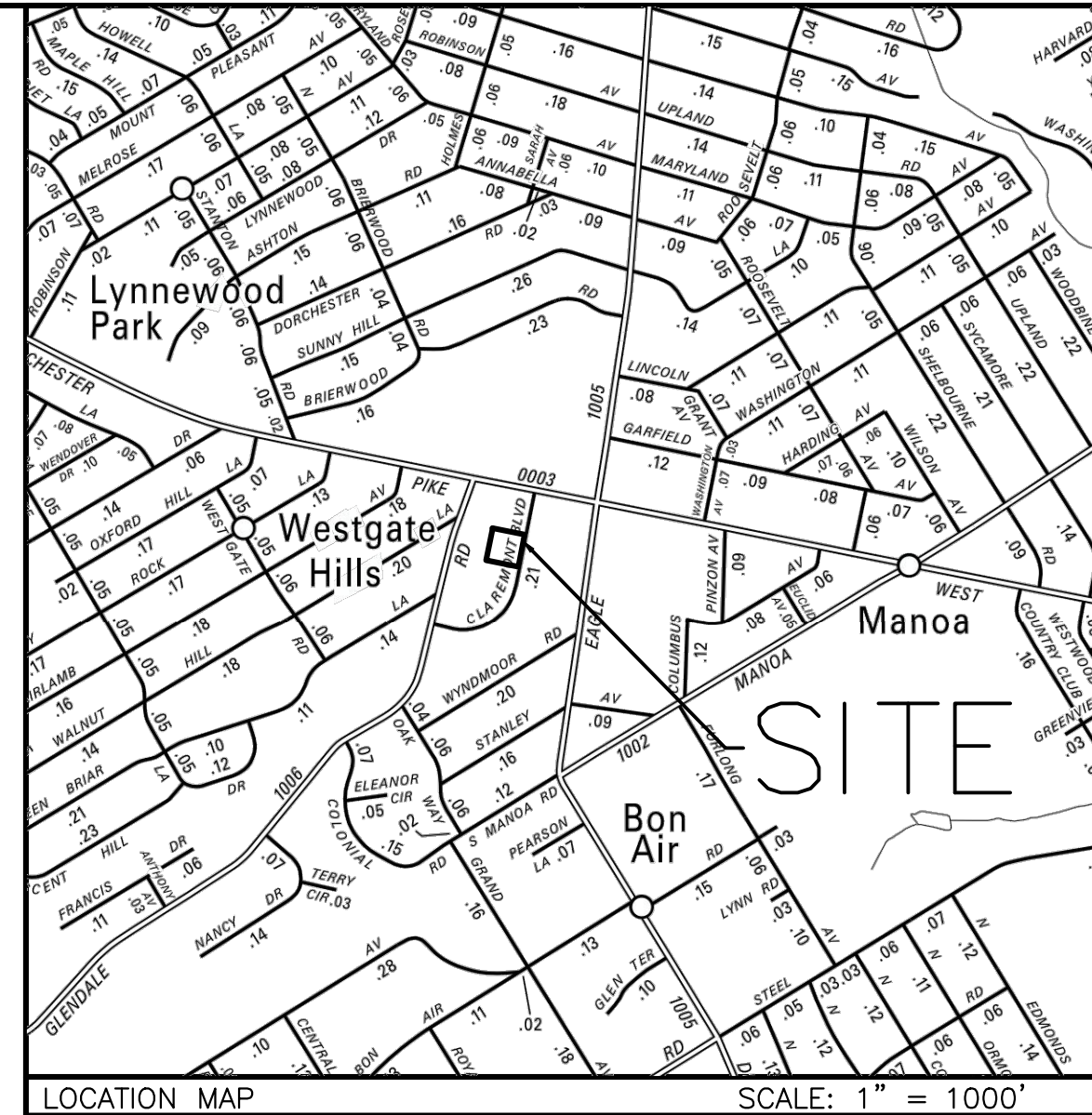

GENERAL NOTES:

Purpose: Applicant is proposing the subdivision of parcel 22-00-00355-00 into 3 Lots. The created lots will be developed with single family custom homes.

- Lot Area 30,625 S.F. (0.703 Acres)
- Zoned R-5

| Minimum Lot Size | Required | Proposed |
|-------------------------------|--------------------|----------------------|
| Minimum Lot Size | 5,500 Sq.Ft. | 10,208 s.f. Min |
| Minimum Lot Width at street | 38' | 58.33' |
| Minimum Lot Width at building | 50' | 58.33' |
| Minimum Front Yard | 30' | 31' |
| Minimum Side Yard | 8' | 8.42' |
| Minimum Side Yard Aggr. | 16' | 16.84' |
| Minimum Rear Yard | 25' | 101' |
| Maximum Building Coverage | 30% | 17.5% (1,785 s.f.) |
| Maximum Impervious Coverage | 45% | 23.0% (2,350 s.f.) |
| Maximum Height | 35' or 3.5 Stories | < 35' or 3.5 Stories |
- Site contains no Steep or Very Steep Slopes.
- Lots serviced by public water service and sewage disposal.
- Contours from field survey performed using Global Positioning System (GPS) Equipment. Elevation Per North American Vertical Datum of 1988. Project Benchmark - Rim of sanitary manhole located in Claremont Boulevard. Rim = 299.41
- Soils information from Soil Survey- Chester and Delaware Counties, Pennsylvania, Series 1959, No. 19, Issued May 1963. The Soil Types are as follows:
Me - Made land schist & gneiss materials
Mc - Made land silt & clay materials
- Owner/Applicant: Caramanico Homes, LLC
13 Stratford Drive
Springfield, PA 19064
- There is no 100-Year Flood Plain on this site as shown on the Flood Insurance rate Map (FIRM), Delaware County, Pa, Panel 102 of 250, Map Number 42045C0102F - Map revised November 18, 2009
- Reference Plan: Plan of Lots of "Claremont Hills", dated April 7th, 1925 prepared by Franklin & Company.
- This plan represents lots 199 through 204, Block I as shown on the reference plan.
- Addresses for the proposed lots are to be provided by the Township and or local post office.
- All standard curb and sidewalk along the property frontages shall be replaced at the discretion of the Township Engineer.
- Work is scheduled to begin June '24 and completed in June '25.

WAIVER REQUEST:

160-3E - The applicant is requesting a waiver from Preliminary Plan submittal and to submit plans as Final.

Recorder of Deeds _____ Delaware County Planning Commission _____

| | | | | |
|---------------------------|----------|-------------------|---|---|
| DATE | REVISION | SCALE 1" = 20' | RECORD PLAN OF PROPERTY FOR CARAMANICO HOMES, LLC HAVERFORD TOWNSHIP DELAWARE COUNTY, PA G.D. HOUTMAN & SON, INC. CIVIL ENGINEERS-LAND SURVEYORS 139 EAST BALTIMORE PIKE MEDIA, PA 19063 (610)585-4383 | Sheet 1 of 6 PROJECT Caramanico WORK SHEET 39258 FILE 39258 |
| DATE November 30, 2023 | | | | G.D. HOUTMAN & SON, INC. ENGINEER 00026-E PENNSYLVANIA |

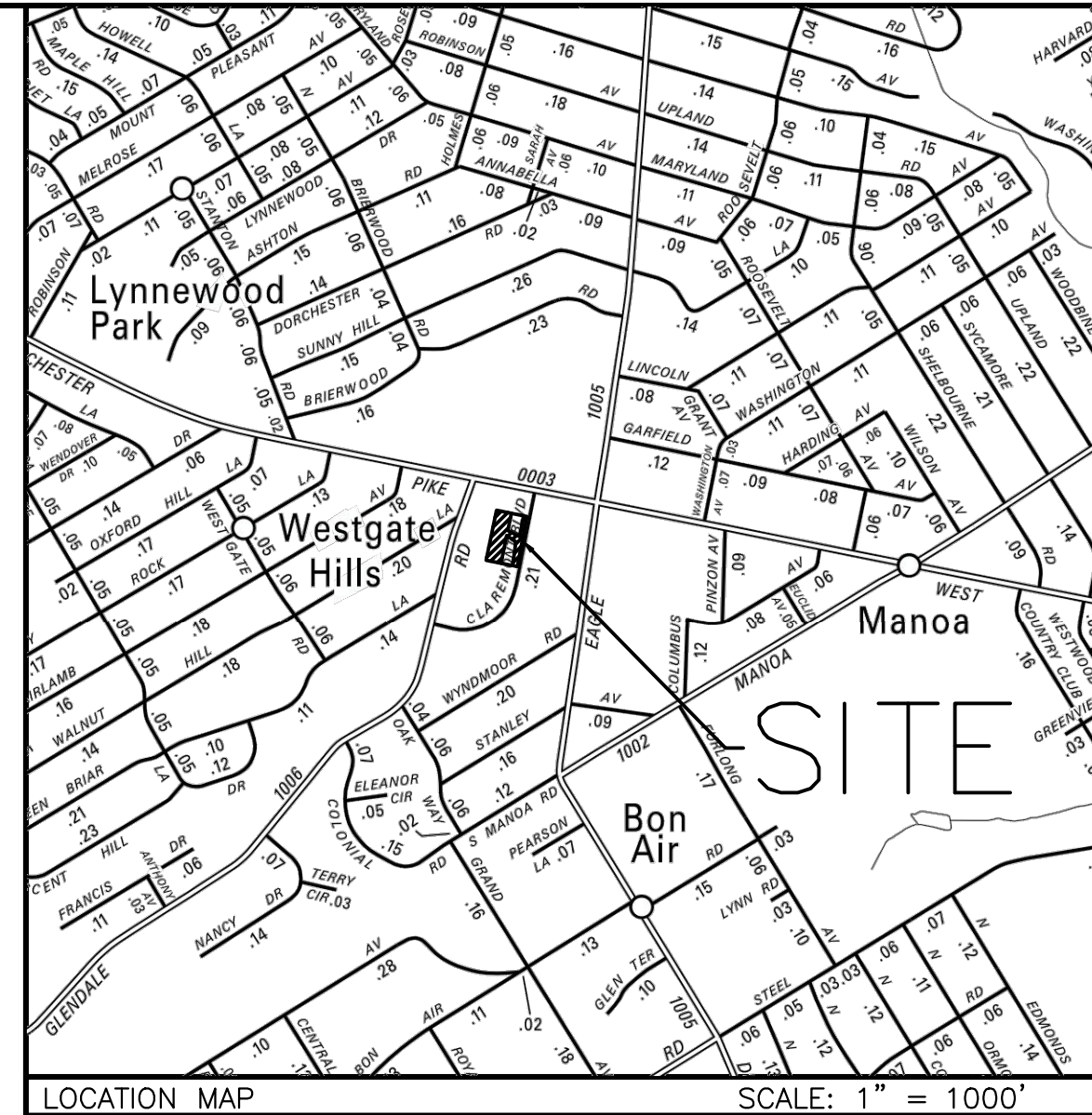
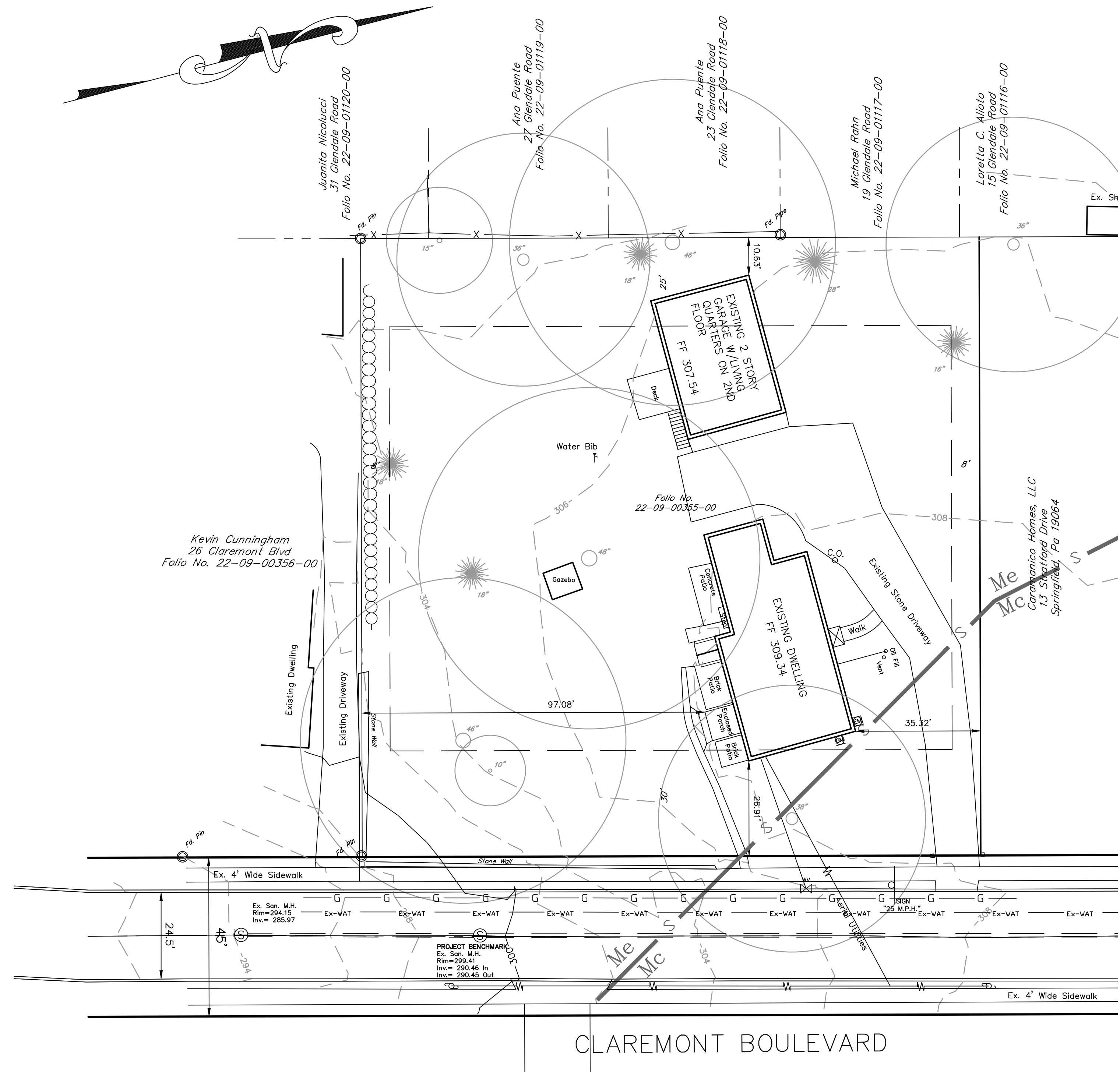

- GENERAL NOTES:
- Lot Area 30,625 S.F. (0.703 Acres)
 - Zoned R-5
 - Minimum Lot Size - 5,500 Sq.Ft.
 - Minimum Lot Width
 - at street - 38'
 - at building - 50'
 - Minimum Front Yard - 30'
 - Minimum Side Yard - 8'
 - Minimum Side Yard Aggr. - 16'
 - Minimum Rear Yard - 25'
 - Maximum Building Coverage - 30%
 - Maximum Impervious Coverage - 45%
 - Maximum Height - 35' or 3.5 Stories
 - Site contains no Steep or Very Steep Slopes.
 - Lots serviced by public water & public sewage.
 - Contours from field survey performed using Global Positioning System (GPS) Equipment. Elevation Per North American Vertical Datum of 1988. Project Benchmark - Rim of sanitary manhole located in Claremont Boulevard. Rim = 299.41
 - Soils information from Soil Survey- Chester and Delaware Counties, Pennsylvania, Series 1959, No. 19, Issued May 1963. The Soil Types are as follows:
 - Me - Made land schist & gneiss materials
 - Mc - Made land silt & clay materials
 - Owner/Applicant: Caramanico Homes, LLC
13 Stratford Drive
Springfield, PA 19064
 - There is no 100-Year Flood Plain on this site as shown on the Flood Insurance rate Map (FIRM), Delaware County, Pa, Panel 102 of 250, Map Number 42045C0102F - Map revised November 18, 2009

- LEGEND
- EXISTING UTILITY POLE
 - EXISTING WATER VALVE
 - EXISTING DECIDUOUS TREE
 - EXISTING EVERGREEN TREE
 - DENOTES EXISTING TREE TO BE REMOVED
 - EXISTING 2' CONTOUR
 - EXISTING 10' CONTOUR
 - EXISTING INLET
 - EXISTING SANITARY MANHOLE
 - EXISTING SANITARY SEWER
 - EXISTING WATER MAIN
 - EXISTING WATER SERVICE
 - EXISTING GAS LINE
 - EXISTING FENCES
 - PERCOLATION TEST LOCATION

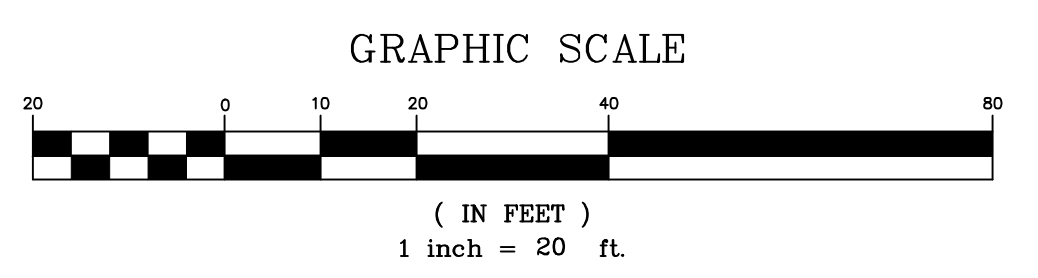

The information shown on this plan is the result of a professional service rendered by G.D. Houtman & Son, Inc. Reproduction of this plan without approval of G.D. Houtman & Son, Inc. is not permitted. The reproduction of a copy of this plan for the purpose of creating additional copies or making a plan shall, in no circumstance, be approved. Certification for the work contained herein is limited to the entity for whom the work was performed as of the date shown on the plans.

Note: All locations of existing utilities shown on the plan have been developed from existing utility records and / or above ground examination of the site. Completeness or accuracy of locations and depth of underground utilities or structures cannot be guaranteed. Contractor must verify location and depth of all underground utilities and facilities before start of work, as per PA Act 181 as per the latest amendment of PA Act 287 of 1974, Effective Mar. 28, 2007.

G. D. Houtman & Son, Inc. reserves its common law copyright and all other proprietary rights in these plans. All drawings, specifications and copies thereof are to remain property of G. D. Houtman & Son, Inc. They are to be used only in respect to this project. They are not to be assigned or represented to be suitable for reuse by owner or others on extensions of project or any other project. They are not to be assigned to any third party without first obtaining written permission by G.D. Houtman & Son, Inc. Any re-use without written permission for the specific purpose intended will be at the third party's sole risk and without liability or legal exposure to G. D. Houtman & Son, Inc. The third party shall further indemnify and hold harmless G. D. Houtman & Son, Inc. from all claims, damages, losses and expenses arising thereto or resulting therefrom.

These plans were prepared to obtain Subdivision/Land Development approval from the governing Municipality and to obtain certain permits from state and federal agencies. If a surveyor or engineer other than G. D. Houtman & Son, Inc. is contacted to perform construction stake-out services, sold surveyor or engineer shall assume the responsibility for verifying dimensions, elevations, presence of underground utilities, utility interference, building size, etc. for coordinating information shown on lay-out plans, grading plans, utility plans, profiles, and details and for coordinating these plans with plans prepared by others such as utility companies, architectural building plans, landscape plans, lighting plans and etc.

| DATE | REVISION | SCALE | EXISTING CONDITIONS PLAN OF PROPERTY FOR CARAMANICO HOMES, LLC HAVERFORD TOWNSHIP DELAWARE COUNTY, PA |
|------|----------|---------------------------------------|--|
| | | 1" = 20' DATE November 30, 2023 | |
| | | | G.D. HOUTMAN & SON, INC. CIVIL ENGINEERS-LAND SURVEYORS LAND PLANNERS 139 EAST BALTIMORE PIKE MEDIA, PA 19063 (610)565-6363 |
| | | | Sheet 2 of 6 PROJECT Caramanico WORK SHEET FILE 39258 39258 |

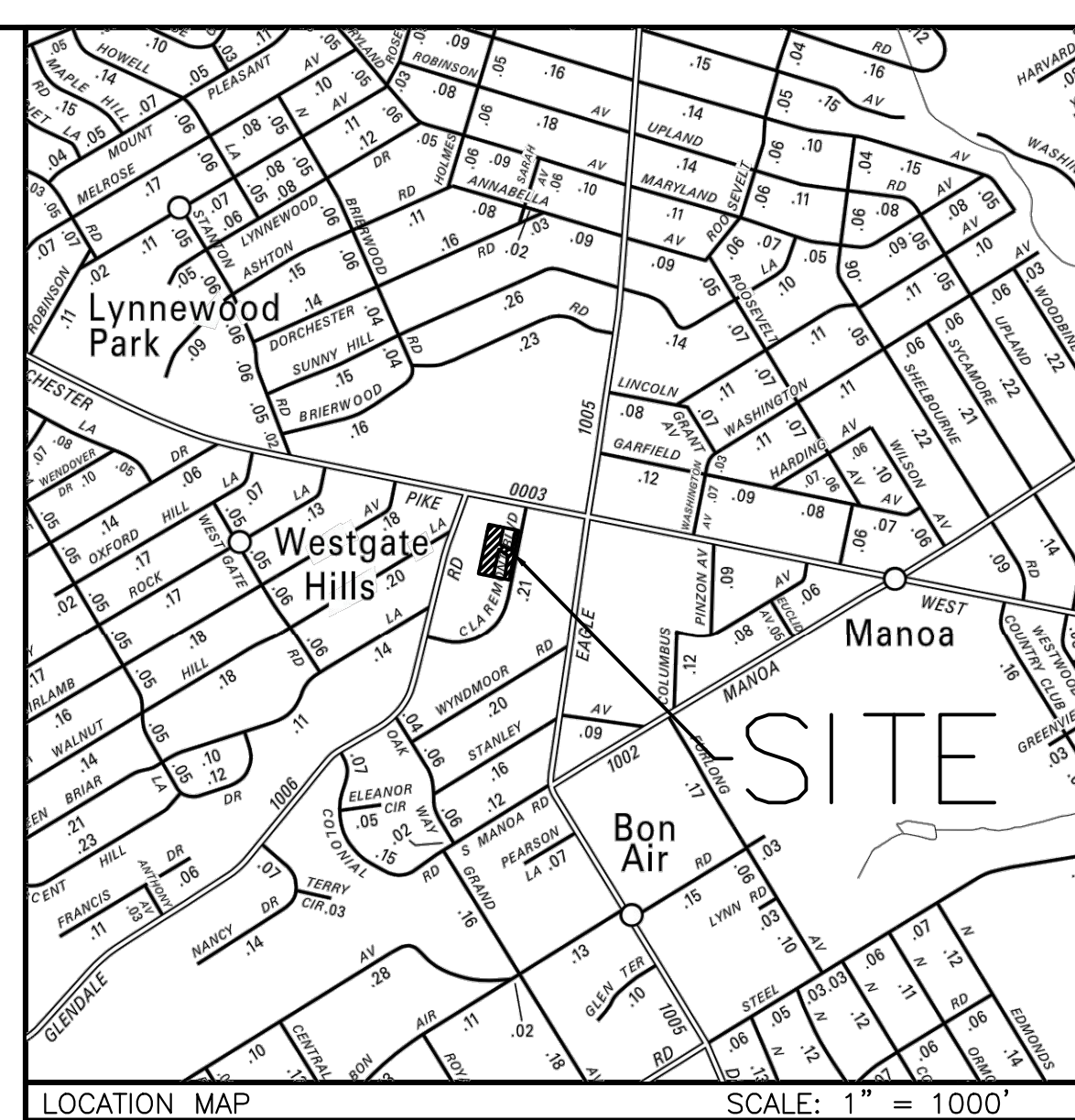
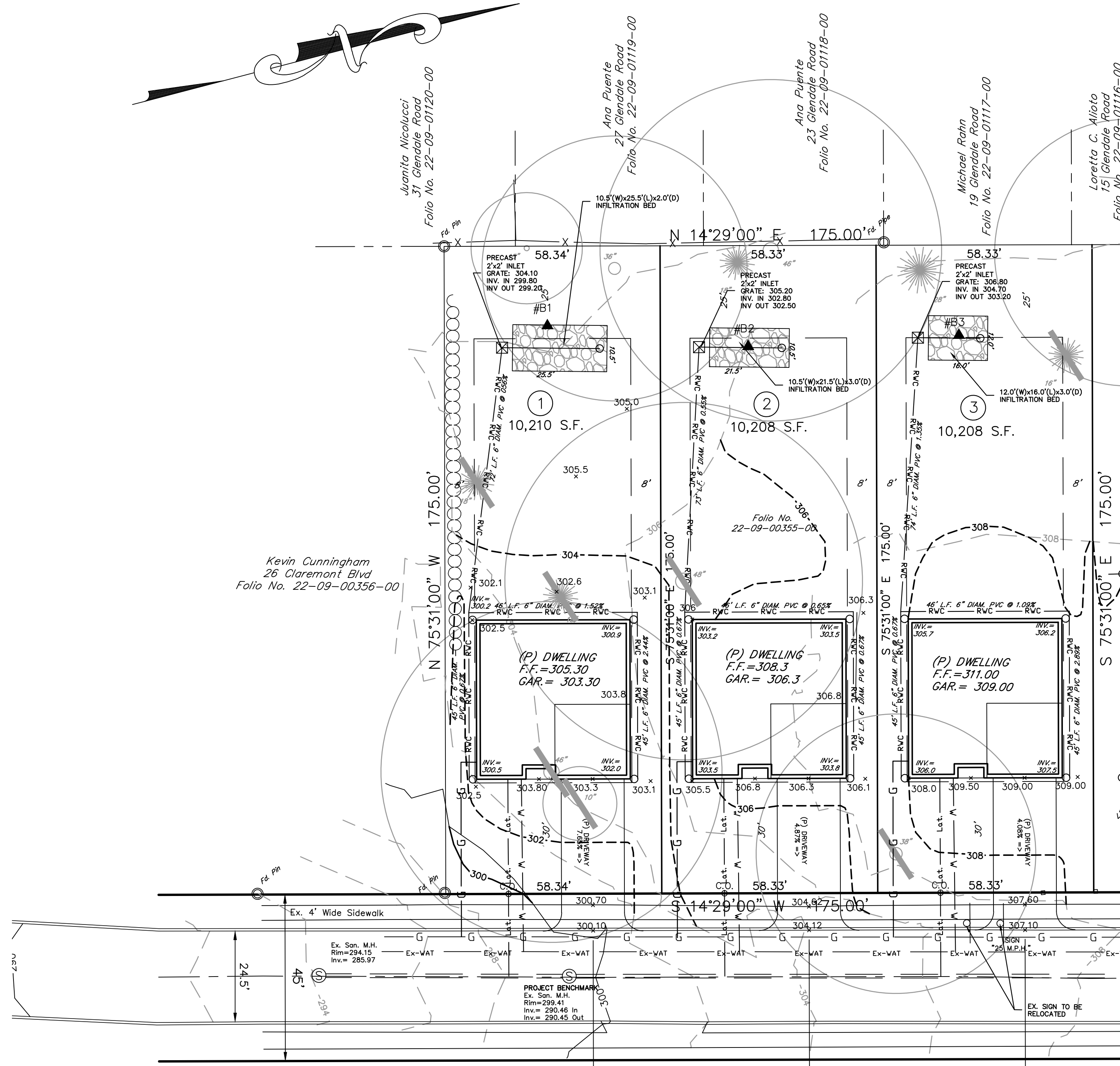

Kevin Cunningham
26 Claremont Blvd
Folio No. 22-09-00356-00

Juanita Nicoletti
31 Glendale Road
Folio No. 22-09-01120-00

Ana Puente
27 Glendale Road
Folio No. 22-09-01119-00

Ana Puente
23 Glendale Road
Folio No. 22-09-01118-00

Michael Rahn
19 Glendale Road
Folio No. 22-09-01117-00

Loretta C. Alitto
15 Glendale Road
Folio No. 22-09-01116-00

CLAREMONT BOULEVARD

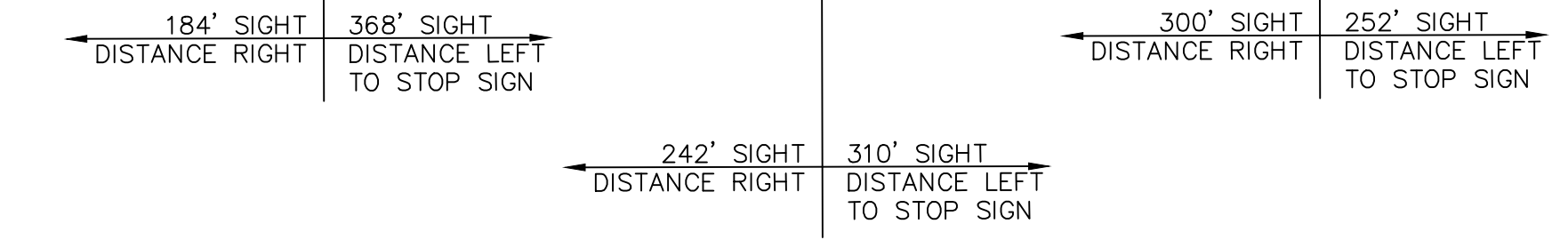

VEGETATION LOCATED WITHIN THE RIGHT-OF-WAY OF CLAREMONT BLVD. IS TO BE TRIMMED AS NECESSARY TO PROVIDE LISTED SIGHT DISTANCES

- LEGEND**
- EXISTING UTILITY POLE
 - EXISTING WATER VALVE
 - EXISTING DECIDUOUS TREE
 - EXISTING EVERGREEN TREE
 - DENOTES EXISTING TREE TO BE REMOVED
 - EXISTING 2' CONTOUR
 - EXISTING 10' CONTOUR
 - EXISTING INLET
 - EXISTING SANITARY MANHOLE
 - EXISTING SANITARY SEWER
 - EXISTING WATER MAIN
 - EXISTING WATER SERVICE
 - EXISTING GAS LINE
 - EXISTING FENCES
 - PERCOLATION TEST LOCATION
 - PROPOSED CONTOUR 2' INTERVAL
 - PROPOSED CONTOUR 10' INTERVAL
 - PROPOSED WATER SERVICE LINE
 - PROPOSED GAS LINE
 - PROPOSED SANITARY SEWER LATERAL
 - ROOF LEADER PIPE
 - PROPOSED SANITARY SEWER LATERAL CLEAN-OUT
 - PROPOSED 2'X2' INLET

DESIGN ENGINEERS CERTIFICATIONS:

- I hereby certify that the Stormwater Management Site Plan meets all design standards and criteria of the Haverford Township Stormwater Management Ordinance.
- The proposed grading activities shall not significantly increase stormwater runoff to, and/or otherwise adversely impact, downstream properties except as may be part of an approved Stormwater Management Plan (as defined by Haverford Township Code)
- The accuracy of this plan and details are in accordance with Act 367, known as the Professional Engineers Registration Law (P.L. 913, No. 367.63 P.S. 151), as amended.

I, Gustave N. Houtmann, P.E., on this date hereby certify, to the best of my knowledge and belief, that they aforementioned statements and certifications are true and accurate.

(Signature & Seal) _____ Date _____

The information shown on this plan is the result of a professional service rendered by G.D. Houtman & Son, Inc. Reproduction of this plan without approval of G.D. Houtman & Son, Inc. is not permitted. The reproduction of a copy of this plan for the purpose of creating additional copies or making a copy of this plan shall, in no circumstance, be approved. Certification for the work contained herein is limited to the entity for whom the work was performed as of the date shown on the plans.

Note: All locations of existing utilities shown on the plan have been developed from existing utility records and / or above ground examination of the site. Completeness or accuracy of locations and depth of underground utilities or structures cannot be guaranteed. Contractor must verify location and depth of all underground utilities and facilities before start of work, as per PA Act 181 as per the latest amendment of PA Act 287 of 1974, Effective Mar. 28, 2007.

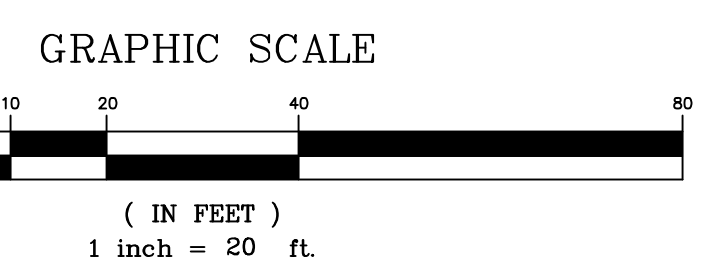

G. D. Houtman & Son, Inc. reserves its common law copyright and all other proprietary rights in these plans. All drawings, specifications and copies thereof are to remain property of G. D. Houtman & Son, Inc. They are to be used only in respect to this project. They are not to be assigned or represented to be suitable for reuse by owner or others on extensions of project or any other project. They are not to be assigned to any third party without first obtaining written permission by G.D. Houtman & Son, Inc. Any re-use without written permission for the specific purpose intended will be at the third party's sole risk and without liability or legal exposure to G. D. Houtman & Son, Inc. The third party shall further indemnify and hold harmless G. D. Houtman & Son, Inc. from all claims, damages, losses and expenses arising thereto or resulting therefrom.

These plans were prepared to obtain Subdivision/Land Development approval from the governing Municipality and to obtain certain permits from state and federal agencies. If a surveyor or engineer other than G. D. Houtman & Son, Inc. is contacted to perform construction stake-out services, soil survey or other engineering services, the responsibility for verifying dimensions, elevations, presence of underground utilities, utility interference, building size, etc. for coordinating information shown on lay-out plans, grading plans, utility plans, profiles, and details and for coordinating these plans with plans prepared by others such as utility companies, architectural building plans, landscape plans, lighting plans and etc.

| DATE | REVISION |
|-------------------|----------|
| November 30, 2023 | |

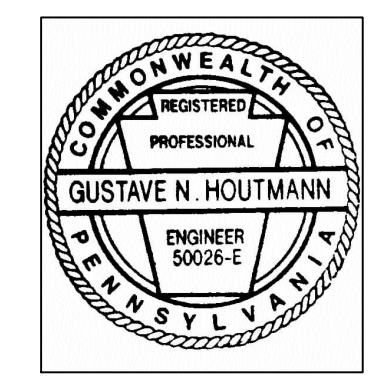

GRADING PLAN OF PROPERTY FOR
CARAMANICO HOMES, LLC
HAVERFORD TOWNSHIP
DELAWARE COUNTY, PA

G.D. HOUTMAN & SON, INC.
CIVIL ENGINEERS—LAND SURVEYORS
LAND PLANNERS
139 EAST BALTIMORE PIKE MEDIA, PA 19063
(610)565-4383

Sheet 3 of 6
PROJECT: Caramanico
WORK SHEET: 39258
FILE: 39258

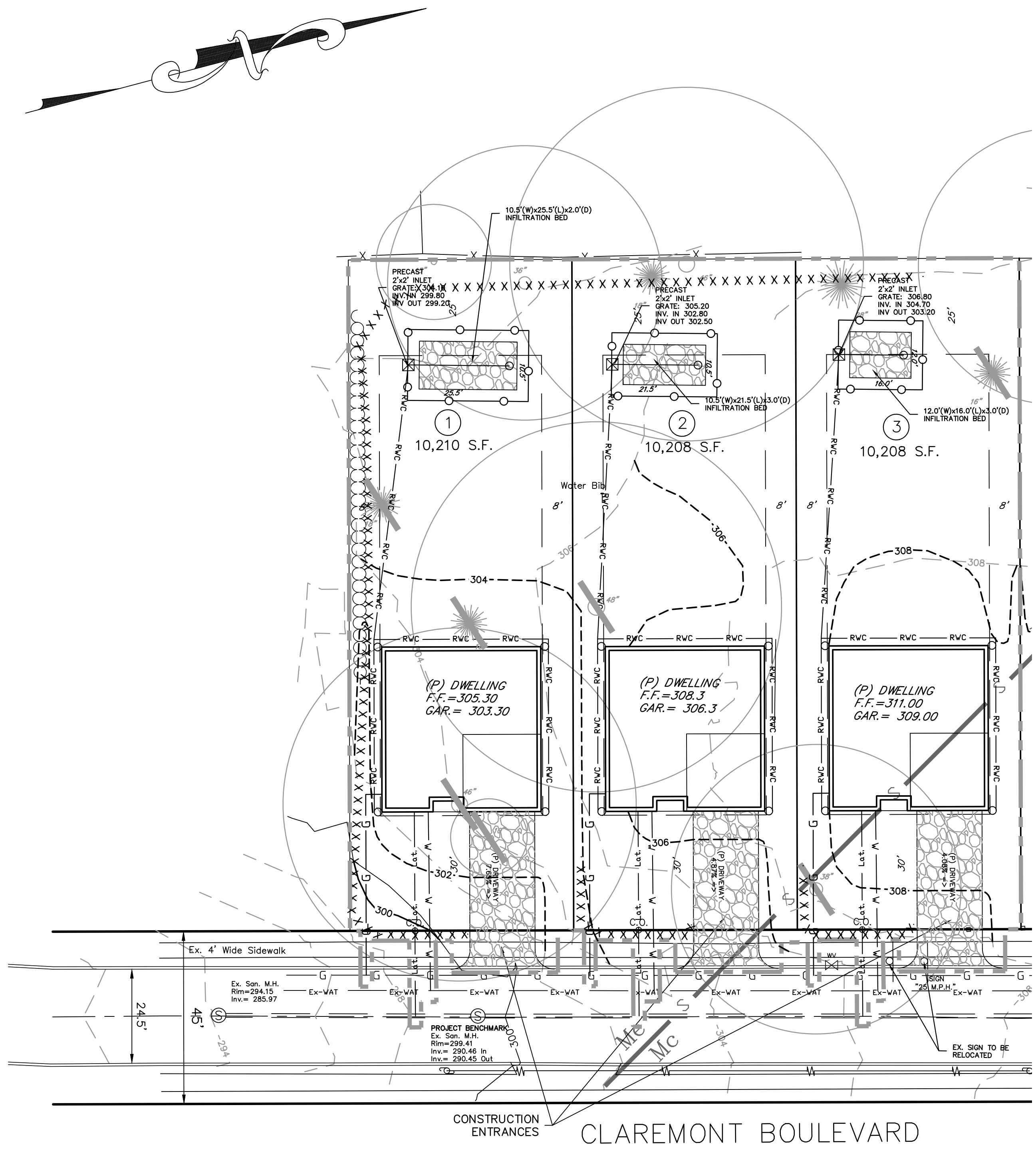

HOUSE CONSTRUCTION NOTES:

1. Install silt fence where shown on the plan. Install Construction Barrier Fencing at perimeter of infiltration beds. Construction vehicles shall not traverse over infiltration bed area. Infiltration bed areas shall remain undisturbed until bed is constructed.
2. Out in driveway, apply layer of crushed stone and maintain as construction access to the house site.
3. Construct house foundation. As soon as first floor decking is in place, backfill foundation and rough grade surrounding area.
4. Any topsoil stockpile generated by ITEMS 2 through 4 shall be placed in an area not subject to erosion and a silt fence barrier shall be installed and maintained around the downslope perimeter.
5. To all areas which earthmoving activities have ceased and will be subject to the action of earthmoving and other equipment, apply a mulch (wood chip - 2-3 tons per acre; hay or straw - 3 tons per acre). All other disturbed areas remaining open shall be temporarily seeded and mulched.
6. Contact the Township a minimum of 2 days Prior to the and Construct Infiltration Bed for roof drainage. Place orange construction fencing around infiltration bed area. Temporarily seal inlet grate with plywood and sealant. Sediment laden runoff must be prevented from flowing into the infiltration bed while the site remains disturbed.
7. Install underground utilities following procedures set forth in UTILITIES following final grading.
8. Complete house construction and discharge roof drains to infiltration bed system.
9. Permanent grass cover shall be established by seeding and mulching following final grading.
10. Driveway is to be stabilized with crushed stone or paving following the completion of the house construction. Stone filter berms may be incorporated into the driveway if relatively clean. Remove if choked with sediment.
11. Erosion and sediment control facilities are to be checked and properly maintained weekly and after each storm event. Sufficient quantities of silt fencing, crushed stone, straw bales, seeding and mulching should be readily available for remedial work if required.
12. Silt fencing may be removed when the site is stabilized. Accumulated sediment may be spread at the site in areas not subject to erosion.
13. The Contractor is advised to become familiar with the "Erosion and Sediment Pollution Control Program Manual" by the Commonwealth of PA., Department of Environmental Resources, April 2000 edition.
14. Copies of these plans must be available on site throughout construction.

SEEDING SPECIFICATIONS

- Disturbed areas on which activities have ceased must be stabilized immediately.
- I. Growing Season (March thru November 15)
 - A. Temporary Cover - for disturbed areas which are not at finished grade and which will be redisturbed within 1 year.
 1. Site Preparation: Apply 2 ton/acre of Agricultural grade limestone, plus fertilizer 50-50-50 per acre (50 lbs of N, 50 lbs of P2O5 and 50 lbs of K2O per acre) and work in where possible.
 2. Seeding: 50% Annual Ryegrass 50% Winter Rye. Apply at rate of 3lb/1000 S.F.
 3. Mulch: 3 tons per acre of small grain straw.
 - B. Permanent Cover - for disturbed areas at finish grade or will not be redisturbed within 1 year.
 1. Site Preparation: Re-apply topsoil to area. Apply 3 tons/acre of Agricultural grade Limestone plus Fertilizer 100-200-200 (100 lbs of N, 200 lbs of P2O5 and 200 lbs of K2O) and work in where possible.
 2. Seeding: 60% Kentucky Bluegrass
10% Perennial Ryegrass
30% Pennlawn Red Fescue
Apply at rate of 4 lb/1000 S.F.
 3. Mulch: 3 tons per acre of small grain straw.
 - II. Non-germinating Period (Nov 15 thru March 1)
 1. Apply mulch (3 tons per acre of small grain straw) to disturbed areas.
 2. Those areas that were stabilized by mulching only are to be limed, fertilized, seeded and mulched according to permanent or temporary seeding specifications at the end of the non-germinating period.

LEGEND

- EXISTING UTILITY POLE
- EXISTING WATER VALVE
- EXISTING DECIDUOUS TREE
- EXISTING EVERGREEN TREE
- DENOTES EXISTING TREE TO BE REMOVED
- EXISTING 2' CONTOUR
- EXISTING 10' CONTOUR
- EXISTING INLET
- EXISTING SANITARY MANHOLE
- EXISTING SANITARY SEWER
- EXISTING WATER MAIN
- EXISTING WATER SERVICE
- EXISTING GAS LINE
- EXISTING FENCES
- #1 PERCOLATION TEST LOCATION
- PROPOSED CONTOUR 2' INTERVAL
- PROPOSED CONTOUR 10' INTERVAL
- PROPOSED WATER SERVICE LINE
- PROPOSED GAS LINE
- PROPOSED SANITARY SEWER LATERAL
- ROOF LEADER PIPE
- PROPOSED SANITARY SEWER LATERAL CLEAN-OUT
- PROPOSED CONSTRUCTION FENCING
- PROPOSED SILT FENCE
- LIMIT OF DISTURBANCE (32,390 S.F.)
- PROPOSED 2'X2" INLET

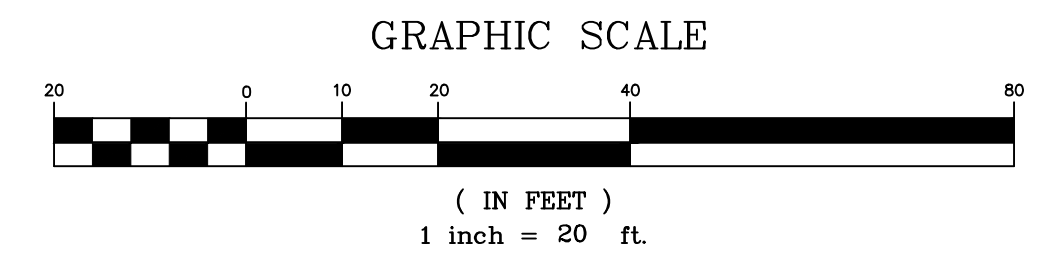

The information shown on this plan is the result of a professional service rendered by G.D. Houtman & Son, Inc. Reproduction of this plan without approval of G.D. Houtman & Son, Inc. is not permitted. The reproduction of a copy of this plan for the purpose of creating additional copies or retaining said plan shall, in no circumstance, be approved. Certification for the work contained herein is limited to the entity for whom the work was performed as of the date shown on the plans.

Note: All locations of existing utilities shown on the plan have been developed from existing utility records and / or above ground examination of the site. Completeness or accuracy of locations and depth of underground utilities or structures cannot be guaranteed. Contractor must verify location and depth of all underground utilities and facilities before start of work, as per PA Act 181 as per the latest amendment of PA Act 287 of 1974, Effective Mar. 28, 2007.

G. D. Houtman & Son, Inc. reserves its common law copyright and all other proprietary rights in these plans. All drawings, specifications and copies thereof are to remain property of G. D. Houtman & Son, Inc. They are to be used only in respect to this project. They are not to be assigned or represented to be suitable for reuse by owner or others on extensions of project or any other project. They are not to be assigned to any third party without first obtaining written permission by G.D. Houtman & Son, Inc. Any re-use without written permission for the specific purpose intended will be at the third party's sole risk and without liability or legal exposure to G. D. Houtman & Son, Inc. The third party shall further indemnify and hold harmless G. D. Houtman & Son, Inc. from all claims, damages, losses and expenses arising thereto or resulting therefrom.

These plans were prepared to obtain Subdivision/Land Development approval from the governing Municipality and to obtain certain permits from state and federal agencies. If a surveyor or engineer other than G. D. Houtman & Son, Inc. is contacted to perform construction stake-out services, sold surveyor or engineer shall assume the responsibility for verifying dimensions, elevations, presence of underground utilities, utility interferences, building size, etc. for coordinating information shown on lay-out plans, grading plans, utility plans, profiles, and details and for coordinating these plans with plans prepared by others such as utility companies, architectural building plans, landscape plans, lighting plans and etc.

| | | | | |
|---|----------|-------------------|---|---|
| DATE | REVISION | SCALE 1" = 20' | SEDIMENT & EROSION CONTROL PLAN OF PROPERTY FOR CARAMANICO HOMES, LLC HAVERFORD TOWNSHIP DELAWARE COUNTY, PA | Sheet 4 of 6 PROJECT Caramanico WORK SHEET 39258 FILE 39258 |
| November 30, 2023 | | | | |
| G.D. HOUTMAN & SON, INC. CIVIL ENGINEERS-LAND SURVEYORS LAND PLANNERS 139 EAST BALTIMORE PIKE MEDIA, PA 19063 (610)565-4383 | | | PROJECT Caramanico WORK SHEET 39258 FILE 39258 | |

TREE PROTECTION REQUIREMENTS

- Prior to any clearing or site disturbance, the Township requires a meeting with the applicant and/or site Contractor, to determine the methods to be implemented by the applicant to minimize tree loss. Application is required to follow standards as established in Section 170.
- All trees and other vegetation to be preserved shall be protected from damage by construction fencing or other effective barriers approved by the Township. Fencing or barriers around trees shall be placed outside the critical root zone, unless otherwise approved by the Township. Tree Protection fencing must be installed and approved by the Township prior to the start of any clearing or earth disturbance and monitored periodically. The tree protection fencing shall be removed only after all construction activities that may impact tree roots are completed.
- When disturbance within the critical root zone is unavoidable, applicants shall minimize encroachment and use the best available methods as approved by the Township to minimize damage and preserve trees. These methods may include, but shall not be limited to, utility tunneling, use of Geo-textiles, mulching, hand root pruning, and soil aeration. Applicants shall consult references such as a Guide to Preserving Trees in Development Projects, published by the Penn State College of Agricultural Sciences Cooperative Extension.

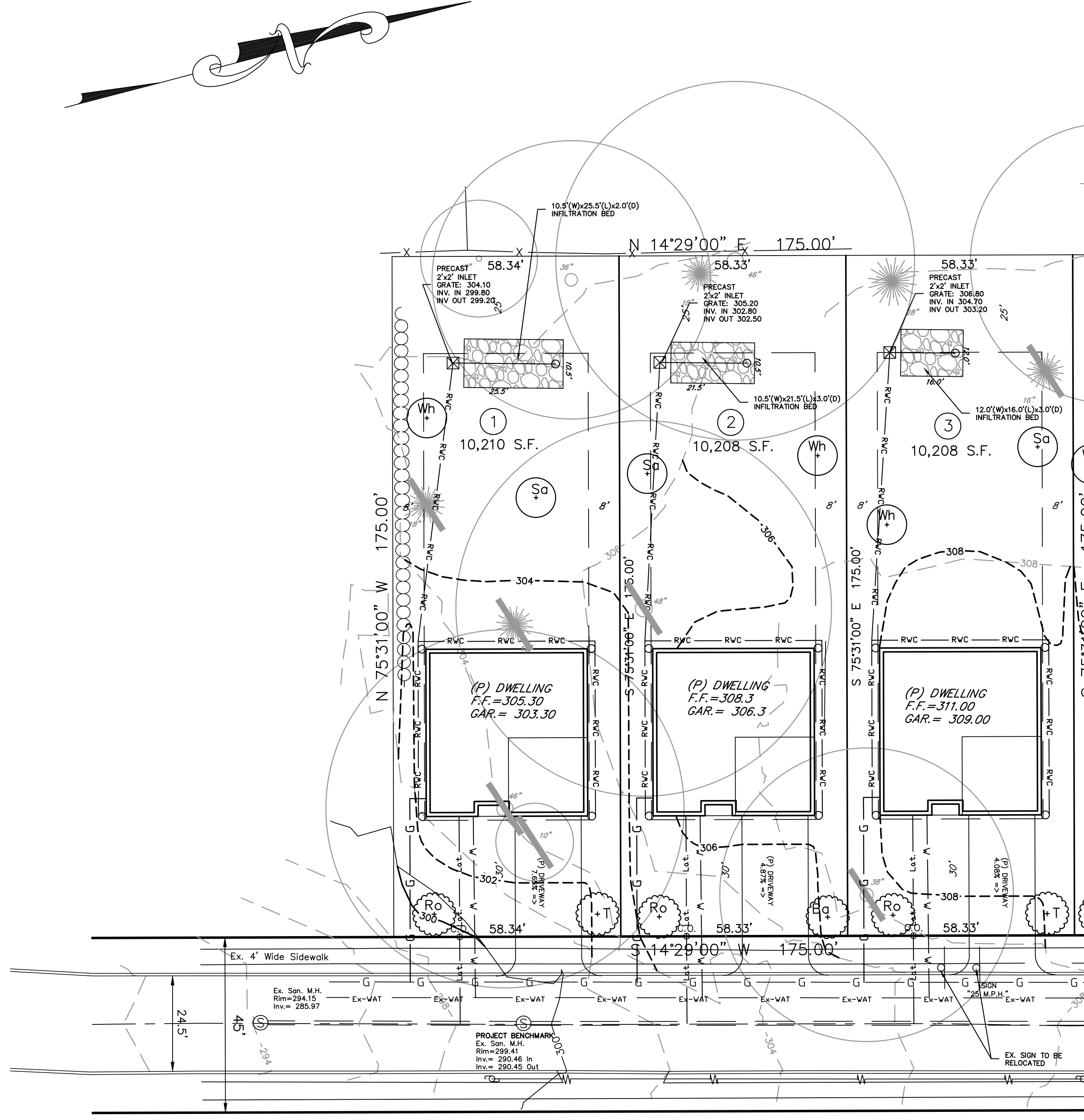
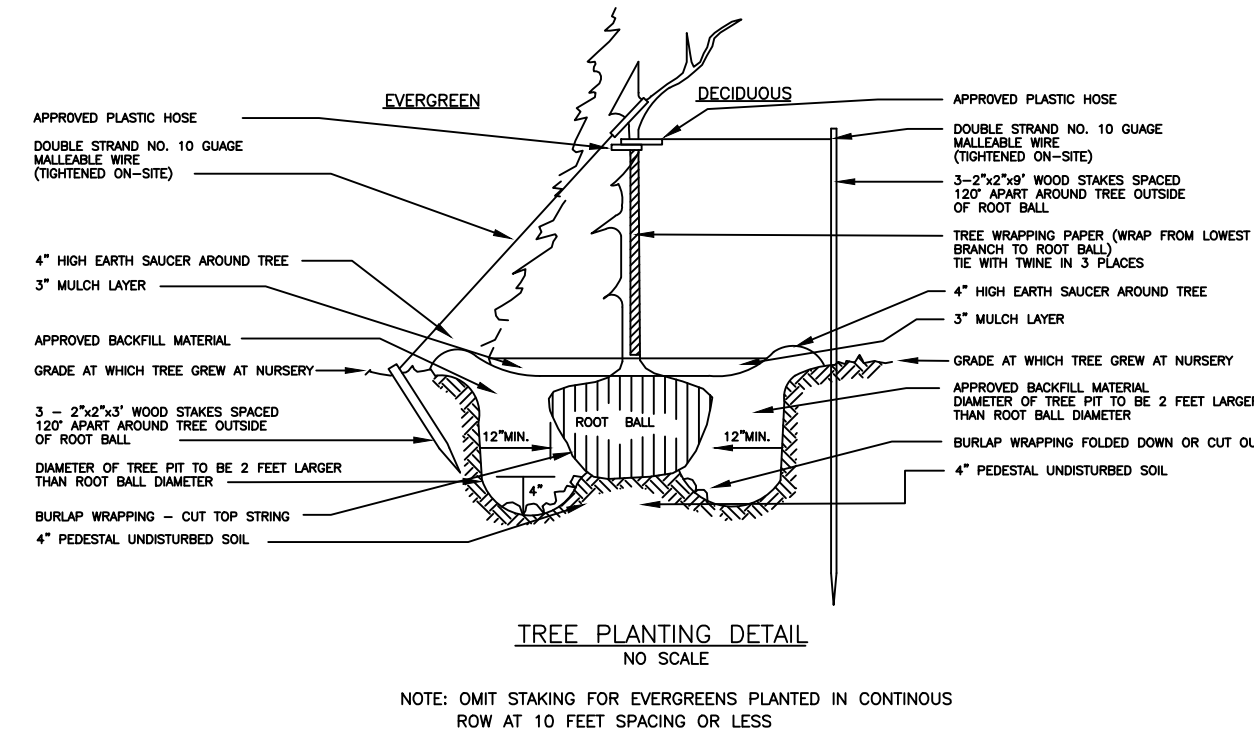

| TREES TO BE REMOVED | TOTAL TREE REMOVAL (DBH) | SECTION 170-2.A&B REPLACEMENT REQUIREMENTS | REQUIRED TREE DIAM. REPLACEMENT | REQUIRED EQUIVALENT 2" DIAM. REPLACEMENT |
|-----------------------|--------------------------|---|---------------------------------|--|
| LESS THAN 30" DBH (*) | 62" | 1" OF REPLACEMENT TREE DIAM. FOR EVERY 4" REMOVED | 16" | 8 |
| 10" - 1 | | | | |
| 16" - 1 | | | | |
| 18" - 2 | | | | |
| 30" DBH AND GREATER | 132" | 1" OF REPLACEMENT TREE DIAM. FOR EVERY 1" REMOVED | 132" | 66 |
| 48" - 1 | | | | |
| 46" - 1 | | | | |
| 38" - 1 | 74 | | | |

GRAND TOTAL TREE REMOVAL = 7

(**) A Payment for Fee-In-Lieu of Tree Replacement Will Be Provided by the Developer for the 60 Replacement Trees Not Being Planted in Accordance with Section 170-4B.(7).

PROPOSED PLANTINGS:

STREET TREES:

| SYMBOL | QUANTITY | BOTANIC/Common Name | SIZE | SPECS |
|--------|----------|-----------------------------------|-----------|-------|
| Ro | 3 | Quercus rubra Red Oak | 2.0" Cal. | B&B |
| Ba | 1 | Tilia americana Bosswood | 2.0" Cal. | B&B |
| T | 2 | Liliodendron tulipifera Tulipwood | 2.0" Cal. | B&B |

PROPOSED NUMBER OF STREET TREES = 6

REPLACEMENT TREES:

| SYMBOL | QUANTITY | BOTANIC/Common Name | SIZE | SPECS |
|--------|----------|--------------------------------|-----------|-------|
| Wh | 3 | Platanus occidentalis Sycamore | 2.0" Cal. | B&B |
| Sa | 3 | Sassafras albidum Sassafras | 2.0" Cal. | B&B |

PROPOSED NUMBER OF REPLACEMENT TREES = 6

LANDSCAPING NOTES:

- Preservation: The landowner or developer shall protect trees to be retained from damage during construction. The following procedures shall be followed in order to so protect such trees:
 - Shade trees of twelve (12) inch caliper or more shall be preserved.
 - No more than five (5) inches of soil shall be placed around the trunks of trees, which are to remain. For those trees, which are to remain, where more than five (5) inches of soil are to be placed, tree wells shall be constructed to preserve such trees.
 - Trees to remain shall be protected by wooden silt snow fencing, placed around such trees. Fencing to be placed beyond the critical root zone of the tree(s) to be preserved (measured 12 times the trunk diameter or to the dripline, whichever is greater). Fencing shall be maintained throughout the construction period.
 - Trees shall not be used for roping, cables, signs, or fencing. Nails and spikes shall not be driven into trees.
 - Heavy equipment operators shall avoid damaging existing tree trunks and roots. Feeder roots shall not be cut or disturbed within the area circumscribed by the drip line of any tree.
 - No disturbance, material stockpiling, foot or vehicle traffic, excavation or fill shall be permitted within the critical root zone.
 - Tree limbs damaged during construction shall be sawed flush to tree trunks and treated with tree paints as necessary.
 - Deciduous trees shall be given a heavy application of fertilizer to aid in their recovery from possible damage caused by construction operations.
- Plant Characteristics and Maintenance
 - All plants shall conform to the "American Standards for Nursery Stock" of the American Association of Nurserymen.
 - Trees and shrubs shall be typical of their species and variety, have normal growth habits, well developed, densely foliated branches, and vigorous, fibrous root systems.
 - Trees and shrubs shall be free from defects and injuries and certified by appropriate Federal and State Authorities to be free from diseases and insect infestations.
 - Trees and shrubs shall be freshly dug and nursery grown. They shall have been grown under climatic conditions similar to those in the locality of the project or properly acclimated to conditions of the locality of the project.
 - The landowner or developer shall replace any tree or shrub, which dies within the term of a maintenance agreement. Any tree or shrub, which is deemed, in the opinion of the township, not to have survived or grown in a manner characteristic of its type, shall be replaced. Substitutions for certain species of plants may only be made when approved by the Board of Supervisors.
 - It shall be the responsibility of the landowners, tenants and/or other occupants of the premises to adequately and properly maintain the landscaped areas, which responsibility shall include watering, cleaning of weeds and debris, pruning and trimming, replacement of dead or diseased plantings, and fertilizing to maintain healthy growth.
 - All trees along the right-of-way of any property shall be kept trimmed nine (9) feet above any sidewalk and eleven (11) feet above all streets.
 - All shrubs and other growth abutting any sidewalks shall be kept cut back six (6) inches from the edge of the sidewalks.
 - Existing trees and shrubs at the corner of an intersection of streets and/or driveways, shall be cut to the height of 24 ins. from point of intersection of corner property lines back 50 ft. to avoid blocking sight distance to oncoming traffic; and shrubs or groundcovers to be planted shall be of the dwarf variety and shall not exceed 24 ins. height at maturity.

CLAREMONT BOULEVARD

LEGEND

| | | | |
|--|-------------------------------------|--|---|
| | EXISTING UTILITY POLE | | PERCOLATION TEST LOCATION |
| | EXISTING WATER VALVE | | PROPOSED CONTOUR 2' INTERVAL |
| | EXISTING DECIDUOUS TREE | | PROPOSED CONTOUR 10' INTERVAL |
| | EXISTING EVERGREEN TREE | | PROPOSED WATER SERVICE LINE |
| | DENOTES EXISTING TREE TO BE REMOVED | | PROPOSED GAS LINE |
| | EXISTING 2' CONTOUR | | PROPOSED SANITARY SEWER LATERAL |
| | EXISTING 10' CONTOUR | | ROOF LEADER PIPE |
| | EXISTING INLET | | PROPOSED SANITARY SEWER LATERAL CLEAN-OUT |
| | EXISTING SANITARY MANHOLE | | |
| | EXISTING SANITARY SEWER | | |
| | EXISTING WATER MAIN | | |
| | EXISTING WATER SERVICE | | |
| | EXISTING GAS LINE | | |
| | EXISTING FENCES | | |

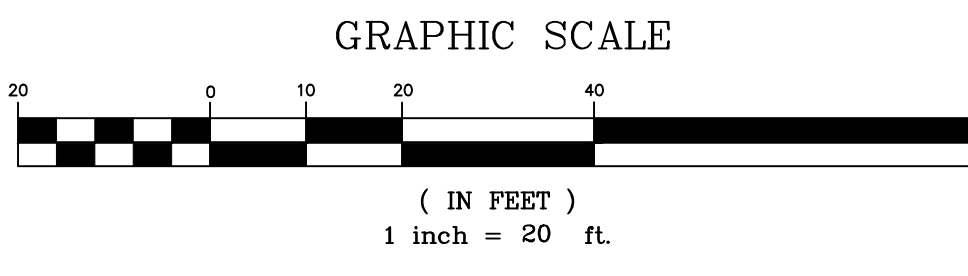

The information shown on this plan is the result of a professional service rendered by G.D. Houtman & Son, Inc. Reproduction of this plan without approval of G.D. Houtman & Son, Inc. is not permitted. The reproduction of a copy of this plan for the purpose of creating additional copies or retaining said plan shall, in no circumstance, be approved. Certification for the work contained herein is limited to the entity for whom the work was performed as of the date shown on the plans.

Note: All locations of existing utilities shown on the plan have been developed from existing utility records and / or above ground examination of the site. Completeness or accuracy of locations and depth of underground utilities or structures cannot be guaranteed. Contractor must verify location and depth of all underground utilities and facilities before start of work, as per PA Act 181 as per the latest amendment of PA Act 287 of 1974, Effective Mar. 28, 2007.

G. D. Houtman & Son, Inc. reserves its common law copyright and all other proprietary rights in these plans. All drawings, specifications and copies thereof are to remain property of G. D. Houtman & Son, Inc. They are to be used only in respect to this project. They are not intended or represented to be suitable for reuse by owner or others on extensions of project or any other project. They are not to be assigned to any third party without first obtaining written permission by G.D. Houtman & Son, Inc. Any re-use without written permission for the specific purpose intended will be at the third party's sole risk and without liability or legal exposure to G. D. Houtman & Son, Inc. The third party shall further indemnify and hold harmless G. D. Houtman & Son, Inc. from all claims, damages, losses and expenses arising thereto or resulting therefrom.

These plans were prepared to obtain Subdivision/Land Development approval from the governing Municipality and to obtain certain permits from state and federal agencies. If a surveyor or engineer other than G. D. Houtman & Son, Inc. is contacted to perform construction stake-out services, said surveyor or engineer shall assume the responsibility for verifying dimensions, elevations, presence of underground utilities, utility interference, building size, etc. for coordinating information shown on lay-out plans, grading plans, utility plans, profiles, and details and for coordinating these plans with plans prepared by others such as utility companies, architectural building plans, landscape plans, lighting plans and etc.

| DATE | REVISION | SCALE | LANDSCAPE & TREE REPLACEMENT PLAN OF PROPERTY FOR |
|------|----------|------------------|---|
| | | 1" = 20' | |
| | | DATE | Haverford Township Delaware County, PA |
| | | October 20, 2021 | G.D. HOUTMAN & SON, INC. |
| | | | CIVIL ENGINEERS-LAND SURVEYORS |
| | | | 139 EAST BALTIMORE PIKE MEDIA, PA 19063 |
| | | | Sheet 5 of 6 |
| | | | PROJECT WORK SHEET |
| | | | Caramanico |
| | | | 39258 |
| | | | FILE |
| | | | 39258 |

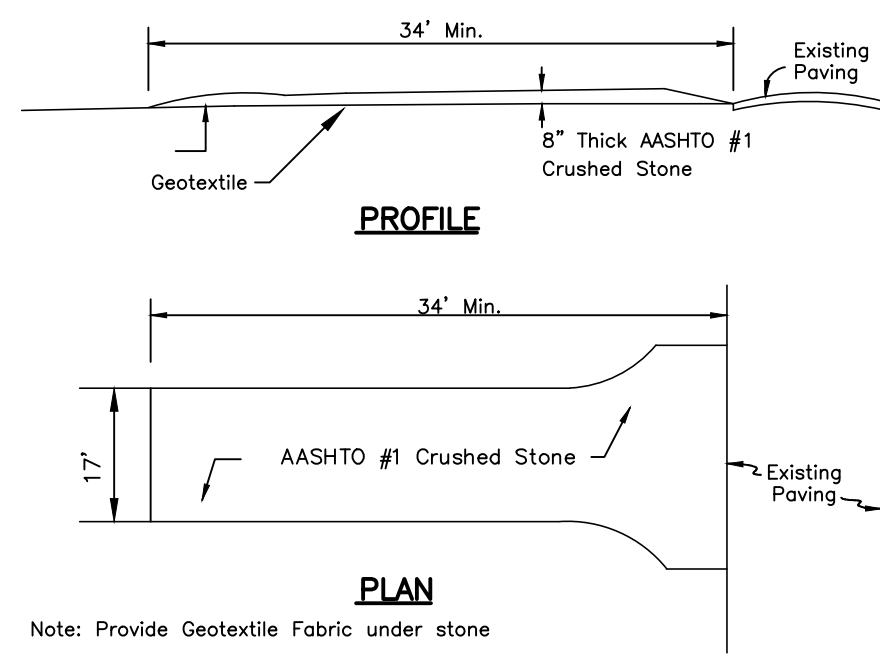

Maintenance Notes:
 1. Rock Construction Entrance Thickness Shall Be Constantly Maintained To The Specified Dimensions By Adding Rock.
 2. A Stockpile Shall Be Maintained On-Site For This Purpose.
 3. At The End Of Each Construction Day, All Sediment Deposited On Paved Roadways Shall Be removed and Returned To The Construction Site.

CONSTRUCTION ENTRANCE - DETAIL

Note: Rock Construction entrance to be adjusted for site conditions as necessary

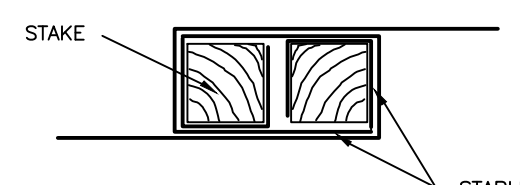

JOINING FENCE SECTIONS

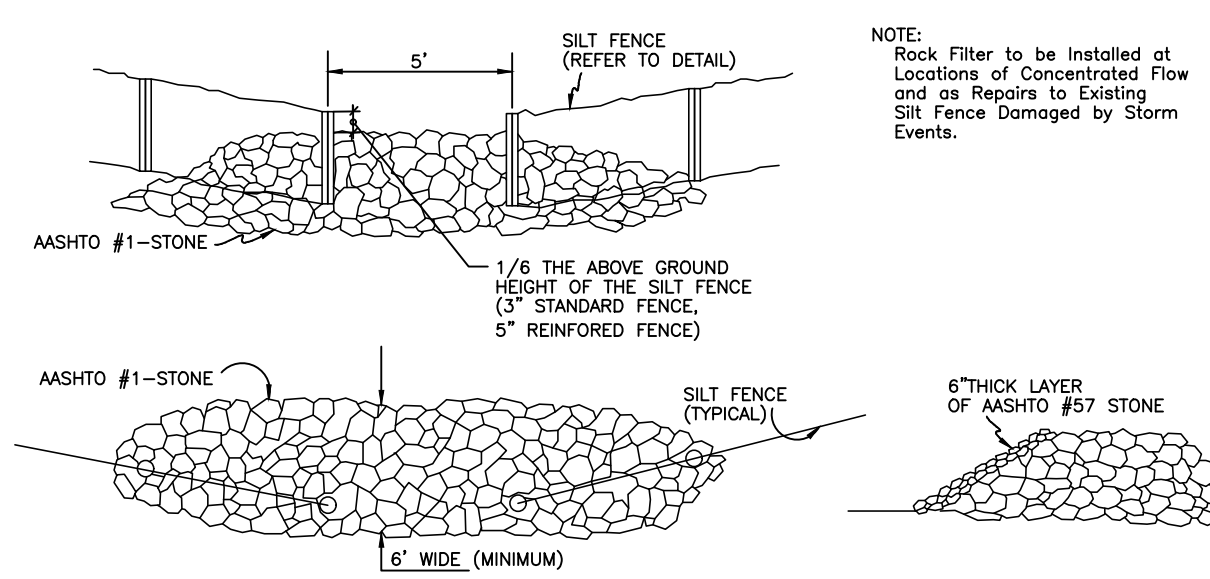

ROCK FILTER OUTLET FOR SILT FENCE

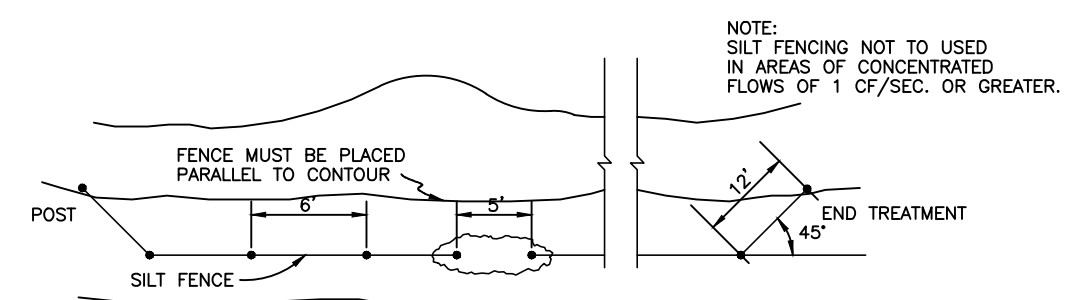

TEMPORARY SILT FENCE INSTALLATION

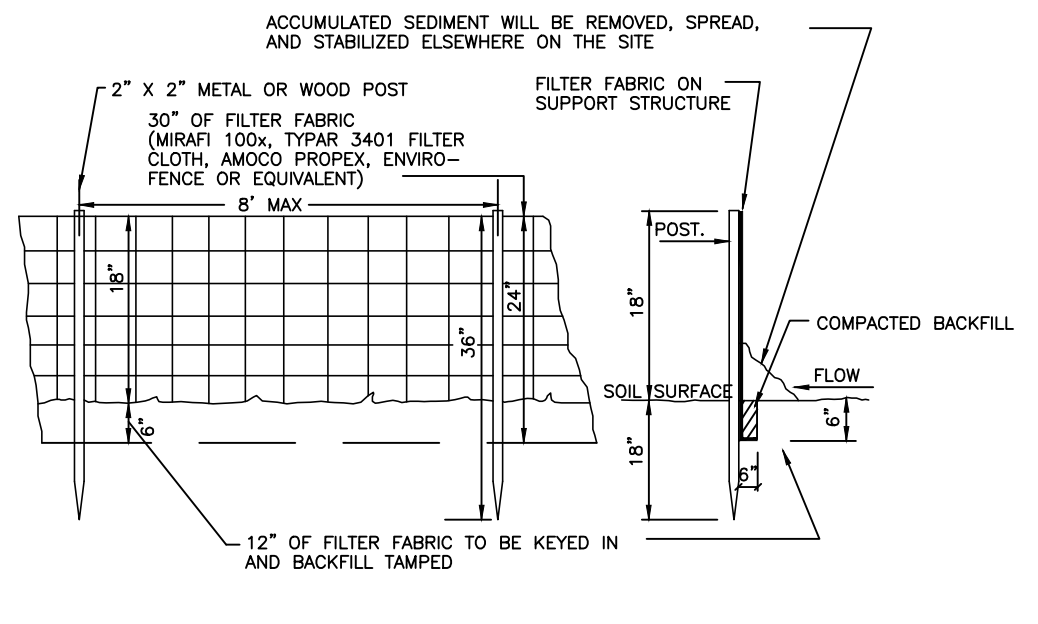

TEMPORARY SILT FENCE DETAIL

INSPECT SILT FENCING AFTER EACH STORM EVENT. REMOVE ACCUMULATED SEDIMENT WHEN IT REACHES A DEPTH OF 1/2 THE FABRIC HEIGHT (MAXIMUM 12"). ANY SILT FENCING WHICH HAS BEEN TOPPED OR UNDERMINED SHALL BE REPLACED WITH ROCK FILTER OUTLETS IMMEDIATELY.

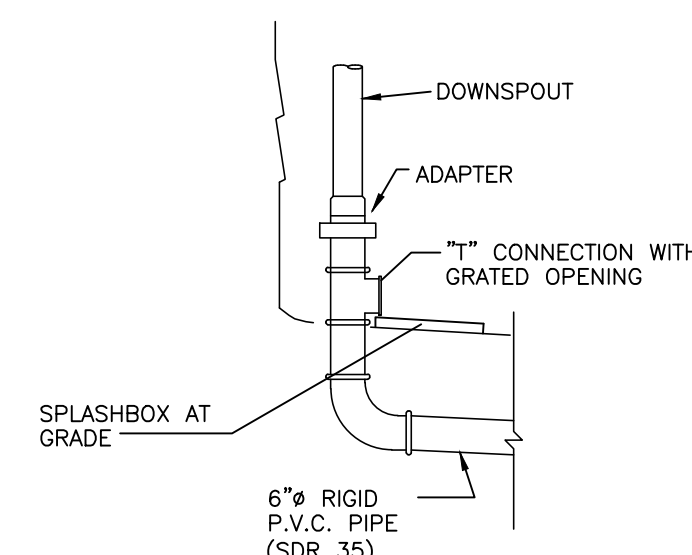

ROOF DRAIN CONNECTION DETAIL

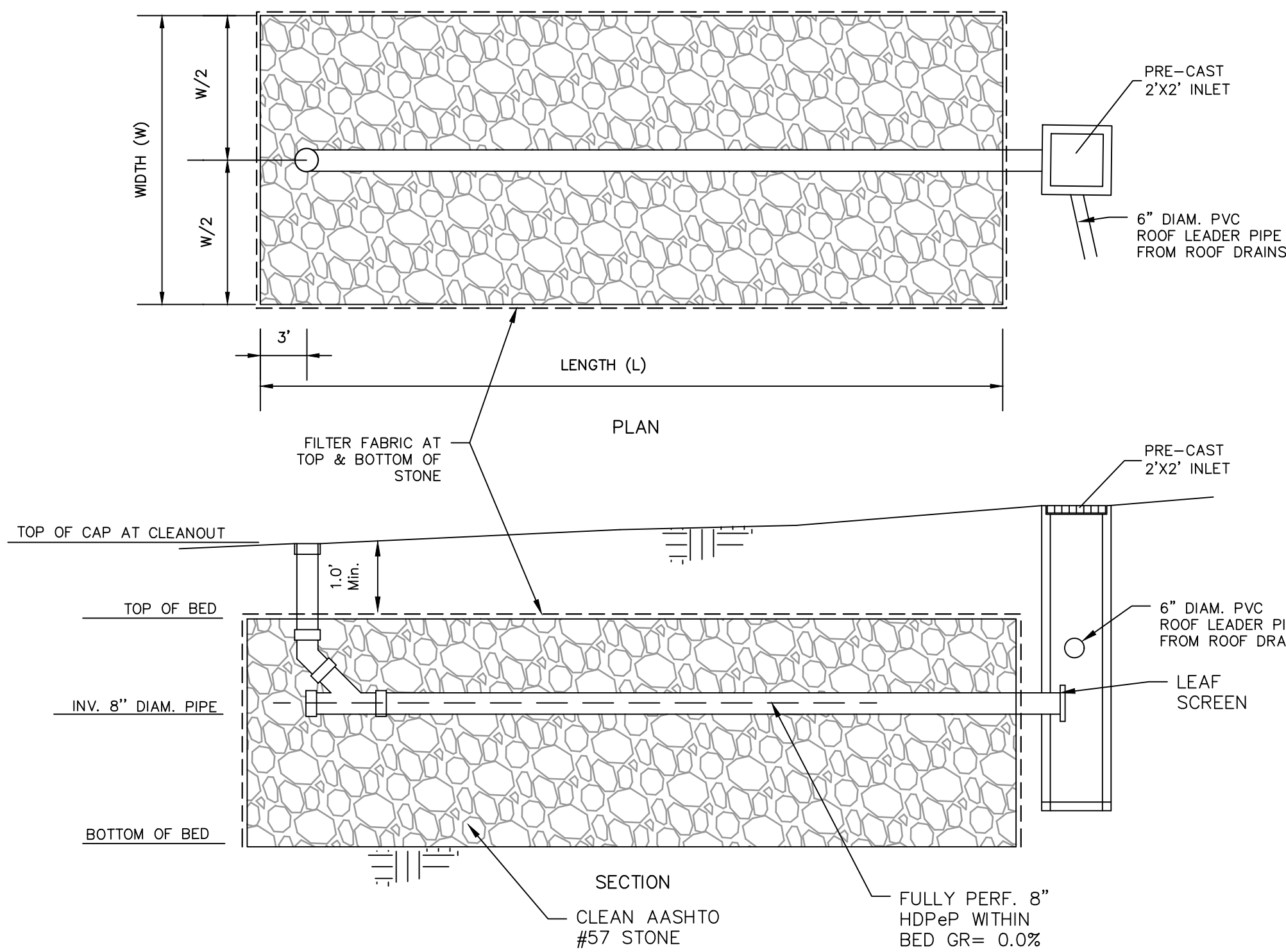

| LOCATION | TOP OF GRATE ELEV. | INV. PIPE TO BED ELEV. | TOP OF BED ELEV. | BOTTOM OF BED ELEV. | BED LENGTH (L) | BED WIDTH (W) | BED DEPTH (D) | TOP OF CLEAN-OUT ELEV. |
|----------|--------------------|------------------------|------------------|---------------------|----------------|---------------|---------------|------------------------|
| LOT #1 | 304.1 | 299.2 | 300.2 | 298.2 | 10.5' | 25.5' | 2.0' | 304.7 |
| LOT #2 | 305.2 | 302.5 | 304.0 | 301.0 | 10.5' | 21.5' | 3.0' | 306.2 |
| LOT #3 | 306.8 | 303.2 | 304.7 | 301.7 | 12.0' | 16.0' | 3.0' | 306.7 |

- NOTES:
 1. TOWNSHIP SHALL BE NOTIFIED A MINIMUM OF 48 HOURS PRIOR TO CONSTRUCTION FOR INSPECTION.
 2. ALL EQUIPMENT SHALL BE KEPT OFF INFILTRATION BED AREA TO PREVENT ANY COMPACTION.
 3. GEOTEXTILE SHALL BE PLACED AT ALL STONE/SOIL INTERFACES AT THE TOP AND SIDES OF THE INFILTRATION BED.
 4. ALL GEO-TEXTILE SHALL CONFORM TO P.A.D.O.T. CLASS 1 SPECIFICATIONS AND SHALL HAVE A MINIMUM OVERLAP OF 12".
 5. ALL STONE SHALL BE CLEAN WASHED AASHTO #57 STONE.
 6. ALL PIPE WITHIN STONE SHALL BE FULLY PERFORATED AND SHALL BE RIDGED SCHD. 40 PVC OR SDR 35 PIPE OR ADS N-12 PIPE. ALL OTHER PIPE SHALL BE RIGID SOLID SCHD 40 PVC, SDR 35 PIPE OR ADS N-12 PIPE.
 7. BOTTOM OF BED SHALL BE SCARIFIED PRIOR TO THE PLACEMENT OF STONE.
 8. ALL ROOF DRAINS SHALL BE PIPED DIRECTLY TO INFILTRATION BED.
 9. LEAF SCREEN SHALL BE PROVIDED ON ALL OUTLET PIPES TO INFILTRATION BED

INFILTRATION BED DETAIL

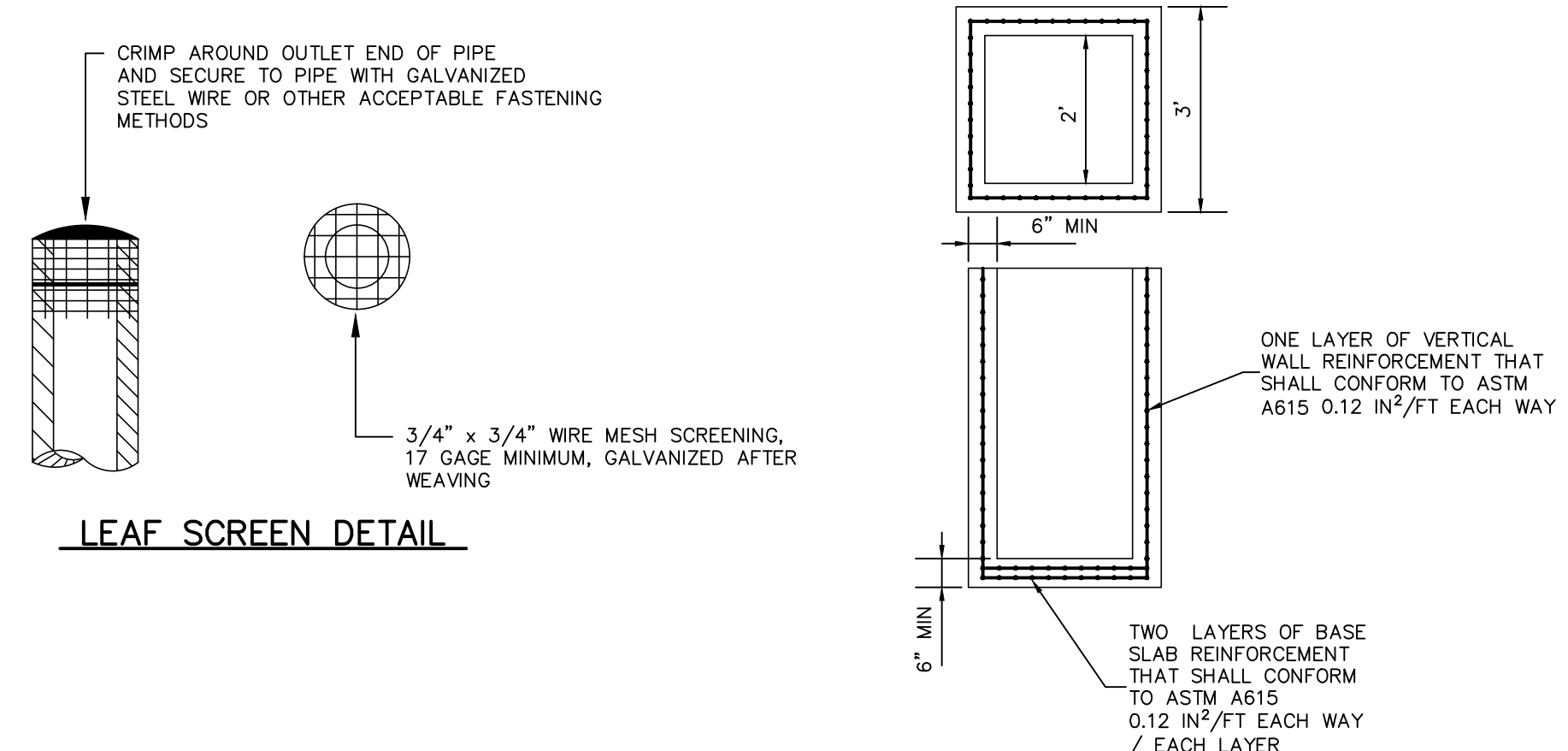

LEAF SCREEN DETAIL

Anchor Posts Must be a Minimum 2 In. Steel 'L' Channel, or 2x2 In. Wood Stakes 6 Feet in Length.

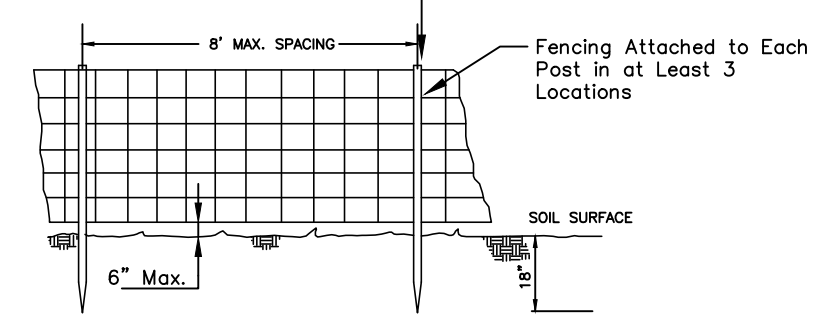

- NOTES:
 1. Protection barrier to be installed at the dripline of proposed individual trees and protected forested areas.
 2. Anchor post to be driven into the ground at least 18 inches.
 3. Provide a maximum clearance between the protection barrier fencing and the ground surface of 6 inches.
 4. Protection barrier shall be 4 feet high, constructed of durable and highly visible material (Plastic orange construction fence and snow-fence may be used).
 5. Protection barriers shall be maintained throughout the duration of the work at the site.
 6. Additional warning signs should also be placed on the fencing and in appropriate areas near the work zone.

TREE PROTECTION/CONSTRUCTION FENCING DETAIL

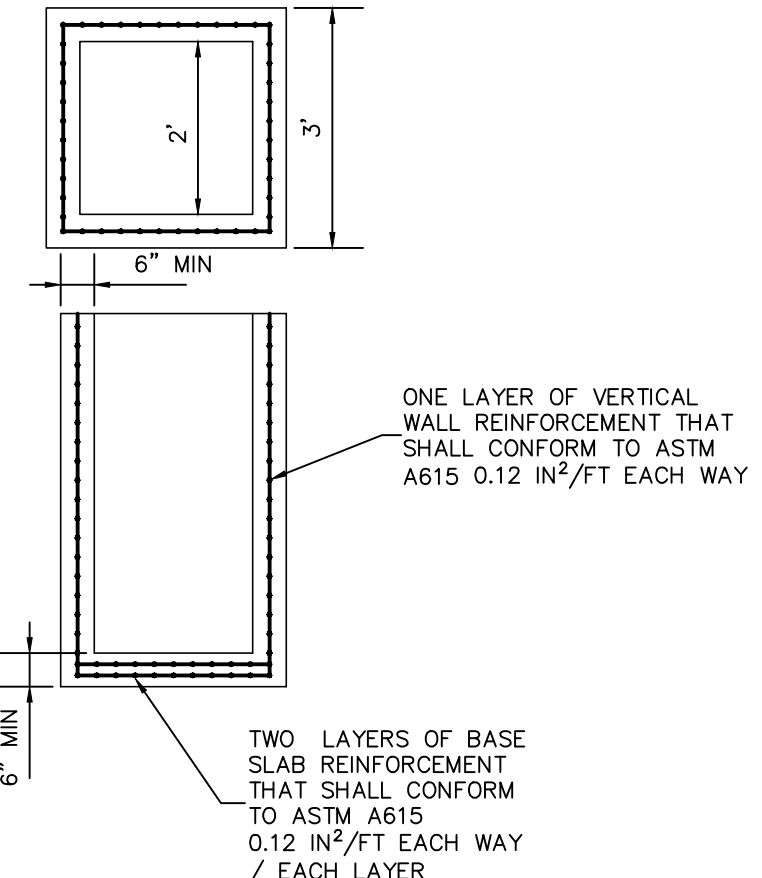

- NOTES:
 1. MATERIAL AND CONSTRUCTION SHALL COMPLY WITH PENN D.O.T. PUB. 408
 2. CLASS AA CONCRETE 4000 PSI @ 28 DAYS
 3. REINFORCEMENT SHALL COMPLY WITH ASTM A615

2'x2' PRE-CAST INLET DETAIL

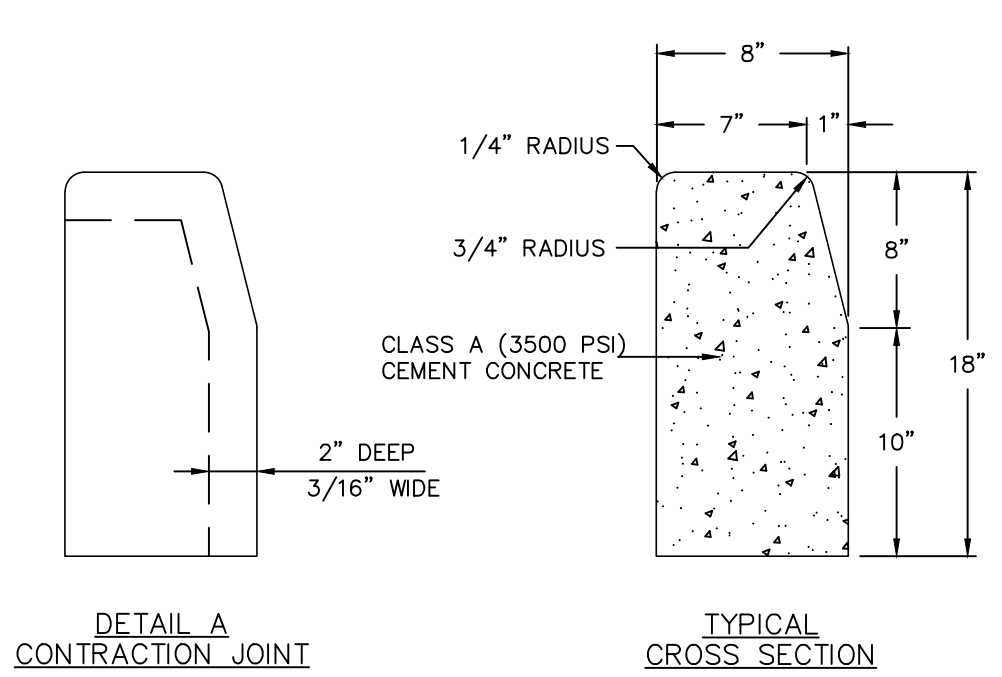

DETAIL A CONTRACTION JOINT

TYPICAL CROSS SECTION

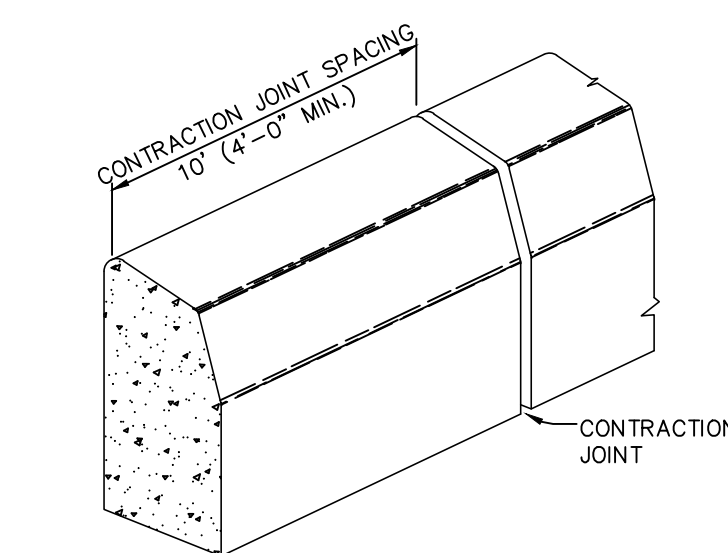

PLAIN CEMENT CONCRETE CURB

NOT TO SCALE

NOTE:
 1. Concrete to have minimum 28 day compressive strength of 3,750 psi.

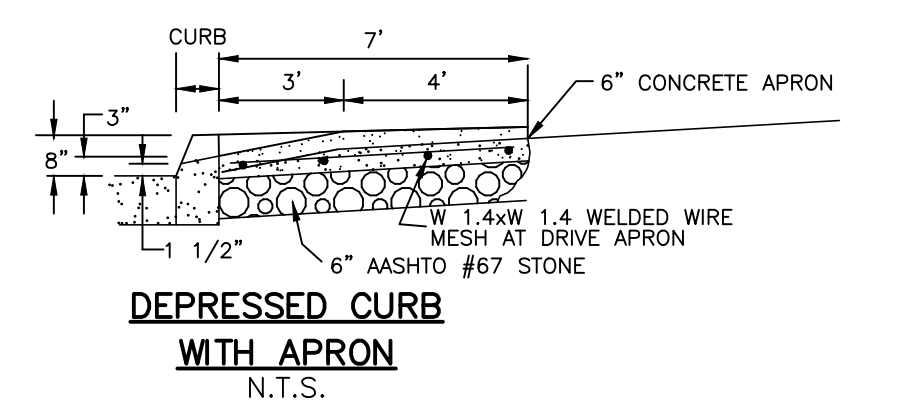

DEPRESSED CURB WITH APRON

N.T.S.

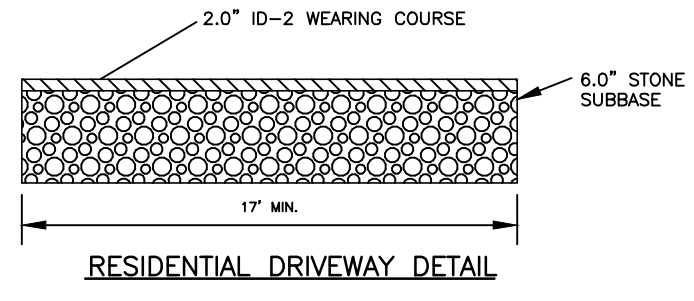

RESIDENTIAL DRIVEWAY DETAIL

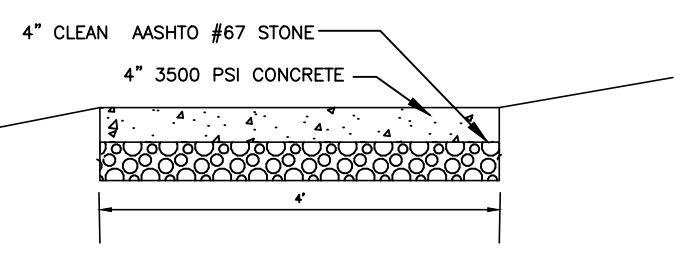

SIDEWALK DETAIL

NOTE:
 1. Concrete to have minimum 28 day compressive strength of 3,750 psi.

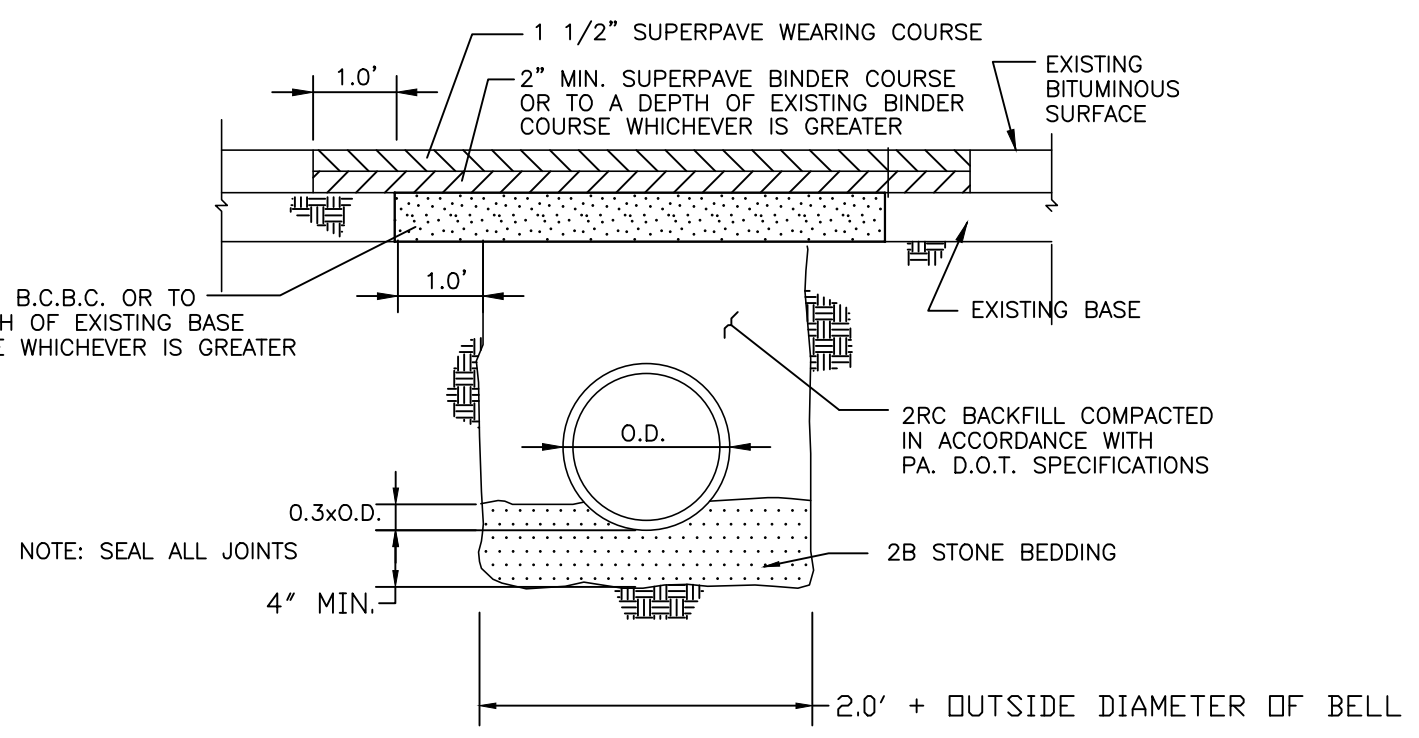

TOWNSHIP ROAD TRENCHING AND RESTORATION DETAIL

NOTE: EXPOSED VERTICAL AND HORIZONTAL SURFACES SHALL BE PREPARED AS PER PUB. 408, SECT. 401.3(f).

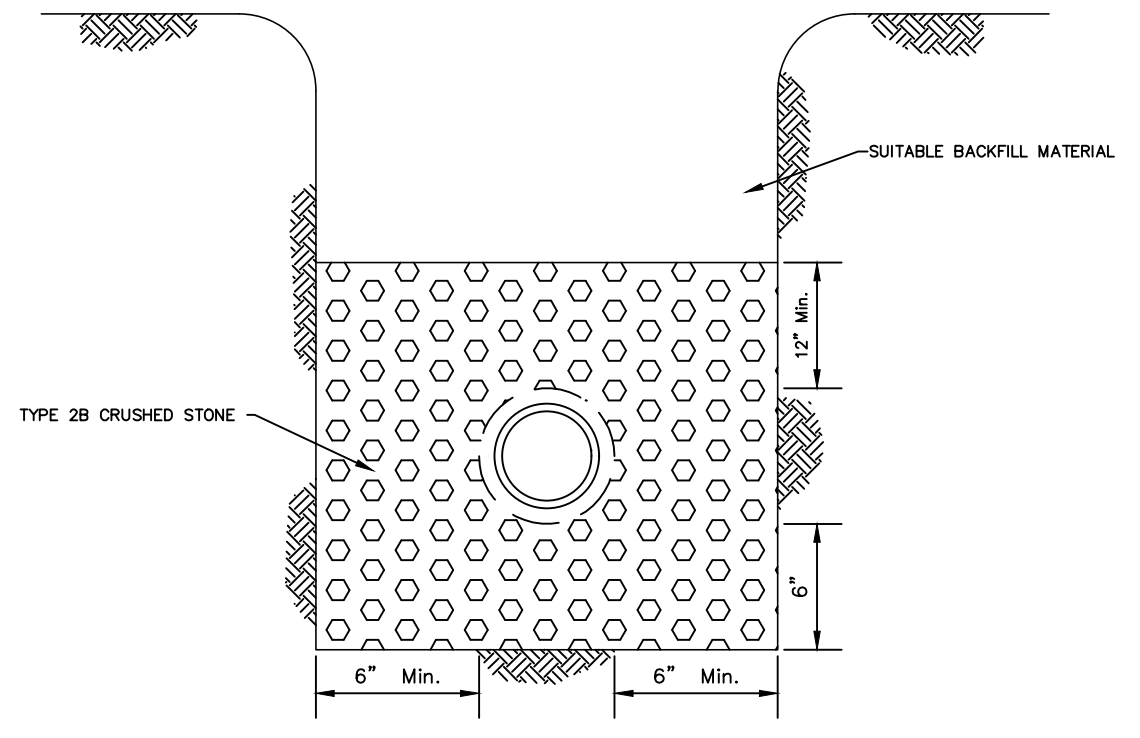

TYPICAL SANITARY SEWER BEDDING DETAIL

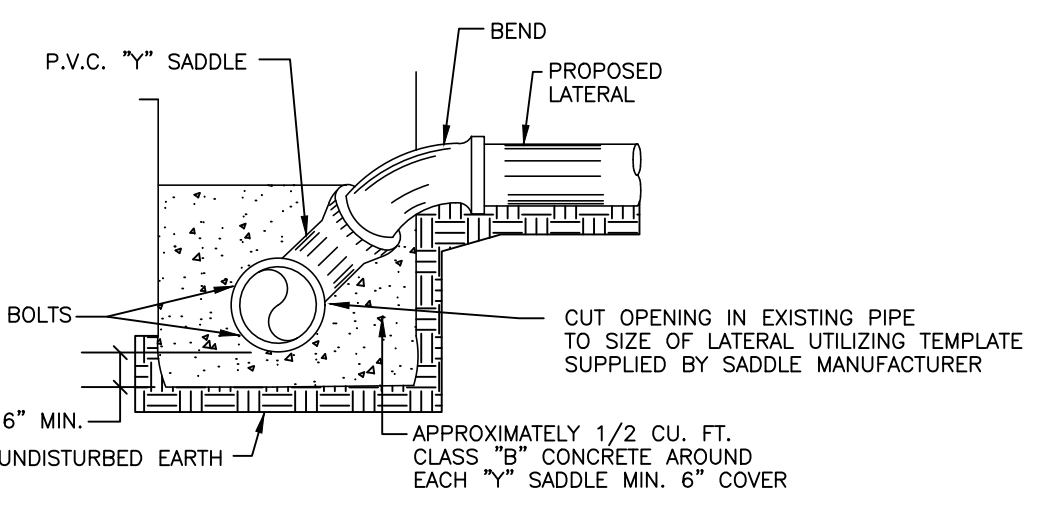

NOTE: SERVICE BEND AND Y BRANCH SHALL BE EITHER 4\"/>

\"Y\" SADDLE CONNECTION

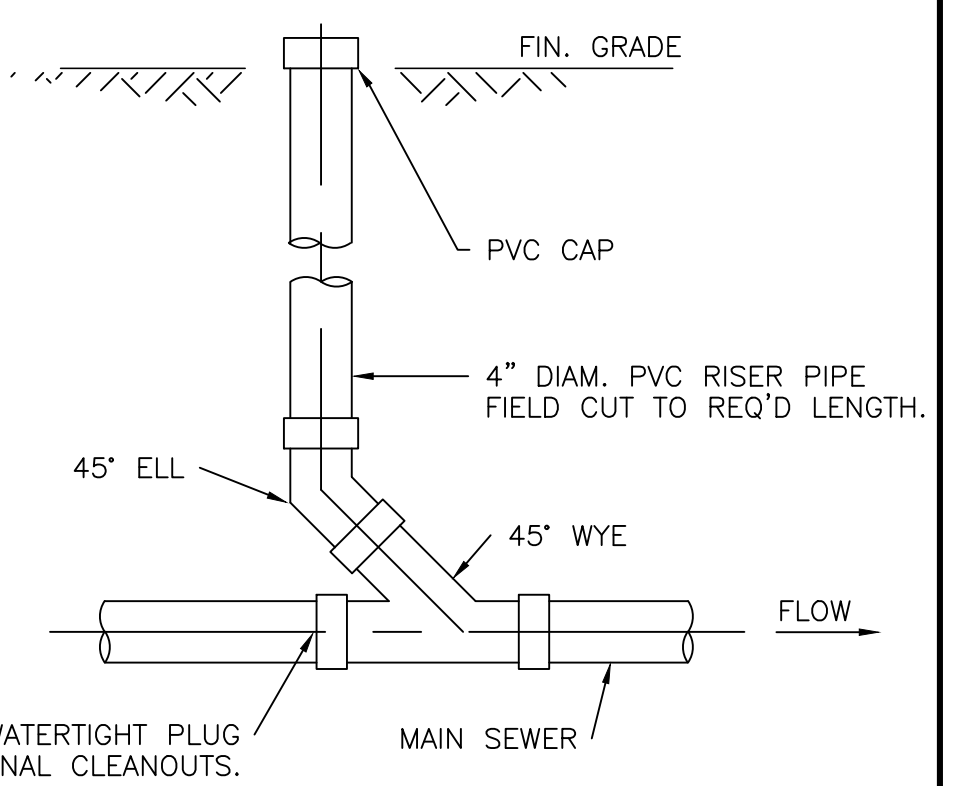

CLEANOUT DETAIL

NOT TO SCALE

The information shown on this plan is the result of a professional service rendered by G.D. Houtman & Son, Inc., reproduction of this plan without approval of G.D. Houtman & Son, Inc. is not permitted. The reproduction of a copy of this plan for the purpose of creating additional copies or retaining said plan shall, in no circumstance, be approved. Certification for the work contained herein is limited to the entity for whom the work was performed as of the date shown on the plans.

Note: All locations of existing utilities shown on the plan have been developed from existing utility records and / or above ground examination of the site. Completeness or accuracy of locations and depth of underground utilities or structures cannot be guaranteed. Contractor must verify location and depth of all underground utilities and facilities before start of work, as per PA Act 181 as per the latest amendment of PA Act 287 of 1974, Effective Mar. 28, 2007.

G. D. Houtman & Son, Inc. reserves its common law copyright and all other proprietary rights in these plans. All drawings, specifications and copies thereof are to remain property of G. D. Houtman & Son, Inc. They are to be used only in respect to this project. They are not to be assigned or represented to be suitable for reuse by owner or others on extensions of project or any other project. They are not to be assigned to any third party without first obtaining written permission by G.D. Houtman & Son, Inc. Any re-use without written permission for the specific purpose intended will be at the third party's sole risk and without liability or legal exposure to G. D. Houtman & Son, Inc. The third party shall further indemnify and hold harmless G. D. Houtman & Son, Inc. from all claims, damages, losses and expenses arising thereto or resulting therefrom.

These plans were prepared to obtain Subdivision/Land Development approval from the governing Municipality and to obtain certain permits from state and federal agencies. If a surveyor or engineer other than G. D. Houtman & Son, Inc. is contracted to perform construction stake-out services, said surveyor or engineer shall assume the responsibility for verifying dimensions, elevations, presence of underground utilities, utility interference, building size, etc. for coordinating information shown on lay-out plans, grading plans, utility plans, profiles, and details and for coordinating these plans with plans prepared by others such as utility companies, architectural building plans, landscape plans, lighting plans and etc.

| | | | | |
|--|----------|-----------------------------------|---|--|
| DATE | REVISION | SCALE | CONSTRUCTION DETAILS PLAN OF PROPERTY FOR CARAMANICO HOMES, LLC HAVERFORD TOWNSHIP DELAWARE COUNTY, PA | Sheet 6 of 6 PROJECT Caramanico WORK SHEET 39258 FILE 39258 |
| | | None DATE November 30, 2023 | | |
| G.D. HOUTMAN & SON, INC. CIVIL ENGINEERS-LAND SURVEYORS LAND PLANNERS 139 EAST BALMORE PIKE MEDIA, PA 19063 (610)585-4383 | | | GUSTAVE N. HOUTMANN PROFESSIONAL ENGINEER 50026-E PENN. STATE | |



TOWNSHIP OF
HAVERFORD

DELAWARE COUNTY
1014 DARBY ROAD
HAVERTOWN, PA 19083-2551
(610) 446-1000

LARRY HOLMES, ESQ, PRESIDENT
JUDY TROMBETTA, VICE PRESIDENT
DAVID R. BURMAN, TWP MANAGER/SECRETARY
AIMEE CUTHBERTSON, ASS'T TWP. MANAGER
JOHN R. WALKO ESQ., SOLICITOR
PENNONI ASSOCIATES, INC. ENGINEER

WARD COMMISSIONERS
1ST WARD BRIAN D. GONDEK
2ND WARD SHERYL FORSTE-GRUPP, PH.D
3RD WARD KEVIN MCCLOSKEY, ESQ
4TH WARD JUDY TROMBETTA
5TH WARD LAURA CAVENDER
6TH WARD LARRY HOLMES, ESQ
7TH WARD CONOR QUINN
8TH WARD GERARD T. HART, MD
9TH WARD WILLIAM F. WECHSLER

Manager 610-446-1000 ext. 2208
Human Resources 610-446-1000 ext. 2233

January 4, 2024

HAVTT 30251

Gary Smith, Zoning Officer
Haverford Township
1014 Darby Road
Havertown, PA 19083-2251

**RE: Minor Subdivision Plan
Caramanico Homes, LLC – 14 Claremont Boulevard**

Dear Mr. Smith:

As requested, we have reviewed the following prepared by G.D. Houtman & Son, Inc. in connection with the referenced property:

- *"Caramanico Homes, LLC"* (six sheets) dated November 30, 2023.
- *"Stormwater Management Calculations for Caramanico Homes, LLC, 14 Claremont Boulevard"* dated November 30, 2023.

The applicant, Caramanico Homes LLC, proposes to subdivide an existing 30,625 square foot lot (folio no. 22-09-00355-00) into three (3) new lots at the referenced property. A new single-family dwelling and driveway are proposed on each lot. Individual infiltration beds on each lot are proposed for stormwater management. The property is within the R-5 Residential Zoning District.

The applicant has requested the following waiver:

- From §160-4 requiring a two-step preliminary/final land development plan review process.

We offer the following comments:

ZONING

1. The applicant should confirm conformity of proposed setback lines with the median setback lines of existing structures on the same side of the street and within 300 feet of the proposed new construction. (§182-715)
2. A complete zoning compliance table showing proposed setbacks, impervious coverage, etc. shall be provided. (§160-4.E(5))
3. Two (2) parking spaces, measuring a minimum of 9 feet wide and 18 feet long, are required for each single-family dwelling (§182-707.B, §182-707.A(1)) The applicant should confirm that the required parking has been provided.

SUBDIVISION AND LAND DEVELOPMENT

4. The minimum right-of-way width for residential/minor collector streets is 50-feet. (160-5.B(3)[j](1)) The Township may require an additional 2.5 feet of right-of-way for the length of the property.
5. Signature blocks for the Township, Township Planning Commission and Township Engineer should be provided on the plan. (160-4.H(1)[e])
6. Permanent survey monuments located on the right-of-way lines at corners and at angle points are required to be indicated on the plan. (160-5.B(8))
7. In each residential district involving the creation of two (2) or more new building lots, land shall be required to be set aside for open space and/or parks and recreational facilities, or a fee-in-lieu requested. (160-5.C(2,4))

STORMWATER MANAGEMENT

8. A Drainage Plan Application and Checklist are required to be submitted. (§78-25.A.(6,7))
9. The proposed yard inlets should indicate a one (1) foot sump. (78-30.K)
10. All perimeter fence should be super silt fence.
11. Inlet protection should be provided for the proposed yard inlets. (78-25.B(20))
12. Proposed electric services should be indicated on the plan. (§78-25.B(5))
13. Topsoil stockpile locations should be indicated on the plan. (§78-25.B(20))
14. A BMP Maintenance Agreement shall be executed and a contribution of \$2,200.00 per lot to the Township Stormwater Control and BMP Operation and Maintenance Fund shall be made. (§78-49, §78-51)

GENERAL

15. A Sewage Facilities Planning module or exemption will be required. (§160-4.E(5[d]))
16. A foundation as-built plan will be required to confirm the proposed buildings are within the required building envelope.
17. The plans should indicate the location of the existing sanitary sewer lateral and whether it is to be re-used or abandoned.
18. The wye saddle detail shall be revised to reflect a cast iron saddle in lieu of PVC.
19. It appears portions of the existing stone wall along the southeast corner of the property are on the adjacent property. The applicant should indicate how the wall will be retained or reconstructed.
20. The sidewalk detail should be revised to indicate a minimum 3750 psi concrete. (Township Design Standards)
21. A curb opening detail indicating a minimum longitudinal length of depressed curb of 14 feet should be provided on the plan. (Township Design Standards)

22. A leveling area of not less than 20 feet in length and not greater than 4% in grade shall be provided at the end of the driveway at the street line for all driveways exceeding 6% in grade. (Township Design Standards)
23. A Township Road Opening Permit will be required for the driveway and utility installations.
24. Roadway restoration shall conform to the requirements §157-30 and the road restoration detail revised accordingly.
25. Tree protection fencing should be indicated for trees proposed to remain.
26. A tree removal permit is required for removal of the existing trees on site. (§170-4.B) All proposed landscaping and tree replacement should be reviewed by the Township Shade Tree Commission.

Should you have any further questions or comments, please contact the undersigned.

Sincerely,

PENNONI



Charles Faulkner, PE
Senior Engineer

CF/brg

cc: Caramanico Homes LLC
Gustave N. Houtmann, PE – G.D. Houtman & Son, Inc.



DELAWARE COUNTY PLANNING COMMISSION

2 W. Baltimore Avenue – Suite 202

Media, PA 19063

(610) 891-5200

Email: planning_department@co.delaware.pa.us

GINA BURRITT

DIRECTOR

Planning Department

January 19, 2024

Mr. David R. Burman
Haverford Township
1014 Darby Road
Havertown, PA 19083

RE: Name of Dev't: Caramanico Homes - 14 Claremont
DCPD File No.: 20-7936-24
Developer: Caramanico Homes
Location: East side of Claremont Blvd,
approximately 200' south of West Chester
Pike
Recv'd in DCPD: December 28, 2023

Dear Mr. Burman:

In accordance with the provisions of Section 502 of the Pennsylvania Municipalities Planning Code, the above described proposal has been sent to the Delaware County Planning Commission for review. At a meeting held on January 18, 2023, the Commission took action as shown in the recommendation of the attached review.

Please refer to the DCPD file number shown above in any future communications related to this application.

Very truly yours,

Gina Burritt
Director

cc: Caramanico Homes
G. D. Houtman and Son

2 W. Baltimore Avenue - 2nd Floor
Media, PA 19063
Phone: (610) 891-5200
Email: planning_department@co.delaware.pa.us

Date: January 19, 2024
File No.: 20-7936-24

PLAN TITLE: Caramanico Homes - 14 Claremont

DATE OF PLAN: November 30, 2023

OWNER OR AGENT: Caramanico Homes

LOCATION: East side of Claremont Blvd,
approximately 200' south of West
Chester Pike

MUNICIPALITY: Haverford Township

TYPE OF REVIEW: Final Subdivision and Land
Development

ZONING DISTRICT: R-5

SUBDIVISION ORDINANCE: Local

PROPOSAL: Subdivision: Subdivide 0.703 acre
into three lots

Land Development: Develop three
single-family detached dwellings

UTILITIES: Public

RECOMMENDATIONS: Approval, with consideration given
to staff comments

STAFF REVIEW BY: Michael A. Leventry

REMARKS:

CURRENT PROPOSAL

The plan proposes to subdivide one parcel into three and subsequently develop three single-family detached dwellings.



Date: January 19, 2024
File No.: 20-7936-24

REMARKS (continued):

SITE CHARACTERISTICS

The site fronts onto a local street and is currently undeveloped (a prior home and garage have been demolished).

APPLICABLE ZONING

The proposal is located within the R-5 district and is subject to applicable regulations set forth by the Municipal zoning code.

COMPLIANCE

The proposal appears to comply with the R-5 district provisions.

WAIVERS

The applicant is seeking the following waiver relief:

- Section 160-3E: To allow a combined preliminary/final plan submission.

Staff has no comment related to this waiver request.

HISTORICAL AND ARCHEOLOGICAL SIGNIFICANCE

The historically significant Fairview Acres at 14 Claremont Blvd. has already been demolished. It is on the 1994 Historic Resource Survey and should have been retained or documented prior to demolition. The Township should notify the Historical Commission of demolition permits for buildings such as this to avoid unnecessarily losing more of the Township's heritage.

The area of the house and the outbuildings has a high potential for underground resources and if any artifacts are found, the applicant should contact DCPD for a short documentation process.

Date: January 19, 2024
File No.: 20-7936-24

REMARKS (continued):

SEWAGE FACILITIES

The developer should contact the Pennsylvania Department of Environmental Protection regarding the need for sewage facilities planning approval.

The Municipality should confirm receipt of any necessary Pennsylvania Department of Environmental Protection planning approval prior to final approval.

STORMWATER MANAGEMENT

The Municipal Engineer must verify the adequacy of all proposed stormwater management facilities.

RECORDING

In accordance with Section 513(a) of the Pennsylvania Municipalities Planning Code (MPC), final plans must be recorded within ninety (90) days of municipal approval.

Resolution No. 2362-2024

American Rescue Plan Act
Coronavirus Local Fiscal Recovery Fund
Police Electric Vehicles

WHEREAS, Haverford Township's direct allocation from the Coronavirus State and Local Fiscal Recovery Fund was \$19.8 million;

WHEREAS, on April 1, 2022, the U.S. Department of Treasury released the Final Rule covering the Coronavirus State and Local Fiscal Recovery Fund, as created and directed by the American Rescue Plan Act authorizing recipients to use funds to invest in public health improvements, economic recovery and development, services to disproportionately affected communities, and general government services, among other allowable purposes; and,

WHEREAS, the Board of Commissioners desires to make improvements and financial investments in several Township projects and initiatives in accordance with the allowable spending structure as described by the U.S. Department of Treasury's Final Rule, as follows:

Purchase 2024 Landmaster AMP crew 4x4 electric ATV for a total funding allocation of \$23,699

Now, therefore, be it resolved, that the Board of Commissioners of Haverford Township hereby approves the use of funds from the Township's American Rescue Plan Fund allocation for the above referenced projects and initiatives.

Resolved this 12th day of February, 2024.

Township of Haverford
By:
C. Lawrence Holmes, Esq.
President

Attest:
David R. Burman
Township Manager/Secretary

Township of Haverford - Resolution No. 2363-2024

Request for Funding under the Commonwealth of Pennsylvania, Department of Community and Economic Development, COVID-19 ARPA Capital Projects Fund Multi-Purpose Community Facilities Program – Maker’s Space/Innovation Zone at Haverford Township Free Library Project.

Be it Resolved, that the Board of Commissioners of the Township of Haverford of Delaware County hereby acknowledges its support for an application to the Commonwealth of Pennsylvania, Department of Community and Economic Development, COVID-019 ARPA Capital Projects Fund Multi-Purpose Community Facilities Program in the amount of \$268,750 to assist with the construction and technology outfitting of the Maker’s Space/ Innovation Zone to be located within the newly renovated Haverford Township Free Library.

Be it Further Resolved, that the Applicant does hereby designate David R. Burman, Township Manager and Aimee M Cuthbertson, Assistant Township Manager as the officials to execute all documents and agreements between the Township of Haverford and the Department of Community and Economic Development to facilitate and assist in obtaining the requested grant.

Township of Haverford

By:

C. Lawrence Holmes, Esq.
President

Attest:

David R. Burman
Township Manager/Secretary

Township of Haverford - Resolution No. 2364-2024

Request for Funding under the Commonwealth of Pennsylvania, Department of Community and Economic Development, COVID-19 ARPA Capital Projects Fund Multi-Purpose Community Facilities Program – Haverford Township Skatium Project

Be it Resolved, that the Board of Commissioners of the Township of Haverford of Delaware County hereby acknowledges its support for an application to the Commonwealth of Pennsylvania, Department of Community and Economic Development, COVID-019 ARPA Capital Projects Fund Multi-Purpose Community Facilities Program in the amount of \$500,000 to assist with the space planning, construction and renovation of the locker rooms and related space at the Haverford Township Skatium.

Be it Further Resolved, that the Applicant does hereby designate David R. Burman, Township Manager and Aimee M Cuthbertson, Assistant Township Manager as the officials to execute all documents and agreements between the Township of Haverford and the Department of Community and Economic Development to facilitate and assist in obtaining the requested grant.

Township of Haverford

By:

C. Lawrence Holmes, Esq.
President

Attest:

David R. Burman
Township Manager/Secretary

Township of Haverford - Resolution No. 2365-2024

American Rescue Plan Act
Coronavirus Local Fiscal Recovery Fund
Public Works Heavy Equipment

Whereas, Haverford Township's direct allocation from the Coronavirus State and Local Fiscal Recovery Fund was \$19.8 million;

Whereas, on April 1, 2022, the U.S. Department of Treasury released the Final Rule covering the Coronavirus State and Local Fiscal Recovery Fund, as created and directed by the American Rescue Plan Act authorizing recipients to use funds to invest in public health improvements, economic recovery and development, services to disproportionately affected communities, and general government services, among other allowable purposes; and,

Whereas, the Board of Commissioners desires to make improvements and financial investments in several Township projects and initiatives in accordance with the allowable spending structure as described by the U.S. Department of Treasury's Final Rule, as follows:

One (1) 2024 F600 Chassis 4x4 SD Regular Cab 145" WB DRW XL (F6L) in an amount not to exceed \$63,335.00 under CoStars Contract #025-E22-381
Fred Beans Ford of Mechanicsburg 6320 Carlisle Pike Mechanicsburg, Pennsylvania 17050

For Chassis listed above:

One (1) Multi-Lift XR5S-3050 Hook Lift 12,000 Capacity

One (1) 10' Stainless Steel Dump Body

One (1) 20 Gallon Stainless Steel Valve/Tank Combo

One (1) Stainless Steel Salt Spreader with Poly Spinner

in an amount not to exceed \$89,500.00 under CoStars Contract #025-E22-432

Stephenson Equipment, INC. 4210 Chambers Hill Rd. Harrisburg, PA 17111

One (1) 11' Steel Flat Bed with Side Pockets Mounted in an amount not to exceed \$18,500.00 under CoStars Contract #025-E22-432
Stephenson Equipment, INC. 4210 Chambers Hill Rd. Harrisburg, PA 17111

One (1) Western 9' Pro Plus Snow Plow in an amount not to exceed \$8,000.00 under CoStars Contract# 025-E22-432
Stephenson Equipment, INC. 4210 Chambers Hill Rd. Harrisburg, PA 17111

One (1) 2-Ton Falcon Asphalt Recycler & Hot Box Hook Lift in an amount not to exceed \$40,911.20 under CoStars Contract# 025-E22-432
Stephenson Equipment, INC. 4210 Chambers Hill Rd. Harrisburg, PA 17111

One (1) 2024 Caterpillar 938 Front End Loader in an amount not to exceed \$281,165.00 under CoStars Contract #4400011420 Folly Cat INC. 855 Centennial Ave. Piscataway, NJ 08855

One (1) 2024 Broom Bear Sweeper on International Cab and Chassis in an amount not to exceed \$407,000.00 under CoStars Contract #025-E22-471 GranTurk Equipment Co., INC. 1 Schuylkill Parkway, Bldg. B, Bridgeport, PA 19405

One (1) 2024 Brush Bandit 18 Inch Tipper with Winch in an amount not to exceed \$98,715.00
under CoStars Contract #4400028339 SEI
Stephenson Equipment, INC. 4210 Chambers Hill Rd. Harrisburg, PA 17111

Three (3) SaltDogg Pro1500 Electric Poly Hopper Spreaders with Auger in an amount not to
exceed \$14,000.00 under CoStars Contract #4400028339
SEI Stephenson Equipment, INC. 4210 Chambers Hill Rd. Harrisburg, PA 17111

For a total fund obligation of \$1,008,937.00

Now, Therefore, be it Resolved, that the Board of Commissioners of Haverford Township
hereby approves the use of funds from the Township's American Rescue Plan Fund allocation
for the above referenced projects and initiatives.

Resolved this 12th day of February, 2024.

Township of Haverford

By:

C. Lawrence Holmes, Esq.

President

Attest:

David R. Burman

Township Manager/Secretary

Township of Haverford - Resolution No. 2366-2024

Whereas, the Township of Haverford is considering amendments to the General Laws of the Township of Haverford by amending Chapter 47 entitled "Amusement Devices" to further regulate the premises within which such devices may be permitted and associated definitions; amending Chapter 182 entitled "Zoning" to clarify the definition of Convenience Store, to define E-Liquids, Electronic Cigarettes, Electronic Nicotine Delivery Systems, Game of Skill Machines, Hookah Bars, Indoor Recreational or Amusement Facilities, Mechanical Amusement Devices, Significant Tobacco Retailers and Smoke Shops; to prohibit Mechanical Amusement Devices within the premises of Significant Tobacco Retailers and to prohibit Game of Skill Machines in Convenience Stores; to expressly prohibit Significant Tobacco Retailers in the C-2 Neighborhood Commercial District; to delete cigarette and tobacco as permitted to be sold in gift shops in the C-3 General Commercial District; to establish Significant Tobacco Retailers including Smoke Shops, Vape Shops and Hookah Lounges as a use permitted by Conditional Use in the C-5 Shopping Center Commercial District; and to establish the criteria for the approval of a Significant Tobacco Retailers use; and

Whereas, the Township desires to keep citizens and business interests informed as to the status of the proposed amendments.

Now, therefore it Resolved by the Board of Commissioners of the Township of Haverford, County of Delaware, Commonwealth of Pennsylvania that a public hearing shall be held before the Board of Commissioners on Monday, March 4, 2024 at 6:30 PM, in the Commissioners Meeting Room, Municipal Services Building, 1014 Darby Road, Havertown, Pennsylvania.

Resolved this 12th day of February, 2024.

Township of Haverford

By:
C. Lawrence Holmes, Esq.
President

Attest: David R. Burman
Township Manager
Township Manager/Secretary

Township of Haverford Police Department

Memorandum

Date: January 24, 2024

To: David R. Burman, Township Manager

From: John Viola

Re: New Vehicles

Whitmoyer Auto Group 1001 East Main Street Mount Joy, PA 17552
meets the requirements under COSTARS Contract #013-E22-264
for the purchase of the following Police vehicles:

Three, 2024 Chevrolet Tahoe Police vehicles CK10706
\$159,000

Two, 2024 Chevrolet Blazer Police vehicles, electric 1MF26
\$119,800

Total - \$278,800

Township of Haverford Police Department

Memorandum

Date: January 24, 2024

To: David R. Burman, Township Manager

From: John Viola

Re: New Vehicle

One (1) 2024 Landmaster AMP crew 4x4 electric ATV with a purchase price in the amount of \$22,800.01 from Wide World West Chester LLC 315, Westtown Road, West Chester PA 19382.

Township of Haverford - Public Works Department

Memorandum

Date: January 29, 2024

To: David R. Burman, Township Manager

From: Daniel Mariani, Director of Public Works

Re: Public Works Department Purchases

Description:

It is my recommendation that the Township enter into purchase agreements for the following pieces of heavy equipment in addition to specialty materials needed for the construction of a pole barn to provide additional storage at the public works yard. The funding for these purchases will come from the General Operating and Capital Project Budgets.

2024 F350 Regular Cab with 9ft Western Pro Plus Plow in the amount of \$66,110.00 under CoStars Contract #025-E22-387 from Hondru Ford, Manheim, PA

2024 F350 Super Cab with 9ft Western Pro Plus Plow in the amount of \$70,060.00 under CoStars Contract #025-E22-387 from Hondru Ford, Manheim, PA

2024 Altec 75ft Tree Bucket Truck with International Cab & Chassis in the amount of \$299,000.00 under CoStars Contract #4400019945 from Altec, Inc, Plains, PA

2024 HV607 International Cab & Chassis for Recycling Truck in the amount of \$128,164.40 under CoStars Contract #025-E22-471 from GranTurk Equipment Co. Inc, Bridgeport, PA

2024 20 yard Recycling Body for Cab & Chassis noted above in the amount of \$108,373.00 under CoStars Contract #025-E23-577 from Ascendence Trucks, Swedesboro, NJ

(1) Pole Barn with Concrete Pad in the amount of \$50,000.00 CoStars Contract #008-E23-1096 from Shirk Pole Buildings LLC, East Earl, PA

Township of Haverford - Public Works Department

Memorandum

Date: January 29, 2024

To: David R. Burman, Township Manager

From: Daniel Mariani, Director of Public Works

Re: Public Works Department Purchases

Description:

It is my recommendation that the Township enter into purchase agreements for the following vehicles and pieces of heavy equipment. The funding for these purchases will come from the Township's American Rescue Plan Fund.

One (1) 2024 F600 Chassis 4x4 SD Regular Cab 145" WB DRW XL (F6L in an amount not to exceed \$63,335.00 CoStars Contract #025-E22-381 Fred Beans Ford of Mechanicsburg 6320 Carlisle Pike Mechanicsburg, Pennsylvania 17050

One (1) Multi-Lift XR5S-3050 Hook Lift 12,000 Capacity
One (1) 10' Stainless Steel Dump Body
One (1) 20 Gallon Stainless Steel Valve/Tank Combo
One (1) Stainless Steel Salt Spreader with Poly Spinner in an amount not to exceed \$89,500.00 CoStars Contract #025-E22-432 Stephenson Equipment, INC. 4210 Chambers Hill Rd. Harrisburg, PA 17111

One (1) 11' Steel Flat Bed with Side Pockets Mounted in an amount not to exceed \$18,500.00 CoStars Contract #025-E22-432 Stephenson Equipment, INC. 4210 Chambers Hill Rd. Harrisburg, PA 17111

One (1) Western 9' Pro Plus Snow Plow in an amount not to exceed \$8,000.00 CoStars Contract #025-E22-432 Stephenson Equipment, INC. 4210 Chambers Hill Rd. Harrisburg, PA 17111

One (1) 2-Ton Falcon Asphalt Recycler & Hot Box Hook Lift in an amount not to exceed \$40,911.20 CoStars Contract#025-E22-432 Stephenson Equipment, INC. 4210 Chambers Hill Rd. Harrisburg, PA 17111

One (1) 2024 Caterpillar 938 Front End Loader in an amount not to exceed \$281,165.00 CoStars Contract #4400011420 Folly Cat INC. 855 Centennial Ave. Piscataway, NJ 08855

One (1) 2024 Broom Bear Sweeper on International Cab and Chassis in an amount not to exceed \$407,000.00 COSTAR #025-E22-471 GranTurk Equipment Co., INC. 1 Schuylkill Parkway, Bldg. B, Bridgeport, PA 19405

Township of Haverford - Public Works Department

Memorandum

Date: January 29, 2024

To: David R. Burman, Township Manager

From: Daniel Mariani, Director of Public Works

Re: Public Works Department Purchases

One (1) 2024 Brush Bandit 18 Inch Tipper with Winch in an amount not to exceed \$98,715.00
CoStars Contract # 025-E22-432 Stephenson Equipment, INC. 4210 Chambers Hill Rd.
Harrisburg, PA 17111

Three (3) SaltDogg Pro1500 Electric Poly Hopper Spreaders with Auger in an amount not
to exceed \$14,000.00 CoStars #025-E22-432 SEI Stephenson Equipment, INC. 4210
Chambers Hill Rd. Harrisburg, PA 17111

For a total fund obligation of \$1,008,937.00